

# POWER TRANSMISSION

**GEARBOXES  
CALIPER DISC BRAKES  
CLUTCHES**

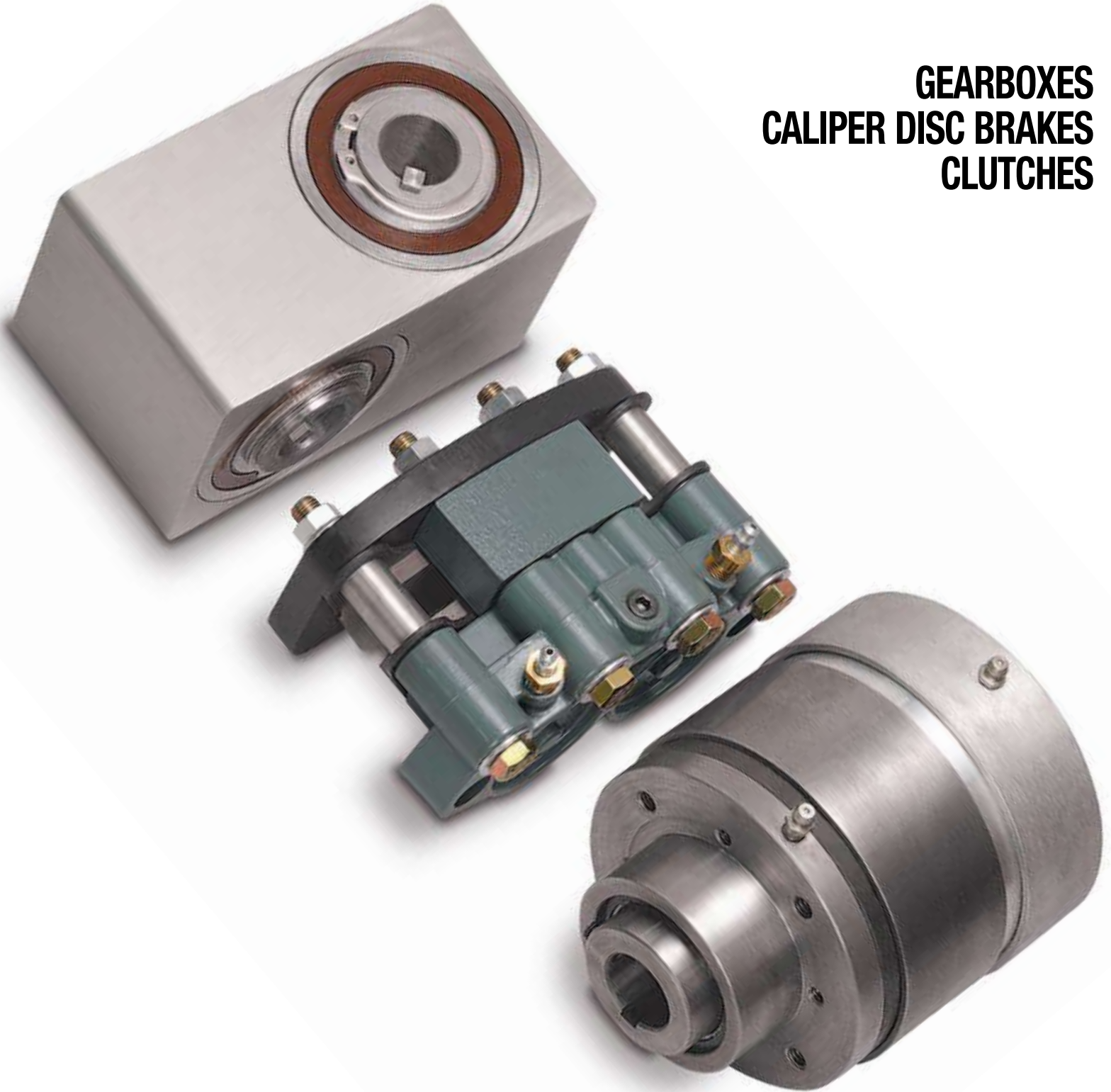

**OVER 50 YEARS OF PROVEN PERFORMANCE**

# TOLOMATIC HAS THE RESOURCES TO HELP YOU GET WHAT YOU NEED.

## PRODUCTS AND PEOPLE YOU NEED TO GET THE JOB DONE RIGHT.

At Tolomatic we have the resources and the experience to give you what you need when you need it. Working together we can find solutions whether it is a new feature, better performance or a whole new product line. Our sales department will make sure all your questions are answered. Our engineers will assist you with your application design. Our model shop will make all the tooling and specials you need for a new product—not in 6 months or a year—but when you need them.

## QUALITY PRODUCTS, COMPETITIVELY PRICED, WHEN YOU WANT THEM.

Our engineering laboratory pushes our products to the breaking point running them 24 hours a day, 7 days a week for millions of cycles looking for ways to improve them. They work with R&D to develop new manufacturing techniques and to perfect new products. For each new product, detailed engineered drawings are converted into hand-crafted sample products for testing, then precision tooling is built on site by Tolomatic's own skilled craftsmen with the highest standards of quality, care and dedication to details. The products are tested again by engineering and by selected field representatives. Tolomatic has heavily invested in research to guarantee you delivery of the highest quality products not in months or weeks, but within days of your order, and with a warranty rate less than 1/2 of 1%.

## UNCONDITIONAL 100% SATISFACTION GUARANTEE.

Tolomatic has built its reputation on customer satisfaction. For over 50 years it has been our policy that, if for any reason you have a problem with any Tolomatic product ordered, we will do whatever it takes to make sure you are 100% satisfied. Working together we will arrive at a solution that works best for you.

## TOLOMATIC TRAINING CENTER

There is a Tolomatic product for just about every application that may come your way and it is our goal to remove every obstacle, give you every tool, device and piece of knowledge necessary to learn how to size and apply Tolomatic products. That is why we supply the most advanced in-depth training in the industry— free of charge to all our distributors and their customers.



*Located in west suburban Minneapolis, Minnesota, Tolomatic headquarters (a 100,000 sq. ft. state-of-the-art facility) is designed for improved communication and manufacturing techniques to meet customer needs today and well into the future.*

© Copyright 2009, Tolomatic, Inc. All rights reserved. No part of this publication may be reproduced, transmitted, transcribed, stored in a retrieval system, or translated into any language in any form by any means without the written permission of Tolomatic, Inc.

Tolomatic, Axidyne, and Excellence in Motion are registered trademarks, Tolomatic, Inc. Other product and corporate names may be trademarks of other companies, and are used only for explanation and to the owner's benefit, without intent to infringe.

Information furnished in this catalog is believed to be accurate and reliable. However, Tolomatic assumes no responsibility for its use or for any errors that may appear in this document. Tolomatic reserves the right to change the design or operation of the equipment described herein and any associated motion products without notice. Information in this document is subject to change without notice.

200810171150 • 5M

# Contents

## INTRODUCTION

DEDICATED TO YOUR SATISFACTION . . . ii	WORLD CLASS PRODUCTS . . . . . iii	TOLOMATIC ON THE INTERNET . . . . . iv
---	------------------------------------	--

## RIGHT ANGLE GEARBOXES

SLIDE-RITE GEARBOX . . . . . 2	3:2 Ratio; US . . . . . 6	3:2 Ratio; US & Metric . . . . . 14
ENDURANCE TECHNOLOGY . . . . . 2	2:1 Ratio; US . . . . . 7	2:1 Ratio; US & Metric . . . . . 19
APPLICATION EXAMPLE . . . . . 3	FLOAT-A-SHAFT . . . . . 8	2.5:1 Ratio; US . . . . . 22
COMPACT SERIES . . . . . 4	APPLICATIONS . . . . . 8	Float-A-Shaft & Slide-Rite Gearbox
1:1 Ratio; US & Metric . . . . . 4	INTRODUCTION . . . . . 9	Selection . . . . . 23
1:1 Ratio; CR-US . . . . . 4	COMPACT SERIES . . . . . 10	Installation . . . . . 24
STANDARD SERIES . . . . . 5	1:1 Ratio; US & Metric . . . . . 10	Shaft & Keyway Requirements . . . . . 24
1:1 Ratio; US & Metric . . . . . 5	STANDARD SERIES . . . . . 13	
1:1 Ratio; CR-US . . . . . 5	1:1 Ratio; US & Metric . . . . . 13	

## CALIPER DISC BRAKES

FEATURES . . . . . 26	COMBOS . . . . . 50	FS595 DUAL . . . . . 78
APPLICATIONS . . . . . 28	H/ME20 . . . . . 50	DISCS HUBS & BUSHINGS . . . . . 80
SELECTION GRAPHS . . . . . 29	H/ME220 . . . . . 54	Hub & Disc Assemblies . . . . . 80
PNEUMATIC BRAKES . . . . . 32	MECHANICAL BRAKES . . . . . 56	Fixed Hub & Disc . . . . . 80
P10 . . . . . 32	ME10 . . . . . 56	Hub & Disc with QD
P20 . . . . . 34	ME20 . . . . . 59	Bushings . . . . . 82
P220 . . . . . 36	ME220 . . . . . 62	QD Bushings . . . . . 86
HYDRAULIC BRAKES . . . . . 38	MB3 . . . . . 64	One Piece Hub & Disc /
H10 . . . . . 38	SPRING APPLIED BRAKES . . . . . 66	Blank Disc . . . . . 86
H20 . . . . . 40	FS20 . . . . . 66	Disc With Pilot Hole /
H220 . . . . . 42	FS220B . . . . . 68	Intensifier . . . . . 87
H220I . . . . . 44	FS220C . . . . . 70	Tension Control Combinations . . . . . 88
H441 . . . . . 46	FS220BI . . . . . 72	CALIPER DISC BRAKE SELECTION . . . . . 89
H960 . . . . . 48	FS220CI . . . . . 74	APPLICATION DATA WORKSHEET . . . . . 96
HYDRAULIC/MECHANICAL BRAKE	FS595 . . . . . 76	

## DISC CONE CLUTCHES

APPLICATIONS . . . . . 97	FEATURES . . . . . 99	1209-1309C SERIES . . . . . 104
SELECTION GRAPHS . . . . . 98	1207-1307D SERIES . . . . . 100	Optional Combinations . . . . . 106
DISC CONE CLUTCH . . . . . 99	1208-1308D SERIES . . . . . 102	DISC CONE CLUTCH SELECTION . . . . . 108

## ENGINEERING RESOURCES

GLOSSARY . . . . . 110	CONVERSION TABLES . . . . . 111	TERMS / CONDITIONS OF SALE . . . . . 113
------------------------	---------------------------------	--

# The Tolomatic Difference

Over 50 Years of Proven Performance

## EXCELLENT TECHNICAL SUPPORT



### OUR PEOPLE MAKE THE DIFFERENCE!

Expect prompt, courteous replies to all of your application and product questions.

## INDUSTRY LEADING DELIVERIES



**STANDARD CATALOG PRODUCTS SHIP IN FIVE WORKING DAYS OR LESS** - same day for many items. Modified and custom products ship weeks ahead of the competition. Every product is built with **ENDURANCE TECHNOLOGY** components and quality tested before shipment.

## CONVENIENT ORDERING



[www.tolomatic.com](http://www.tolomatic.com) - Be assured of speedy service, quality products and great pricing, all at your convenience.



# The Tolomatic Difference

Over 50 Years of Proven Performance

## CREATIVE SOLUTIONS...ENGINEERED DAILY

### STANDARD PRODUCTS



*ISO 9001 quality procedures combined with **ENDURANCE TECHNOLOGY** for trouble-free installation and start-up.*

- Over 35 distinct product lines detailed in over 4,000 web pages.
- User specified stroke length is standard.

### MODIFIED PRODUCTS



*Modified products, like this spring applied brake with modified pressure chamber for low pressure release, extend the range of environments and applications where Tolomatic products can be used.*

- Modifications include user specified tapped holes, materials, lubricants, coatings, and/or mounting brackets.

### CUSTOM PRODUCTS

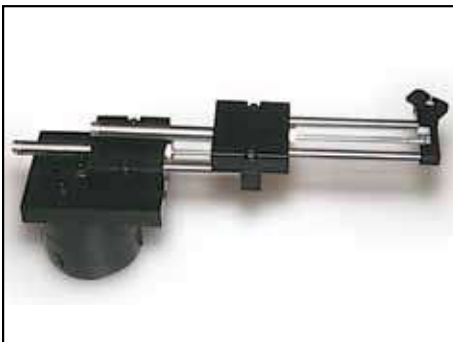

*Challenges like this multi-axis actuator built to fit a manufacturer's motion, space and accuracy requirements are a regular part of our daily activities.*

- Custom solutions for unique motion requirements.
- We will work with you to design a motion product within your space, budget, and time requirements.

# The Tolomatic Difference

A USEFUL WEB SITE: [www.tolomatic.com](http://www.tolomatic.com)

## COMPLETE INFORMATION AVAILABLE ONLINE

PRODUCT SUPPORT AVAILABLE 24/7 AT [www.tolomatic.com](http://www.tolomatic.com)

Our web site is your definitive source for EVERYTHING you need to know about Tolomatic and our products.

Check the home page for news and featured products

Check here for similar products

Search tool gets the information you need - fast!

Easy access to sizing software

2D drawings and 3D models available on the web

- Available in many popular formats

Similar to Windows Explorer®, this handy navigation is always available

**Power Transmission - Hydraulic Caliper Disc Brakes - Mounting Dimensions**

**H220: Mounting Dimensions**

Disc Diameter	6.313"	8"	10"	12"	16"
Braking Radius E	2.38"	3.15"	4.11"	5.08"	7.21"
F	2.13"	3.00"	4.00"	5.00"	7.09"
G	3.07"	3.94"	4.94"	5.94"	8.03"
H	3.45"	4.32"	5.32"	6.32"	8.41"
J	4.30"	5.17"	6.17"	7.17"	9.26"



## **SLIDE-RITE™ GEARBOX and SLIDE-RITE™CR GEARBOX**

Pages 2 through 7



## **FLOAT-A-SHAFT (FAS) GEARBOX**

Pages 8 through 24

Visit [www.tolomatic.com](http://www.tolomatic.com) for the latest updates, CAD files and ordering.

# Slide-Rite® & Slide-Rite®CR Gearbox

## COMPACT SIZE & STANDARD SIZE

SLIDE-RITE  
GEARBOXENDURANCE  
TECHNOLOGYAPPLICATION  
EXAMPLECOMPACT  
SERIES  
1:1 RATIOSTANDARD  
SERIES  
1:1 RATIOSTANDARD  
SERIES  
3:2 RATIOSTANDARD  
SERIES  
2:1 RATIOFLOAT-A-  
SHAFT

APPLICATIONS

INTRODUCTION

COMPACT  
SERIES  
1:1 RATIOSTANDARD  
SERIES  
1:1 RATIOSTANDARD  
SERIES  
3:2 RATIOSTANDARD  
SERIES  
2:1 RATIOSTANDARD  
SERIES  
2.5:1 RATIO

SELECTION

INSTALLATION

SHAFT &  
KEYWAY  
REQUIREMENTS

The **Slide-Rite®**, like the classic **Float-A-Shaft®**, is a universal right angle gearbox. It consists of two 45° helical gears that mesh at right angles, designed to turn power at 90°. It can be operated in either direction and can slide axially along the drive or driven shaft.

The **Slide-Rite®** gearbox's unique floating design maintains perfect shaft alignment allowing for easy installation.

A solid one-piece aluminum housing seals the gears from outside contaminants, providing for smooth operation in even the harshest industrial environments.

### ENDURANCE TECHNOLOGY<sup>SM</sup>

Look for this endurance technology symbol indicating our durability design features

#### LEAK-PROOF PERFORMANCE

- One-piece housing, one-piece geared shaft and sealed bearings offer leak-proof performance and excellent service life

#### PRELUBRICATED

- Prelubricated for long, trouble-free service

#### ONE-PIECE GEARED SHAFT

- Fewer parts to wear out

#### USES STANDARD TRANSMISSION SHAFTING

#### HARD COATED ALUMINUM CASE

- Resists corrosion and forms its own lubricant reservoir

#### THREADED MOUNTING HOLES

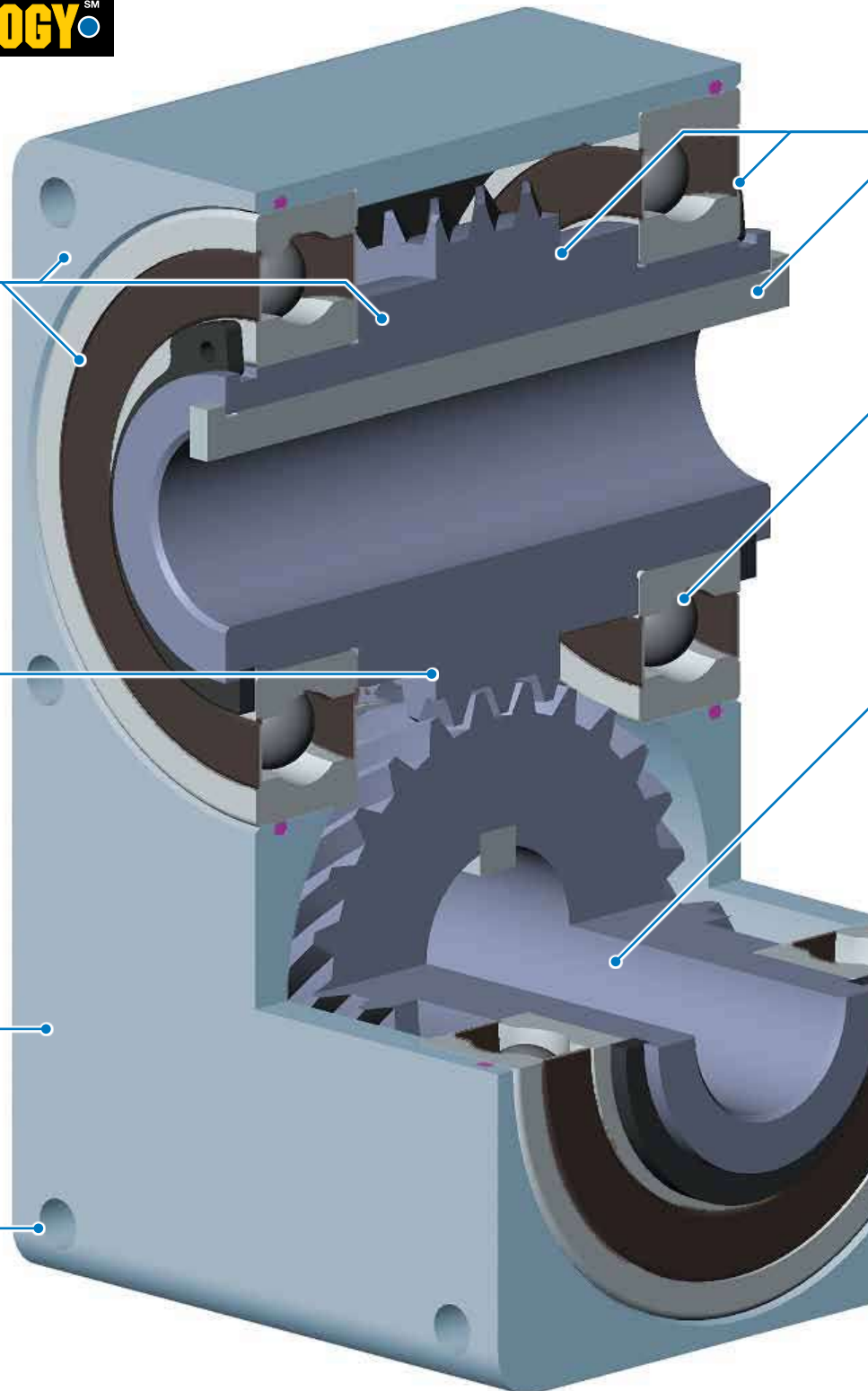



## APPLICATION EXAMPLE

The specially selected corrosion resistant components of the **Slide-Rite®CR** Gearbox make it the perfect choice for environmentally challenging applications.

### SLIDE-RITE®CR FEATURES:

#### • HELICAL GEARS, KEYS, RETAINING RINGS •

##### • ALLOY STEEL •

- 45 degree helical gears are hardened alloy steel
- High performance, long life construction

##### • NICKEL PLATED •

- Corrosion resistant electroless nickel-plated geared sleeves, keys and retaining rings

#### • BEARINGS AND BEARING RACES •

##### • HARDENED STEEL •

- High performance, long life materials

##### • STAINLESS STEEL •

- Corrosion resistant stainless steel balls and races

#### • PRECISION GROUND BORES •

##### • SPECIFICATIONS •

- Max speed: 1,200 RPM
- Backlash: < 1 degree
- Bidirectional
- Slide through bore: limited only by length of keyway on shaft

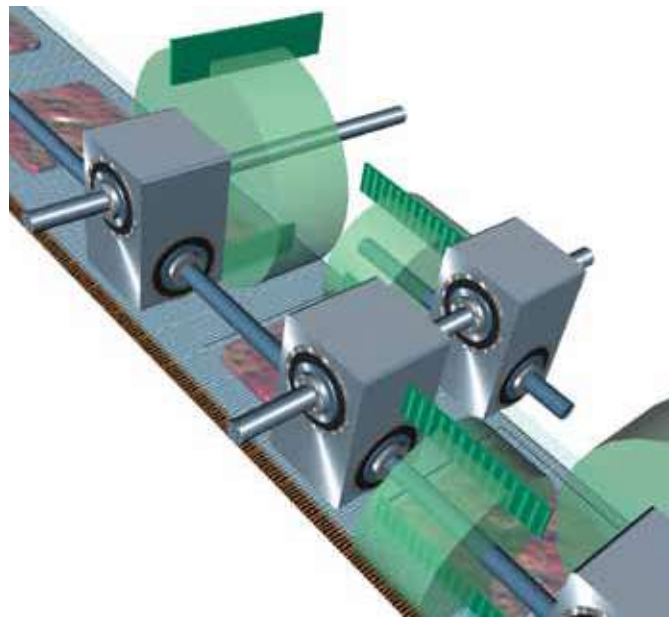

#### **Application Description:**

A manufacturer of frozen pizzas needed a way to cut and seal the plastic packaging for multiple sizes of their signature square pizza.

#### **Application Requirements:**

- Output of 60 pizzas per minute
- 4" adjustment range
- No maintenance - washdown environment

#### **Tolomatic Solution: Slide-Rite®CR Gearboxes**

The sealed, high speed, corrosion resistant design of the Slide-Rite®CR provides the high throughput necessary in this application. Other important application design features: Using multiple right angle gearboxes, a single motor, located outside the wash down area, synchronously drives both cutting and sealing units. The slide through bore feature of the Slide-Rite® offers adjustability for several pizza sizes.

Specifications and endurance technology features apply to all sizes of Slide-Rite® gearboxes.

## COMPACT SIZE – 1:1 RATIO – U.S. & METRIC

### AVAILABLE STYLES

1:1 US STANDARD  
1:1 METRIC

1:1 SLIDE-RITE®CR; US STANDARD



### DIMENSIONS

Model Builder 3D CAD Available at: [www.tolomatic.com](http://www.tolomatic.com)

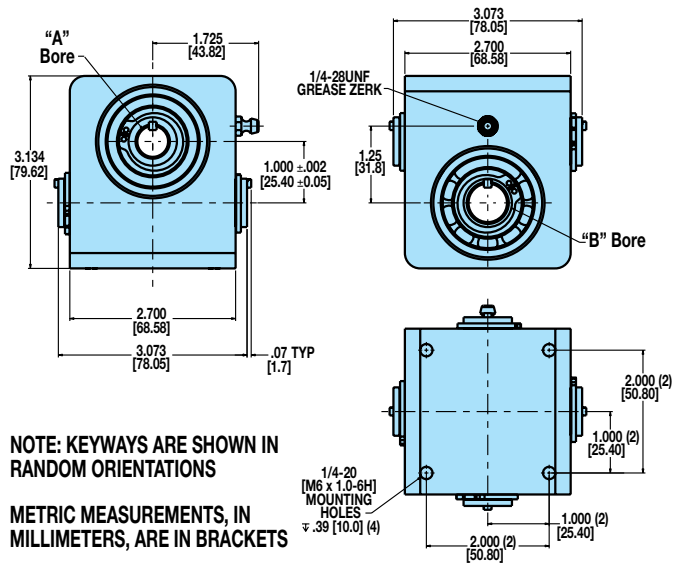

### PERFORMANCE DATA

#### High Torque Ball Bearings

#### Torque and Efficiency vs RPM at Maximum Operating Temperature

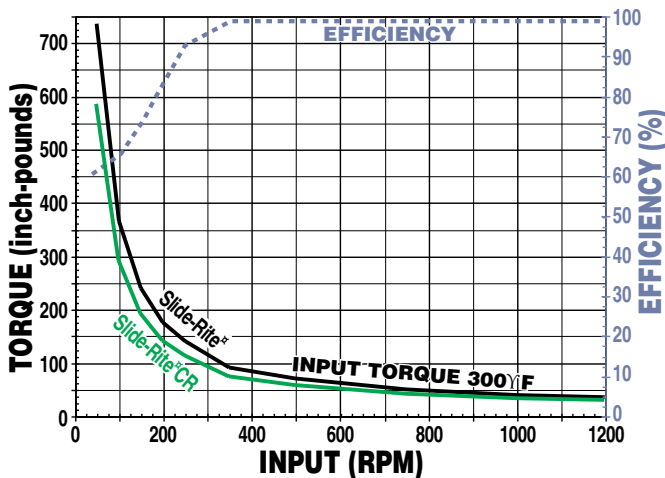

#### Models and Bore Dimensions

#### COMPACT SIZE – 1:1 RATIO – U.S. HIGH TORQUE BALL BEARING

SLIDE-RITE® MODEL NUMBER	SLIDE-RITE®CR MODEL NUMBER	RH or LH	"A" BORE		"B" BORE		APPROX. WEIGHT (LBS.)
			BORE SIZE (IN.)	WxD KEYWAY (IN.)	BORE SIZE (IN.)	WxD KEYWAY (IN.)	
0120-0400	0120-0420	RH	1/2	1/8 x 1/16	1/2	1/8 x 1/16	2.7
0121-0400	0121-0420	LH	1/2	1/8 x 1/16	1/2	1/8 x 1/16	2.7
0122-0400	0122-0420	RH	1/2	1/8 x 1/16	5/8	1/8 x 1/16	2.6
0123-0400	0123-0420	LH	1/2	1/8 x 1/16	5/8	1/8 x 1/16	2.6
0124-0400	0124-0420	RH	5/8	1/8 x 1/16	5/8	1/8 x 1/16	2.5
0125-0400	0125-0420	LH	5/8	1/8 x 1/16	5/8	1/8 x 1/16	2.5

#### COMPACT SIZE – 1:1 RATIO – METRIC HIGH TORQUE BALL BEARING

MODEL NUMBER	RH or LH	"A" BORE		"B" BORE		APPROX. WEIGHT (kg.)
		BORE SIZE (mm)	WxD KEYWAY (mm)	BORE SIZE (mm)	WxD KEYWAY (mm)	
0120-0410	RH	12	4 x 2	12	4 x 2	1.2
0121-0410	LH	12	4 x 2	12	4 x 2	1.2
0122-0410	RH	12	4 x 2	15	5 x 2.5	1.2
0123-0410	LH	12	4 x 2	15	5 x 2.5	1.2
0124-0410	RH	15	5 x 2.5	15	5 x 2.5	1.1
0125-0410	LH	15	5 x 2.5	15	5 x 2.5	1.1

# Slide-Rite® & Slide-Rite®CR Gearbox

## STANDARD SIZE – 1:1 RATIO – U.S. & METRIC

### AVAILABLE STYLES

1:1 US STANDARD  
1:1 METRIC



1:1 SLIDE-RITE®CR; US STANDARD



### PERFORMANCE DATA

**High Torque Ball Bearings**  
**Torque and Efficiency vs RPM**  
**at Maximum Operating Temperature**

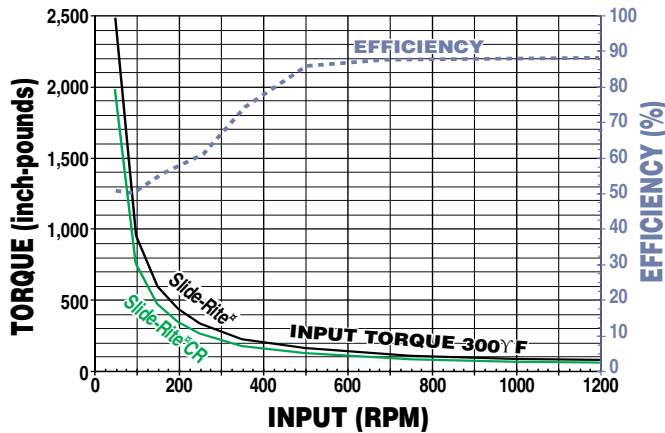

### Models and Bore Dimensions

**STANDARD SIZE – 1:1 RATIO – U.S.**  
**HIGH TORQUE BALL BEARING**

SLIDE-RITE® MODEL NUMBER	SLIDE-RITE®CR MODEL NUMBER	RH or LH	"A" BORE			"B" BORE			APPROX. WEIGHT (LBS.)
			BORE SIZE (IN.)	WxD (IN.)	"C" KEYWAY DIM. (IN.)	BORE SIZE (IN.)	WxD (IN.)	"D" KEYWAY DIM. (IN.)	
0220-0400	0220-0420	RH	3/4	3/16 x 3/32	.10	3/4	3/16 x 3/32	.10	10.7
0221-0400	0221-0420	LH	3/4	3/16 x 3/32	.10	3/4	3/16 x 3/32	.10	10.7
0222-0400	0222-0420	RH	3/4	3/16 x 3/32	.10	1	1/4 x 1/8	.13	10.4
0223-0400	0223-0420	LH	3/4	3/16 x 3/32	.10	1	1/4 x 1/8	.13	10.4
0224-0400	0224-0420	RH	3/4	3/16 x 3/32	.10	1-1/4	1/4 x 1/8	.13	9.9
0225-0400	0225-0420	LH	3/4	3/16 x 3/32	.10	1-1/4	1/4 x 1/8	.13	9.9
0226-0400	0226-0420	RH	1	1/4 x 1/8	.13	1	1/4 x 1/8	.13	10.0
0227-0400	0227-0420	LH	1	1/4 x 1/8	.13	1	1/4 x 1/8	.13	10.0
0228-0400	0228-0420	RH	1	1/4 x 1/8	.13	1-1/4	1/4 x 1/8	.13	9.6
0229-0400	0229-0420	LH	1	1/4 x 1/8	.13	1-1/4	1/4 x 1/8	.13	9.6
0230-0400	0230-0420	RH	1-1/4	1/4 x 1/8	.13	1-1/4	1/4 x 1/8	.13	9.1
0231-0400	0231-0420	LH	1-1/4	1/4 x 1/8	.13	1-1/4	1/4 x 1/8	.13	9.1

### DIMENSIONS

Model Builder 3D CAD Available at: [www.tolomatic.com](http://www.tolomatic.com)

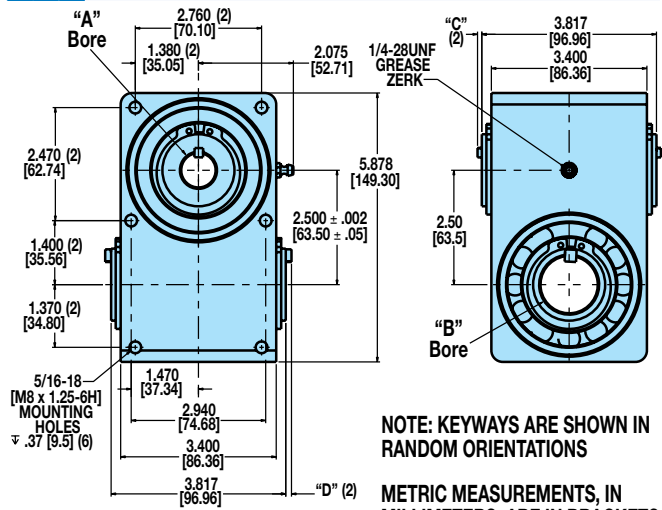

**STANDARD SIZE – 1:1 RATIO – METRIC**  
**HIGH TORQUE BALL BEARING**

MODEL NUMBER	RH or LH	"A" BORE			"B" BORE			APPROX. WEIGHT (kg.)
		BORE SIZE (mm)	WxD (mm)	"C" KEYWAY DIM. (mm)	BORE SIZE (mm)	WxD (mm)	"D" KEYWAY DIM. (mm)	
0220-0410	RH	20	6 x 3	3.2	20	6 x 3	3.2	4.8
0221-0410	LH	20	6 x 3	3.2	20	6 x 3	3.2	4.8
0222-0410	RH	20	6 x 3	3.2	25	8 x 3.5	3.2	4.7
0223-0410	LH	20	6 x 3	3.2	25	8 x 3.5	3.2	4.7
0224-0410	RH	20	6 x 3	3.2	30	8 x 3.5	3.2	4.5
0225-0410	LH	20	6 x 3	3.2	30	8 x 3.5	3.2	4.5
0226-0410	RH	25	8 x 3.5	3.2	25	8 x 3.5	3.2	4.5
0227-0410	LH	25	8 x 3.5	3.2	25	8 x 3.5	3.2	4.5
0228-0410	RH	25	8 x 3.5	3.2	30	8 x 3.5	3.2	4.4
0229-0410	LH	25	8 x 3.5	3.2	30	8 x 3.5	3.2	4.4
0230-0410	RH	30	8 x 3.5	3.2	30	8 x 3.5	3.2	4.2
0231-0410	LH	30	8 x 3.5	3.2	30	8 x 3.5	3.2	4.2

GEARBOXES

SLIDE-RITE  
GEARBOX

ENDURANCE  
TECHNOLOGY

APPLICATION  
EXAMPLE

COMPACT  
SERIES  
1:1 RATIO

STANDARD  
SERIES  
1:1 RATIO

STANDARD  
SERIES  
3:2 RATIO

STANDARD  
SERIES  
2:1 RATIO

FLOAT-A-  
SHAFT

APPLICATIONS

INTRODUCTION

COMPACT  
SERIES  
1:1 RATIO

STANDARD  
SERIES  
1:1 RATIO

STANDARD  
SERIES  
3:2 RATIO

STANDARD  
SERIES  
2:1 RATIO

STANDARD  
SERIES  
2.5:1 RATIO

SELECTION

INSTALLATION

SHAFT &  
KEYWAY  
REQUIREMENTS

## STANDARD SIZE – 3:2 RATIO – U.S.

SLIDE-RITE GEARBOX

ENDURANCE TECHNOLOGY

APPLICATION EXAMPLE

COMPACT SERIES 1:1 RATIO

STANDARD SERIES 1:1 RATIO

STANDARD SERIES 3:2 RATIO

STANDARD SERIES 2:1 RATIO

FLOAT-A-SHAFT

APPLICATIONS

INTRODUCTION

COMPACT SERIES 1:1 RATIO

STANDARD SERIES 1:1 RATIO

STANDARD SERIES 3:2 RATIO

STANDARD SERIES 2:1 RATIO

STANDARD SERIES 2.5:1 RATIO

SELECTION

INSTALLATION

SHAFT & KEYWAY REQUIREMENTS

### AVAILABLE STYLES

3:2 US STANDARD



### DIMENSIONS

Model Builder 3D CAD Available at: [www.tolomatic.com](http://www.tolomatic.com)

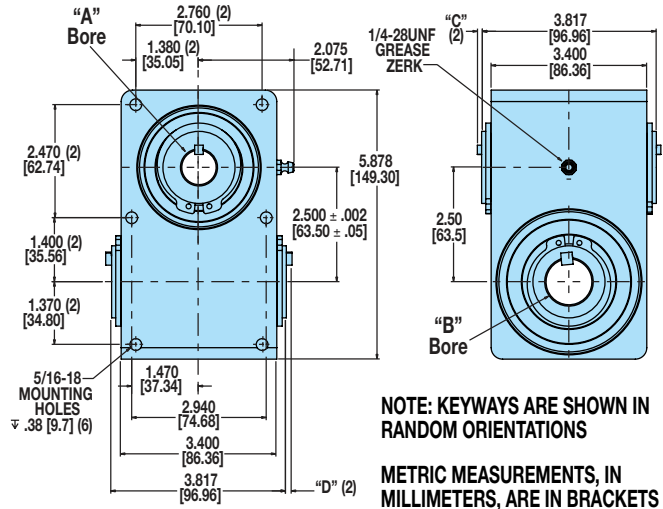

### PERFORMANCE DATA

#### High Torque Ball Bearings

#### Torque and Efficiency vs RPM at Maximum Operating Temperature

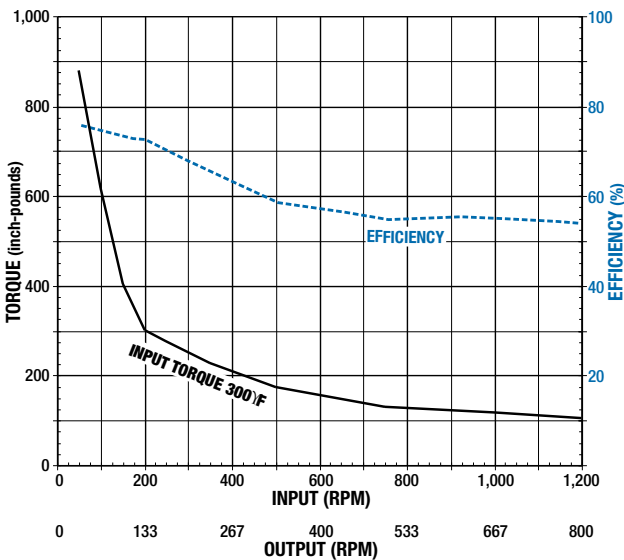

#### Models and Bore Dimensions

#### STANDARD SIZE – 3:2 RATIO – U.S. HIGH TORQUE BALL BEARING

MODEL NUMBER	RH or LH	"A" BORE			"B" BORE			APPROX. WEIGHT (LBS.)
		BORE SIZE (IN.)	WxD (IN.)	"C" DIM. (IN.)	BORE SIZE (IN.)	WxD (IN.)	"D" DIM. (IN.)	
0320-0460	RH	3/4	3/16 x 3/32	.10	3/4	3/16 x 3/32	.10	10.3
0321-0460	LH	3/4	3/16 x 3/32	.10	3/4	3/16 x 3/32	.10	10.3
0322-0460	RH	3/4	3/16 x 3/32	.10	1	1/4 x 1/8	.13	10.0
0323-0460	LH	3/4	3/16 x 3/32	.10	1	1/4 x 1/8	.13	10.0
0324-0460	RH	3/4	3/16 x 3/32	.10	1-1/4	1/4 x 1/8	.13	9.5
0325-0460	LH	3/4	3/16 x 3/32	.10	1-1/4	1/4 x 1/8	.13	9.5
0326-0460	RH	1	1/4 x 1/8	.13	1	1/4 x 1/8	.13	9.6
0327-0460	LH	1	1/4 x 1/8	.13	1	1/4 x 1/8	.13	9.6
0328-0460	RH	1	1/4 x 1/8	.13	1-1/4	1/4 x 1/8	.13	9.1
0329-0460	LH	1	1/4 x 1/8	.13	1-1/4	1/4 x 1/8	.13	9.1
0330-0460	RH	1-1/4	1/4 x 1/8	.13	1-1/4	1/4 x 1/8	.13	8.7
0331-0460	LH	1-1/4	1/4 x 1/8	.13	1-1/4	1/4 x 1/8	.13	8.7



## STANDARD SIZE – 2:1 RATIO – U.S.

### AVAILABLE STYLES

2:1 US STANDARD



### DIMENSIONS

Model Builder 3D CAD Available at: [www.tolomatic.com](http://www.tolomatic.com)

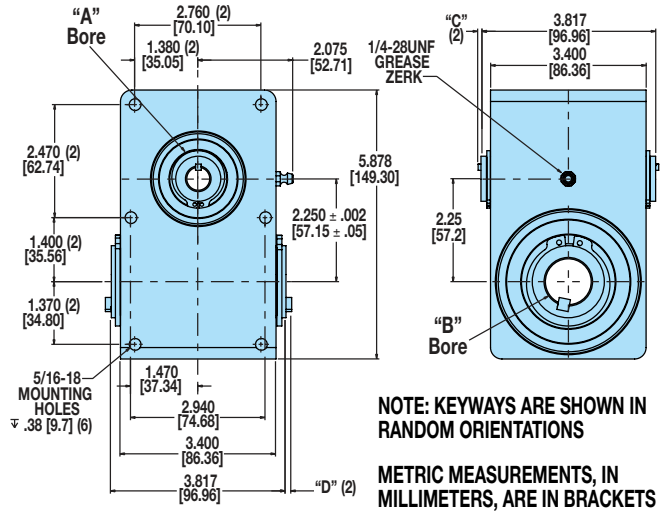

### PERFORMANCE DATA

#### High Torque Ball Bearings

#### Torque and Efficiency vs RPM at Maximum Operating Temperature

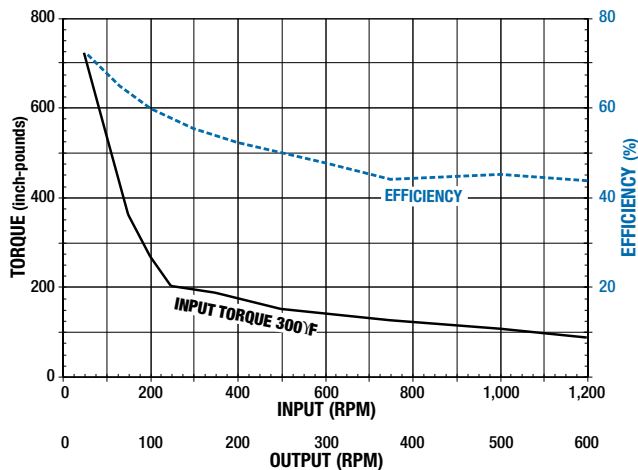

#### Models and Bore Dimensions

#### STANDARD SIZE – 2:1 RATIO – U.S. HIGH TORQUE BALL BEARING

MODEL NUMBER	RH or LH	"A" BORE			"B" BORE			APPROX. WEIGHT (LBS.)
		BORE SIZE (IN.)	WxD (IN.)	"C" DIM. (IN.)	BORE SIZE (IN.)	WxD (IN.)	"D" DIM. (IN.)	
0220-0460	RH	1/2	1/8 x 1/16	.07	3/4	3/16 x 3/32	.10	10.7
0221-0460	LH	1/2	1/8 x 1/16	.07	3/4	3/16 x 3/32	.10	10.7
0222-0460	RH	1/2	1/8 x 1/16	.07	1	1/4 x 1/8	.13	10.4
0223-0460	LH	1/2	1/8 x 1/16	.07	1	1/4 x 1/8	.13	10.4
0224-0460	RH	1/2	1/8 x 1/16	.07	1-1/4	1/4 x 1/8	.13	9.9
0225-0460	LH	1/2	1/8 x 1/16	.07	1-1/4	1/4 x 1/8	.13	9.9
0226-0460	RH	5/8	1/8 x 1/16	.07	3/4	3/16 x 3/32	.10	10.0
0227-0460	LH	5/8	1/8 x 1/16	.07	3/4	3/16 x 3/32	.10	10.0
0228-0460	RH	5/8	1/8 x 1/16	.07	1	1/4 x 1/8	.13	9.6
0229-0460	LH	5/8	1/8 x 1/16	.07	1	1/4 x 1/8	.13	9.6
0230-0460	RH	5/8	1/8 x 1/16	.07	1-1/4	1/4 x 1/8	.13	9.1
0231-0460	LH	5/8	1/8 x 1/16	.07	1-1/4	1/4 x 1/8	.13	9.1
0232-0460	RH	3/4	3/16 x 3/32	.10	3/4	3/16 x 3/32	.10	10.0
0233-0460	LH	3/4	3/16 x 3/32	.10	3/4	3/16 x 3/32	.10	10.0
0234-0460	RH	3/4	3/16 x 3/32	.10	1	1/4 x 1/8	.13	9.6
0235-0460	LH	3/4	3/16 x 3/32	.10	1	1/4 x 1/8	.13	9.6
0236-0460	RH	3/4	3/16 x 3/32	.10	1-1/4	1/4 x 1/8	.13	9.1
0237-0460	LH	3/4	3/16 x 3/32	.10	1-1/4	1/4 x 1/8	.13	9.1

## APPLICATIONS

### YOU CAN'T FIND A MORE FLEXIBLE GEAR DRIVE

If the distances between take-ups are varied during operation, both shafts can be slid axially through the Float-A-Shaft. They're available in right or left hand drives to meet your exact requirements. And what's more, the shaft's direction is reversible to suit your changing operation.

### FLOAT-A-SHAFT IS EASILY INSTALLED

An ingenious installation technique and one piece assembly eliminates coupling and shaft alignment problems.

Tolomatic makes the best right angle gear drives you can buy. We're out to prove that no one can get you around a corner faster than Tolomatic.

*NOTE: Pillow block bearing supports are recommended on all Float-A-Shaft applications. Effectively mounted directly between the Float-A-Shaft unit and the load, the pillow block bearing supports will absorb any shaft deflection or sideloading and assure alignment.*

*NOTE: All Float-A-Shaft units have 3° to 5° of backlash on reversal of input.*

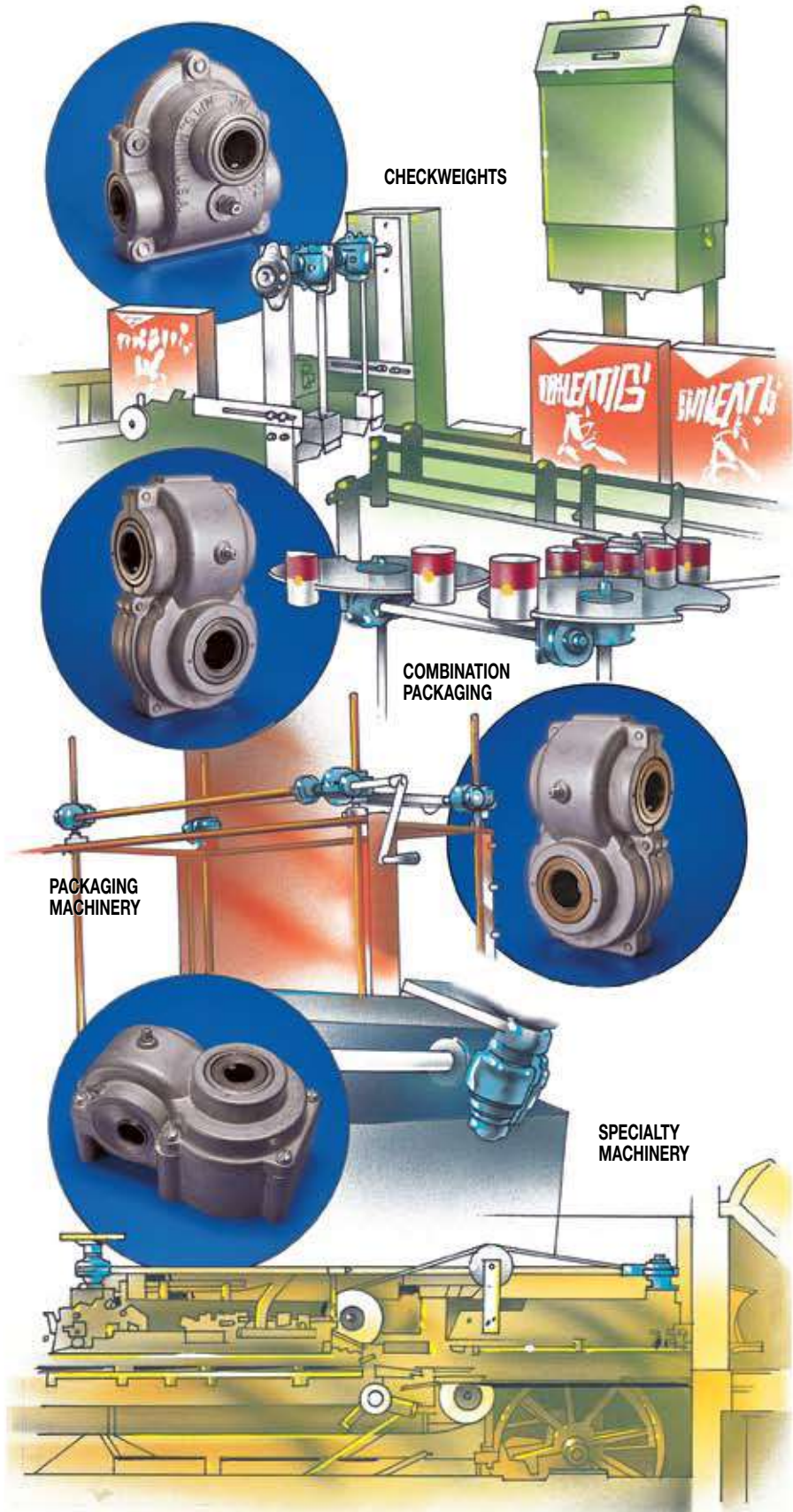

- SLIDE-RITE GEARBOX
- ENDURANCE TECHNOLOGY
- APPLICATION EXAMPLE
- COMPACT SERIES 1:1 RATIO
- STANDARD SERIES 1:1 RATIO
- STANDARD SERIES 3:2 RATIO
- STANDARD SERIES 2:1 RATIO
- FLOAT-A-SHAFT
- APPLICATIONS
- INTRODUCTION
- COMPACT SERIES 1:1 RATIO
- STANDARD SERIES 1:1 RATIO
- STANDARD SERIES 3:2 RATIO
- STANDARD SERIES 2:1 RATIO
- STANDARD SERIES 2.5:1 RATIO
- SELECTION
- INSTALLATION
- SHAFT & KEYWAY REQUIREMENTS

## INTRODUCTION

### TOLOMATIC IS TURNING THINGS AROUND

Tolomatic's Float-A-Shaft right angle gear drive was invented 50 years ago, and the competition still hasn't caught up. That's because Tolomatic gearboxes "float" on rotating shafts. Along with the Slide-Rite gearbox, no other design has the versatility, durability, safety, or the ease of operation as Float-A-Shaft.

Float-A-Shaft is a universal right angle gear drive coupling. It consists of two 45° helical gears that mesh at right angles, designed to turn power around any corner. Float-A-Shaft can be operated in either direction and can slide axially along the drive or driven shaft.

A lightweight aluminum housing encloses the gears, serving as a structural support and a lubricant reservoir. The gears mount directly on the shafts through keyways in the gears and shafts. These rugged and durable hardened helical gears have been field-proven for 50 years, assuring dependable operation. Yet with all of that, Float-A-Shaft retains a compact design well suited for use in tight quarters.

Float-A-Shaft's unique floating design maintains perfect alignment. It also eliminates dangerous chain sprocket drives and the additional adjustments required for chain drive applications.

### LOW TORQUE JOURNAL BEARING SERIES

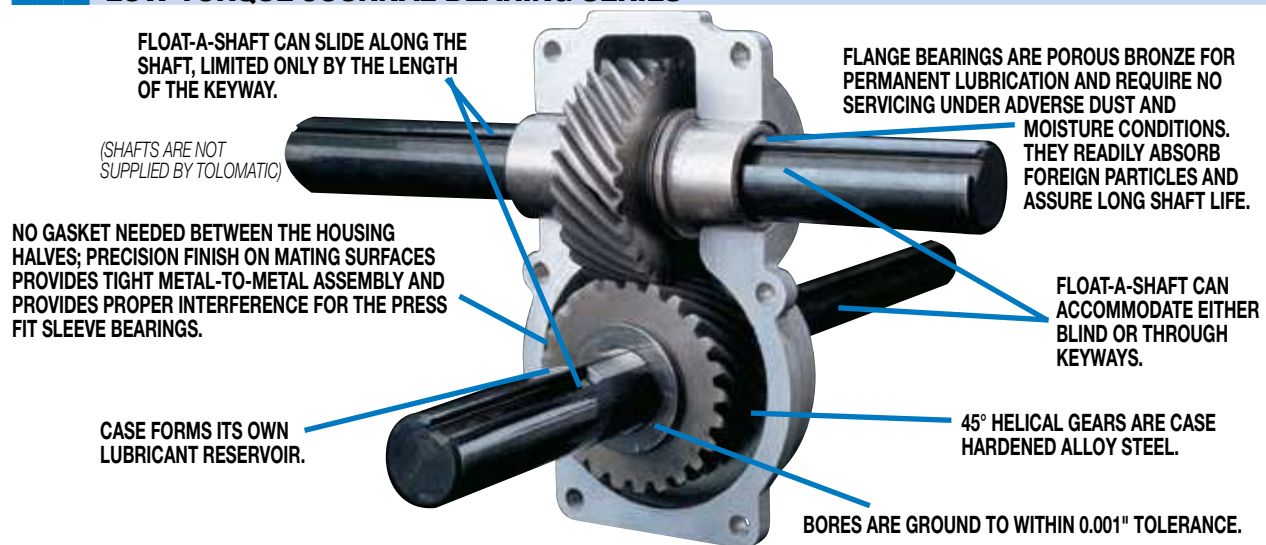

### HIGH TORQUE ROLLER BEARING SERIES

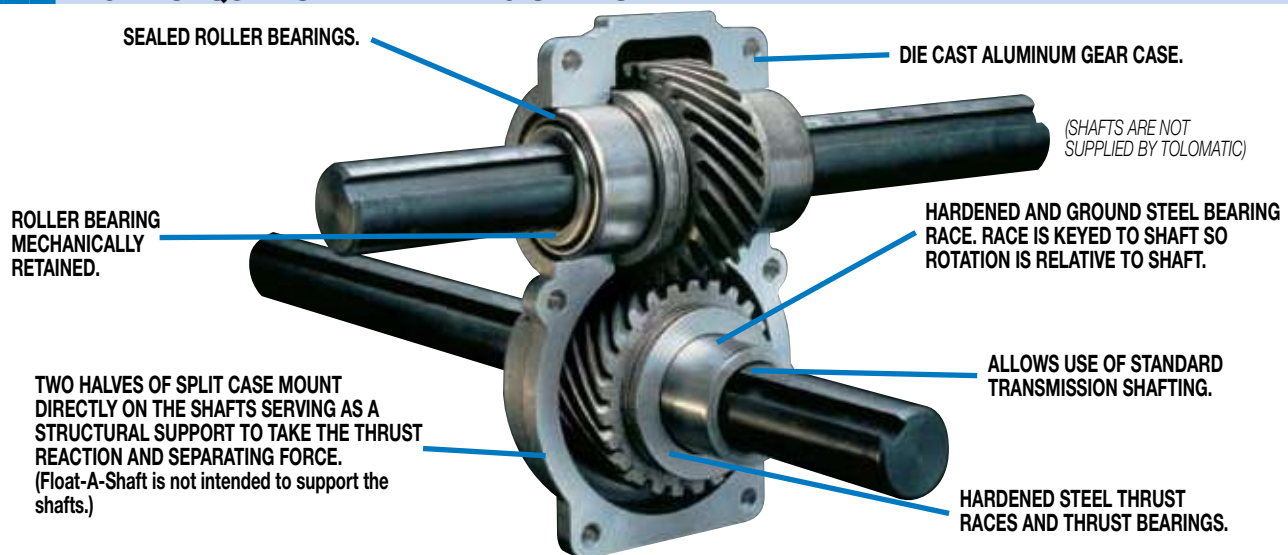



# Float-A-Shaft Gearbox

## COMPACT SERIES - 1:1 RATIO - US & METRIC

### AVAILABLE STYLES

#### Low Torque Journal Bearings

##### Standard

1-1/2 lbs. (0.68 kgs.)



##### Foot Mount

1-3/4 lbs. (0.79 kgs.)



### AVAILABLE STYLES

#### High Torque Roller Bearings

##### Standard

1-1/2 lbs. (0.68 kgs.)



##### Foot Mount

1-3/4 lbs. (0.79 kgs.)



### PERFORMANCE DATA

#### Low Torque Journal Bearings

**Torque and Efficiency vs RPM at Maximum Bearing Temperature**

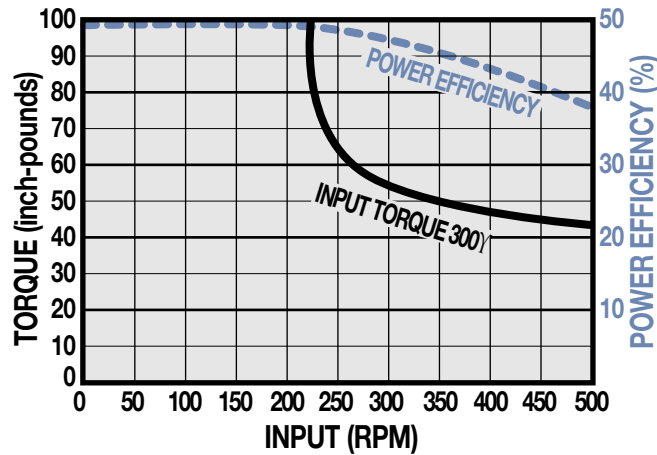

### PERFORMANCE DATA

#### High Torque Roller Bearings

**Torque and Efficiency vs RPM at Maximum Bearing Temperature**

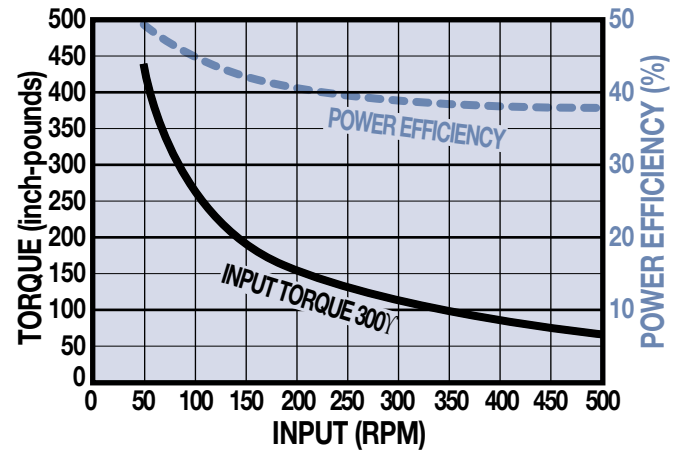



## COMPACT SERIES - 1:1 RATIO - US & METRIC

### DIMENSIONS: COMPACT STANDARD HIGH TORQUE & LOW TORQUE BEARINGS

Model Builder 3D CAD Available at: [www.tolomatic.com](http://www.tolomatic.com)

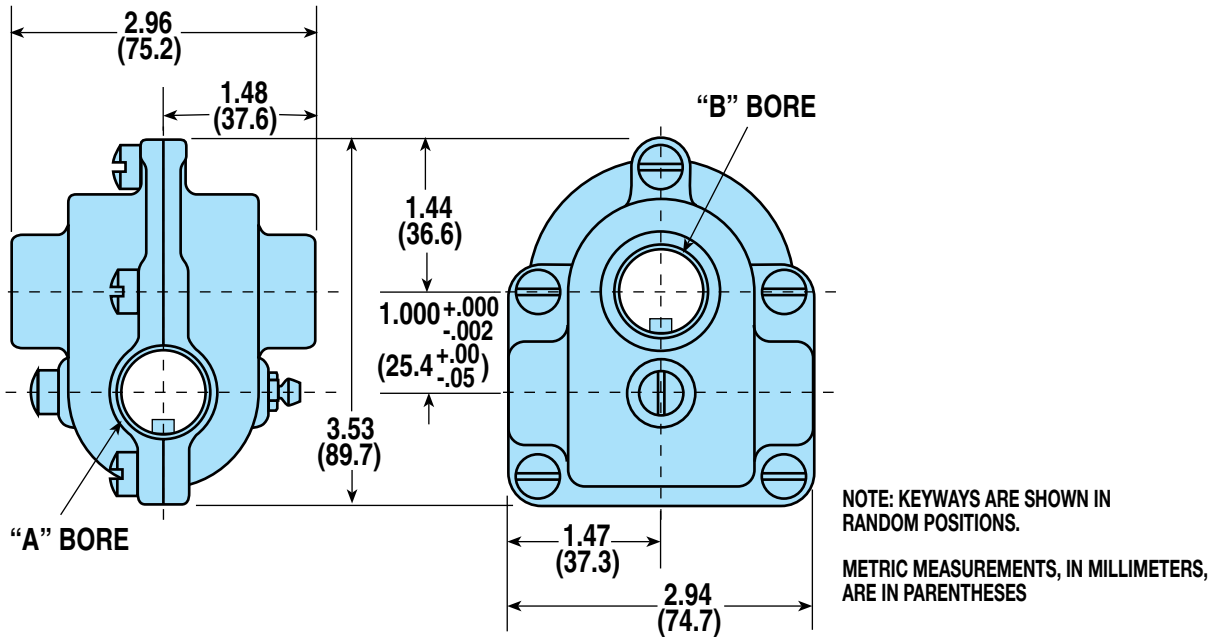

### Models and Bore Dimensions

#### U.S. - COMPACT STANDARD - 1:1

LOW TORQUE JOURNAL BEARING & HIGH TORQUE ROLLER BEARING

LOW TORQUE JOURNAL MODEL NO.	HIGH TORQUE ROLLER MODEL NO.	RH OR LH	"A" BORE		"B" BORE	
			BORE SIZE (IN.)	WxD KEYWAY (IN.)	BORE SIZE (IN.)	WxD KEYWAY (IN.)
0106-0000	0105-0100	RH	1/2	1/8 x 1/16	1/2	1/8 x 1/16
0105-0000	0106-0100	LH	1/2	1/8 x 1/16	1/2	1/8 x 1/16
0108-0000	0107-0100	RH	1/2	1/8 x 1/16	5/8	1/8 x 1/16
0107-0000	0108-0100	LH	1/2	1/8 x 1/16	5/8	1/8 x 1/16
0110-0000	0109-0100	RH	5/8	1/8 x 1/16	5/8	1/8 x 1/16
0109-0000	0110-0100	LH	5/8	1/8 x 1/16	5/8	1/8 x 1/16

#### METRIC - COMPACT STANDARD - 1:1

HIGH TORQUE ROLLER BEARING

HIGH TORQUE ROLLER MODEL NO.	RH OR LH	"A" BORE		"B" BORE	
		BORE SIZE (MM)	WxD KEYWAY (MM)	BORE SIZE (MM)	WxD KEYWAY (MM)
0120-0100	RH	12	4 x 2	12	4 x 2
0121-0100	LH	12	4 x 2	12	4 x 2
0122-0100	RH	12	4 x 2	15	5 x 2.5
0123-0100	LH	12	4 x 2	15	5 x 2.5
0124-0100	RH	15	5 x 2.5	15	5 x 2.5
0125-0100	LH	15	5 x 2.5	15	5 x 2.5

NOTE: METRIC SIZES AVAILABLE ONLY IN HIGH TORQUE ROLLER BEARING MODELS.

## COMPACT SERIES - 1:1 RATIO - US & METRIC

- SLIDE-RITE GEARBOX
- ENDURANCE TECHNOLOGY
- APPLICATION EXAMPLE
- COMPACT SERIES 1:1 RATIO
- STANDARD SERIES 1:1 RATIO
- STANDARD SERIES 3:2 RATIO
- STANDARD SERIES 2:1 RATIO
- FLOAT-A-SHAFT
- APPLICATIONS INTRODUCTION
- COMPACT SERIES 1:1 RATIO
- STANDARD SERIES 1:1 RATIO
- STANDARD SERIES 3:2 RATIO
- STANDARD SERIES 2:1 RATIO
- STANDARD SERIES 2.5:1 RATIO
- SELECTION
- INSTALLATION
- SHAFT & KEYWAY REQUIREMENTS

### DIMENSIONS: COMPACT FOOT MOUNT HIGH TORQUE & LOW TORQUE BEARINGS

Model Builder 3D CAD Available at: [www.tolomatic.com](http://www.tolomatic.com)

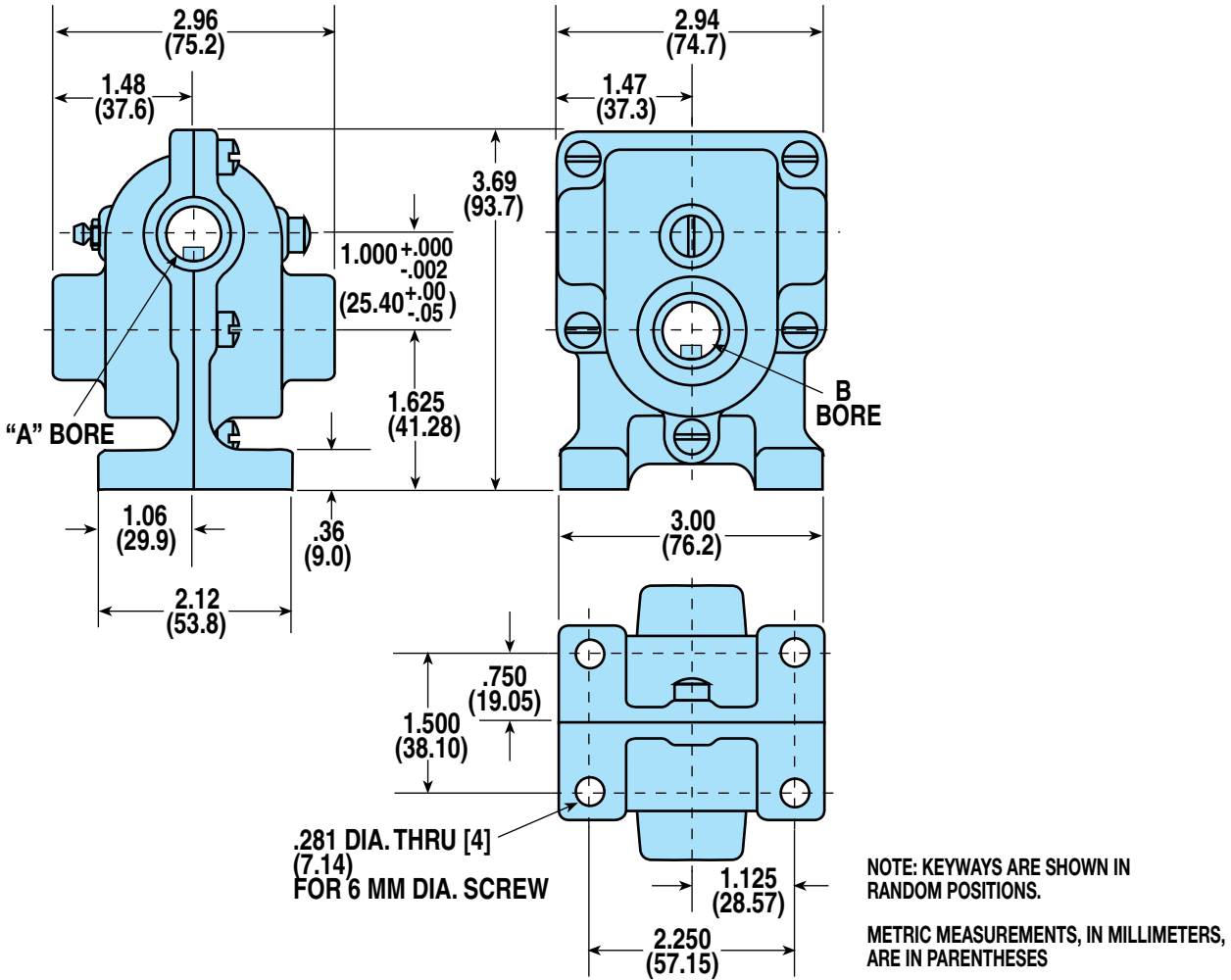

### Models and Bore Dimensions

#### U.S. - COMPACT FOOT MOUNT - 1:1

LOW TORQUE JOURNAL BEARING & HIGH TORQUE ROLLER BEARING

LOW TORQUE JOURNAL MODEL NO.	HIGH TORQUE ROLLER MODEL NO.	RH OR LH	"A" BORE		"B" BORE	
			BORE SIZE (IN.)	WxD KEYWAY (IN.)	BORE SIZE (IN.)	WxD KEYWAY (IN.)
0112-0000	0111-0100	RH	1/2	1/8 x 1/16	1/2	1/8 x 1/16
0111-0000	0112-0100	LH	1/2	1/8 x 1/16	1/2	1/8 x 1/16
0114-0000	0113-0100	RH	1/2	1/8 x 1/16	5/8	1/8 x 1/16
0113-0000	0114-0100	LH	1/2	1/8 x 1/16	5/8	1/8 x 1/16
0116-0000	0115-0100	RH	5/8	1/8 x 1/16	5/8	1/8 x 1/16
0115-0000	0116-0100	LH	5/8	1/8 x 1/16	5/8	1/8 x 1/16

#### METRIC - COMPACT FOOT MOUNT - 1:1 HIGH TORQUE ROLLER BEARING

HIGH TORQUE ROLLER MODEL NO.	RH OR LH	"A" BORE		"B" BORE	
		BORE SIZE (MM)	WxD KEYWAY (MM)	BORE SIZE (MM)	WxD KEYWAY (MM)
0126-0100	RH	12	4 x 2	12	4 x 2
0127-0100	LH	12	4 x 2	12	4 x 2
0128-0100	RH	12	4 x 2	15	5 x 2.5
0129-0100	LH	12	4 x 2	15	5 x 2.5
0130-0100	RH	15	5 x 2.5	15	5 x 2.5
0131-0100	LH	15	5 x 2.5	15	5 x 2.5

**NOTE: METRIC SIZES AVAILABLE ONLY IN HIGH TORQUE ROLLER BEARING MODELS.**

## STANDARD SERIES - 1:1 RATIO - US & METRIC

### AVAILABLE STYLES

#### Low Torque Journal Bearings

##### Standard

5 lbs. (2.27 kgs.)



##### Flat Base

5-3/4 lbs. (2.61 kgs.)



### AVAILABLE STYLES

#### High Torque Roller Bearings

##### Standard

5-1/2 lbs. (2.49 kgs.)



##### Flat Base

6-1/2 lbs. (2.95 kgs.)



### PERFORMANCE DATA

#### Low Torque Journal Bearings

**Torque and Efficiency vs RPM at Maximum Bearing Temperature**

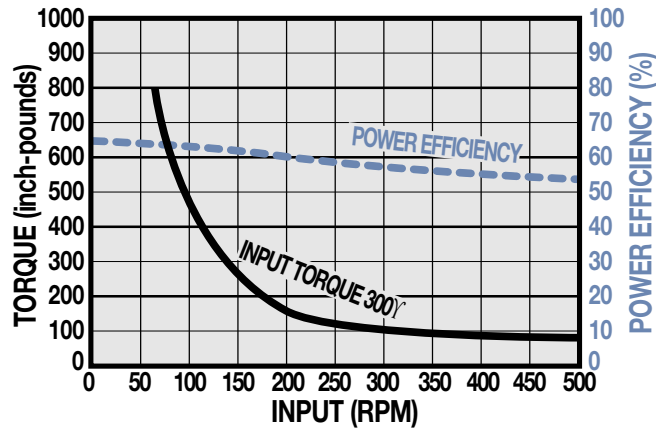

### PERFORMANCE DATA

#### High Torque Roller Bearings

**Torque and Efficiency vs RPM at Maximum Bearing Temperature**

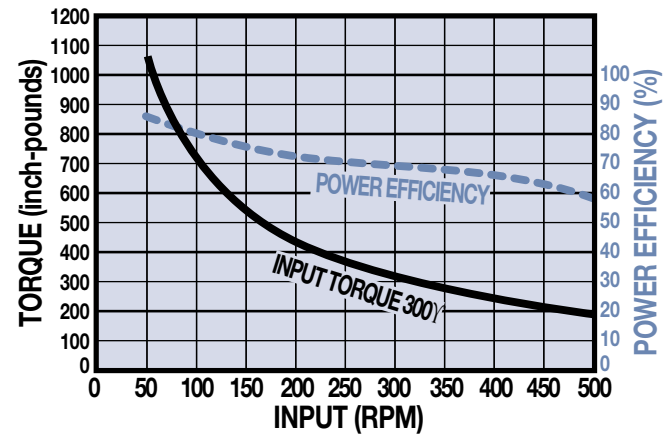

## STANDARD SERIES - 1:1 RATIO - US & METRIC

### DIMENSIONS: STANDARD HIGH TORQUE & LOW TORQUE BEARINGS

Model Builder 3D CAD Available at: [www.tolomatic.com](http://www.tolomatic.com)

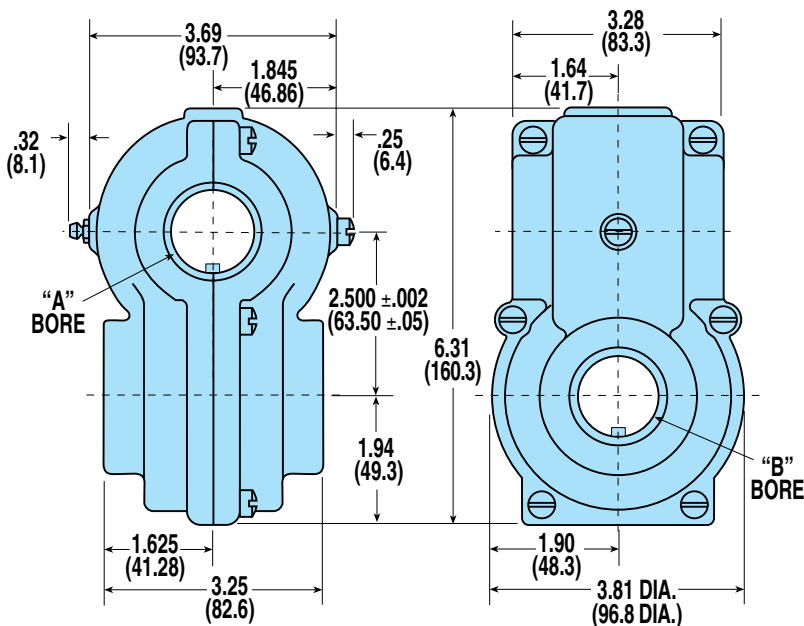

NOTE: KEYWAYS ARE SHOWN IN RANDOM POSITIONS.

METRIC MEASUREMENTS, IN MILLIMETERS, ARE IN PARENTHESES

### Models and Bore Dimensions

#### U.S. - STANDARD - 1:1

##### LOW TORQUE JOURNAL BEARING & HIGH TORQUE ROLLER BEARING

LOW TORQUE JOURNAL MODEL NO.	HIGH TORQUE ROLLER MODEL NO.	RH OR LH	"A" BORE		"B" BORE	
			BORE SIZE (IN.)	WxD KEYWAY (IN.)	BORE SIZE (IN.)	WxD KEYWAY (IN.)
0204-0000	0203-0200	RH	3/4	3/16 x 3/32	3/4	3/16 x 3/32
0203-0000	0204-0200	LH	3/4	3/16 x 3/32	3/4	3/16 x 3/32
0208-0000	0205-0200	RH	3/4	3/16 x 3/32	1	1/4 x 1/8
0207-0000	0206-0200	LH	3/4	3/16 x 3/32	1	1/4 x 1/8
0212-0000	0207-0200	RH	3/4	3/16 x 3/32	1-1/4	1/4 x 1/8
0211-0000	0208-0200	LH	3/4	3/16 x 3/32	1-1/4	1/4 x 1/8
0216-0000	NA	RH	3/4	3/16 x 3/32	1-1/2	3/8 x 3/16
0215-0000	NA	LH	3/4	3/16 x 3/32	1-1/2	3/8 x 3/16
0220-0000	0209-0200	RH	1	1/4 x 1/8	1	1/4 x 1/8
0219-0000	0210-0200	LH	1	1/4 x 1/8	1	1/4 x 1/8
0224-0000	0211-0200	RH	1	1/4 x 1/8	1-1/4	1/4 x 1/8
0223-0000	0212-0200	LH	1	1/4 x 1/8	1-1/4	1/4 x 1/8
0228-0000	NA	RH	1	1/4 x 1/8	1-1/2	3/8 x 3/16
0227-0000	NA	LH	1	1/4 x 1/8	1-1/2	3/8 x 3/16
0232-0000	0213-0200	RH	1-1/4	1/4 x 1/8	1-1/4	1/4 x 1/8
0231-0000	0214-0200	LH	1-1/4	1/4 x 1/8	1-1/4	1/4 x 1/8
0236-0000	NA	RH	1-1/4	1/4 x 1/8	1-1/2	3/8 x 3/16
0235-0000	NA	LH	1-1/4	1/4 x 1/8	1-1/2	3/8 x 3/16
0240-0000	NA	RH	1-1/2	3/8 x 3/16	1-1/2	3/8 x 3/16
0239-0000	NA	LH	1-1/2	3/8 x 3/16	1-1/2	3/8 x 3/16

#### METRIC - STANDARD - 1:1 HIGH TORQUE ROLLER BEARING

HIGH TORQUE ROLLER MODEL NO.	RH OR LH	"A" BORE		"B" BORE	
		BORE SIZE (MM)	WxD KEYWAY (MM)	BORE SIZE (MM)	WxD KEYWAY (MM)
0308-0200	RH	20	6 x 3	20	6 x 3
0309-0200	LH	20	6 x 3	20	6 x 3
0310-0200	RH	20	6 x 3	25	8 x 3.5
0311-0200	LH	20	6 x 3	25	8 x 3.5
0312-0200	RH	20	6 x 3	30	8 x 3.5
0313-0200	LH	20	6 x 3	30	8 x 3.5
0314-0200	RH	25	8 x 3.5	25	8 x 3.5
0315-0200	LH	25	8 x 3.5	25	8 x 3.5
0316-0200	RH	25	8 x 3.5	30	8 x 3.5
0317-0200	LH	25	8 x 3.5	30	8 x 3.5
0318-0200	RH	30	8 x 3.5	30	8 x 3.5
0319-0200	LH	30	8 x 3.5	30	8 x 3.5

NOTE: METRIC SIZES AVAILABLE ONLY IN HIGH TORQUE ROLLER BEARING MODELS.



## STANDARD SERIES - 1:1 RATIO - US & METRIC

**DIMENSIONS: STANDARD FLAT BASE HIGH TORQUE & LOW TORQUE BEARINGS**

Model Builder 3D CAD Available at: [www.tolomatic.com](http://www.tolomatic.com)

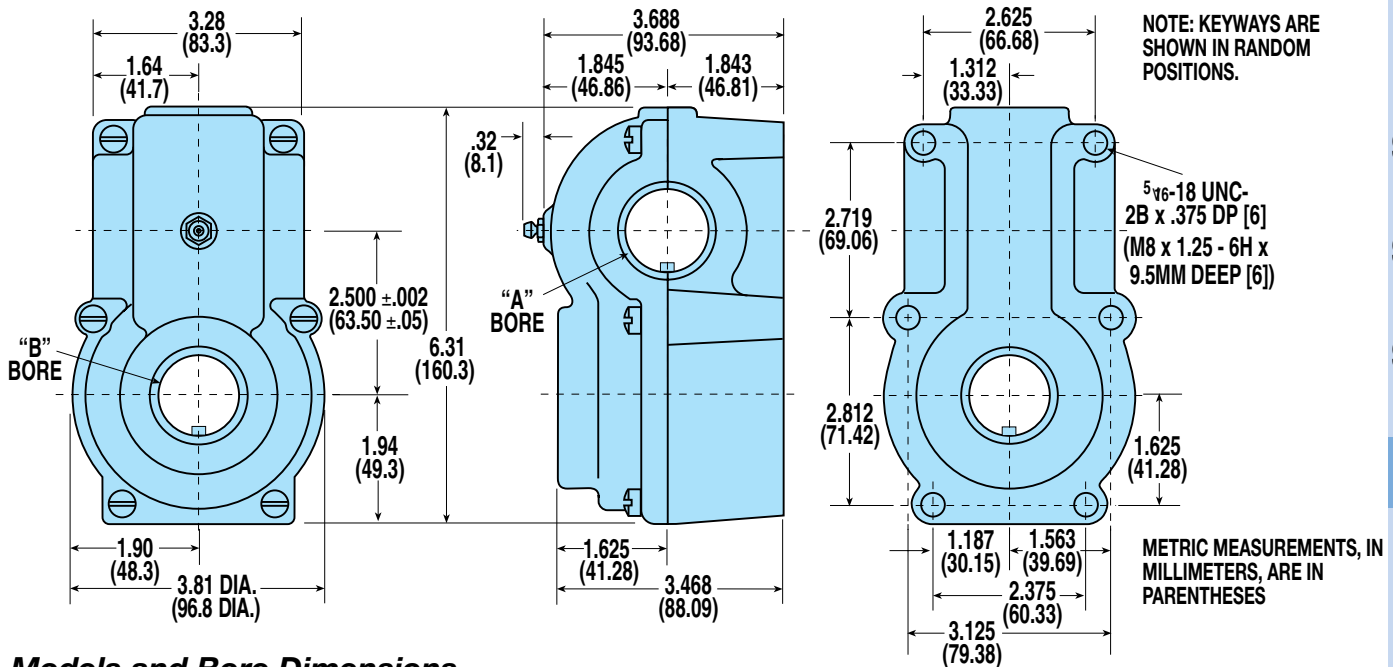

### Models and Bore Dimensions

#### U.S. - STANDARD FLAT BASE - 1:1

LOW TORQUE JOURNAL BEARING & HIGH TORQUE ROLLER BEARING

LOW TORQUE JOURNAL MODEL NO.	HIGH TORQUE ROLLER MODEL NO.	RH OR LH	"A" BORE		"B" BORE	
			BORE SIZE (IN.)	WxD KEYWAY (IN.)	BORE SIZE (IN.)	WxD KEYWAY (IN.)
0245-0000	0217-0200	RH	3/4	3/16 x 3/32	3/4	3/16 x 3/32
0246-0000	0218-0200	LH	3/4	3/16 x 3/32	3/4	3/16 x 3/32
0247-0000	0219-0200	RH	3/4	3/16 x 3/32	1	1/4 x 1/8
0248-0000	0220-0200	LH	3/4	3/16 x 3/32	1	1/4 x 1/8
0249-0000	0221-0200	RH	3/4	3/16 x 3/32	1-1/4	1/4 x 1/8
0250-0000	0222-0200	LH	3/4	3/16 x 3/32	1-1/4	1/4 x 1/8
0251-0000	NA	RH	3/4	3/16 x 3/32	1-1/2	3/8 x 3/16
0252-0000	NA	LH	3/4	3/16 x 3/32	1-1/2	3/8 x 3/16
0253-0000	0223-0200	RH	1	1/4 x 1/8	1	1/4 x 1/8
0254-0000	0224-0200	LH	1	1/4 x 1/8	1	1/4 x 1/8
0255-0000	0225-0200	RH	1	1/4 x 1/8	1-1/4	1/4 x 1/8
0256-0000	0226-0200	LH	1	1/4 x 1/8	1-1/4	1/4 x 1/8
0257-0000	NA	RH	1	1/4 x 1/8	1-1/2	3/8 x 3/16
0258-0000	NA	LH	1	1/4 x 1/8	1-1/2	3/8 x 3/16
0269-0000	0227-0200	RH	1-1/4	1/4 x 1/8	1-1/4	1/4 x 1/8
0270-0000	0228-0200	LH	1-1/4	1/4 x 1/8	1-1/4	1/4 x 1/8
0271-0000	NA	RH	1-1/4	1/4 x 1/8	1-1/2	3/8 x 3/16
0272-0000	NA	LH	1-1/4	1/4 x 1/8	1-1/2	3/8 x 3/16
0273-0000	NA	RH	1-1/2	3/8 x 3/16	1-1/2	3/8 x 3/16
0274-0000	NA	LH	1-1/2	3/8 x 3/16	1-1/2	3/8 x 3/16

#### METRIC - STANDARD FLAT BASE - 1:1 HIGH TORQUE ROLLER BEARING

HIGH TORQUE ROLLER MODEL NO.	RH OR LH	"A" BORE		"B" BORE	
		BORE SIZE (MM)	WxD KEYWAY (MM)	BORE SIZE (MM)	WxD KEYWAY (MM)
0328-0200	RH	20	6 x 3	20	6 x 3
0329-0200	LH	20	6 x 3	20	6 x 3
0330-0200	RH	20	6 x 3	25	8 x 3.5
0331-0200	LH	20	6 x 3	25	8 x 3.5
0332-0200	RH	20	6 x 3	30	8 x 3.5
0333-0200	LH	20	6 x 3	30	8 x 3.5
0334-0200	RH	25	8 x 3.5	25	8 x 3.5
0335-0200	LH	25	8 x 3.5	25	8 x 3.5
0336-0200	RH	25	8 x 3.5	30	8 x 3.5
0337-0200	LH	25	8 x 3.5	30	8 x 3.5
0338-0200	RH	30	8 x 3.5	30	8 x 3.5
0339-0200	LH	30	8 x 3.5	30	8 x 3.5

NOTE: METRIC SIZES AVAILABLE ONLY IN HIGH TORQUE ROLLER BEARING MODELS.

# Float-A-Shaft Gearbox

## STANDARD SERIES - 3:2 RATIO - US & METRIC

### AVAILABLE STYLES

#### Low Torque Journal Bearings

##### Standard

5-3/4 lbs. (2.61 kgs.)

##### Flat Base

5-3/4 lbs. (2.61 kgs.)



### AVAILABLE STYLES

#### High Torque Roller Bearings

##### Standard

6 lbs. (2.72 kgs.)

##### Flat Base

6-3/4 lbs. (3.06 kgs.)



### PERFORMANCE DATA

#### Low Torque Journal Bearings

**Torque and Efficiency vs RPM at Maximum Bearing Temperature**

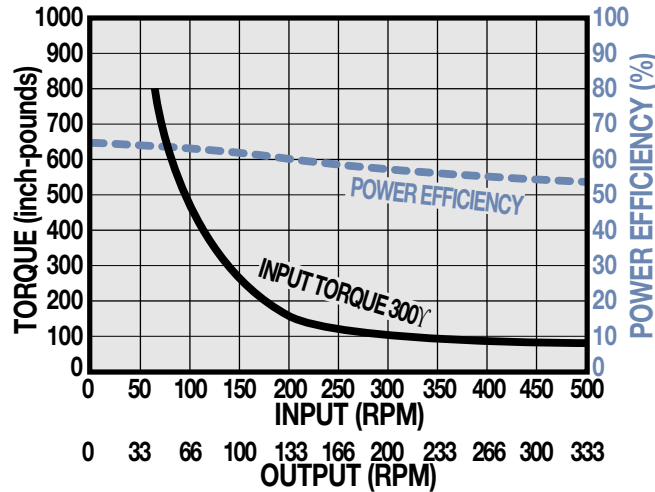

### PERFORMANCE DATA

#### High Torque Roller Bearings

**Torque and Efficiency vs RPM at Maximum Bearing Temperature**

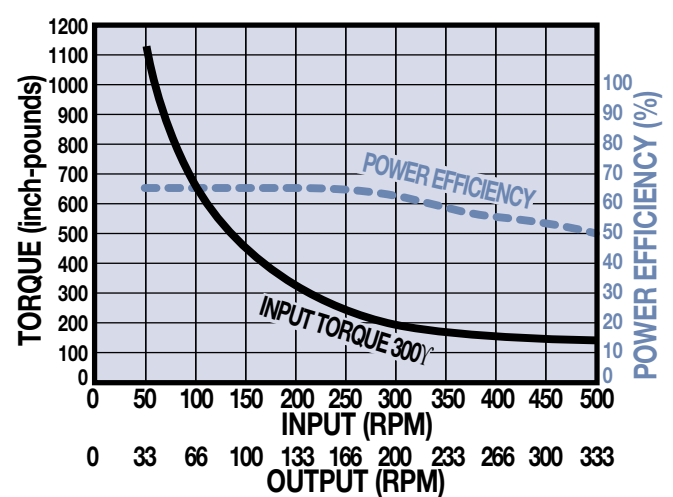

## STANDARD SERIES - 3:2 RATIO - US & METRIC

### DIMENSIONS: STANDARD HIGH TORQUE & LOW TORQUE BEARINGS

Model Builder 3D CAD Available at: [www.tolomatic.com](http://www.tolomatic.com)

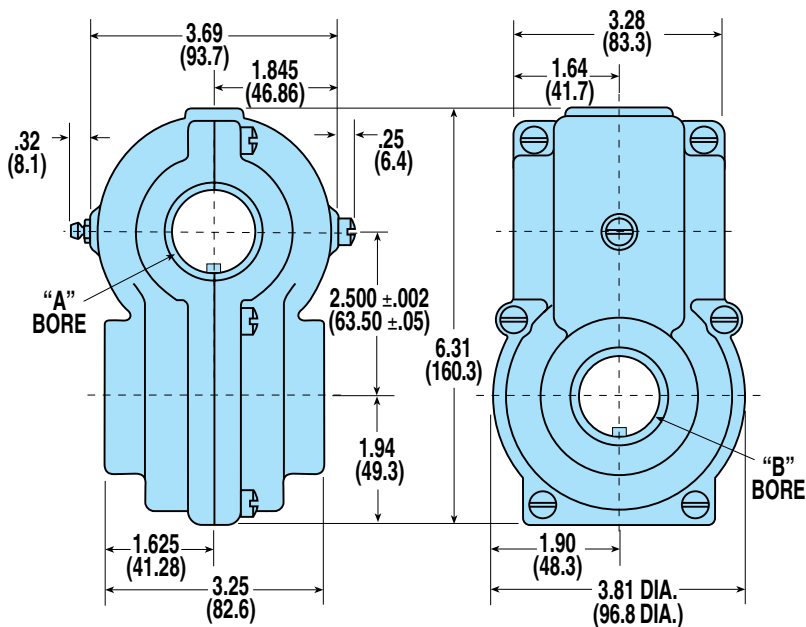

NOTE: KEYWAYS ARE SHOWN IN RANDOM POSITIONS.

METRIC MEASUREMENTS, IN MILLIMETERS, ARE IN PARENTHESES

### Models and Bore Dimensions

#### U.S. - STANDARD - 3:2

##### LOW TORQUE JOURNAL BEARING & HIGH TORQUE ROLLER BEARING

LOW TORQUE JOURNAL MODEL NO.	HIGH TORQUE ROLLER MODEL NO.	RH OR LH	"A" BORE		"B" BORE	
			BORE SIZE (IN.)	WxD KEYWAY (IN.)	BORE SIZE (IN.)	WxD KEYWAY (IN.)
0241-0000	0231-0200	RH	3/4	3/16 x 3/32	3/4	3/16 x 3/32
0242-0000	0232-0200	LH	3/4	3/16 x 3/32	3/4	3/16 x 3/32
0259-0000	0233-0200	RH	3/4	3/16 x 3/32	1	1/4 x 1/8
0260-0000	0234-0200	LH	3/4	3/16 x 3/32	1	1/4 x 1/8
NA	0235-0200	RH	3/4	3/16 x 3/32	1-1/4	1/4 x 1/8
NA	0236-0200	LH	3/4	3/16 x 3/32	1-1/4	1/4 x 1/8
0261-0000	0237-0200	RH	1	1/4 x 1/8	1	1/4 x 1/8
0262-0000	0238-0200	LH	1	1/4 x 1/8	1	1/4 x 1/8
0263-0000	0239-0200	RH	1	1/4 x 1/8	1-1/4	1/4 x 1/8
0264-0000	0240-0200	LH	1	1/4 x 1/8	1-1/4	1/4 x 1/8
0265-0000	0241-0200	RH	1-1/4	1/4 x 1/8	1-1/4	1/4 x 1/8
0266-0000	0242-0200	LH	1-1/4	1/4 x 1/8	1-1/4	1/4 x 1/8

NOTE: FOR LOW TORQUE JOURNAL BEARING MODELS  
THE "A" BORE CONTAINS THE 20 TOOTH GEAR. THE "B" BORE CONTAINS THE 30 TOOTH GEAR.

NOTE: FOR HIGH TORQUE ROLLER BEARING MODELS  
THE "A" BORE CONTAINS THE 20 TOOTH GEAR. THE "B" BORE CONTAINS THE 30 TOOTH GEAR.

#### METRIC - STANDARD - 3:2 HIGH TORQUE ROLLER BEARING

HIGH TORQUE ROLLER MODEL NO.	RH OR LH	"A" BORE		"B" BORE	
		BORE SIZE (MM)	WxD KEYWAY (MM)	BORE SIZE (MM)	WxD KEYWAY (MM)
0354-0200	RH	25	8 x 3.5	25	8 x 3.5
0355-0200	LH	25	8 x 3.5	25	8 x 3.5
0356-0200	RH	25	8 x 3.5	30	8 x 3.5
0357-0200	LH	25	8 x 3.5	30	8 x 3.5
0358-0200	RH	30	8 x 3.5	30	8 x 3.5
0359-0200	LH	30	8 x 3.5	30	8 x 3.5

NOTE: METRIC SIZES AVAILABLE ONLY IN HIGH TORQUE ROLLER BEARING MODELS.

## STANDARD SERIES - 3:2 RATIO - US & METRIC

### DIMENSIONS: STANDARD FLAT BASE HIGH TORQUE & LOW TORQUE BEARINGS

Model Builder 3D CAD Available at: [www.tolomatic.com](http://www.tolomatic.com)

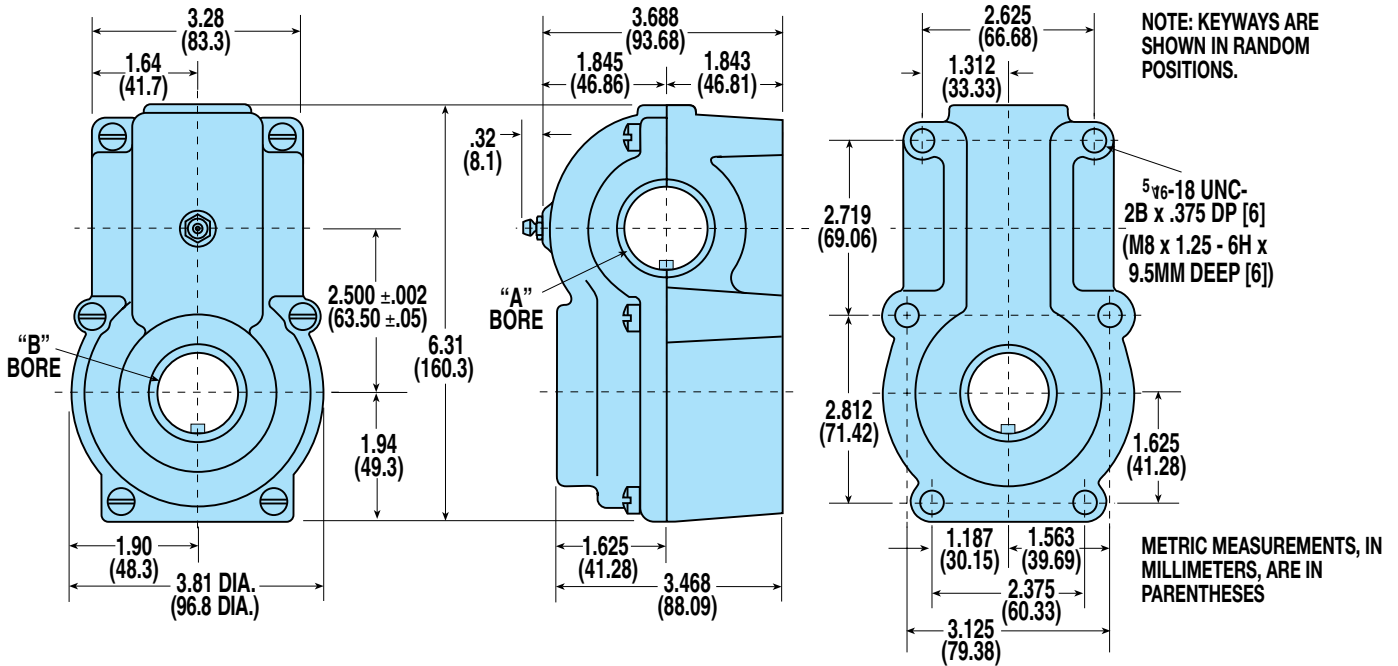

### Models and Bore Dimensions

#### U.S. - STANDARD FLAT BASE - 3:2

##### LOW TORQUE JOURNAL BEARING & HIGH TORQUE ROLLER BEARING

LOW TORQUE JOURNAL MODEL NO.	HIGH TORQUE ROLLER MODEL NO.	RH OR LH	"A" BORE		"B" BORE	
			BORE SIZE (IN.)	WXD KEYWAY (IN.)	BORE SIZE (IN.)	WXD KEYWAY (IN.)
0277-0000	0245-0200	RH	3/4	3/16 x 3/32	3/4	3/16 x 3/32
0278-0000	0246-0200	LH	3/4	3/16 x 3/32	3/4	3/16 x 3/32
0279-0000	0247-0200	RH	3/4	3/16 x 3/32	1	1/4 x 1/8
0280-0000	0248-0200	LH	3/4	3/16 x 3/32	1	1/4 x 1/8
NA	0249-0200	RH	3/4	3/16 x 3/32	1-1/4	1/4 x 1/8
NA	0250-0200	LH	3/4	3/16 x 3/32	1-1/4	1/4 x 1/8
0281-0000	0251-0200	RH	1	1/4 x 1/8	1	1/4 x 1/8
0282-0000	0252-0200	LH	1	1/4 x 1/8	1	1/4 x 1/8
0283-0000	0253-0200	RH	1	1/4 x 1/8	1-1/4	1/4 x 1/8
0284-0000	0254-0200	LH	1	1/4 x 1/8	1-1/4	1/4 x 1/8
0285-0000	0255-0200	RH	1-1/4	1/4 x 1/8	1-1/4	1/4 x 1/8
0286-0000	0256-0200	LH	1-1/4	1/4 x 1/8	1-1/4	1/4 x 1/8

#### METRIC - STANDARD FLAT BASE - 3:2 HIGH TORQUE ROLLER BEARING

HIGH TORQUE ROLLER MODEL NO.	RH OR LH	"A" BORE		"B" BORE	
		BORE SIZE (MM)	WXD KEYWAY (MM)	BORE SIZE (MM)	WXD KEYWAY (MM)
0374-0200	RH	25	8 x 3.5	25	8 x 3.5
0375-0200	LH	25	8 x 3.5	25	8 x 3.5
0376-0200	RH	25	8 x 3.5	30	8 x 3.5
0377-0200	LH	25	8 x 3.5	30	8 x 3.5
0378-0200	RH	30	8 x 3.5	30	8 x 3.5
0379-0200	LH	30	8 x 3.5	30	8 x 3.5

NOTE: FOR LOW TORQUE JOURNAL BEARING MODELS  
THE "A" BORE CONTAINS THE 20 TOOTH GEAR. THE "B" BORE CONTAINS THE 30 TOOTH GEAR.

NOTE: FOR HIGH TORQUE ROLLER BEARING MODELS  
THE "A" BORE CONTAINS THE 20 TOOTH GEAR. THE "B" BORE CONTAINS THE 30 TOOTH GEAR.



## STANDARD SERIES - 2:1 RATIO - US & METRIC

### AVAILABLE STYLES

#### Low Torque Journal Bearings

##### Standard

3-1/2 lbs. (1.59 kgs.)



### AVAILABLE STYLES

#### High Torque Roller Bearings

##### Standard

6-1/4 lbs. (2.84 kgs.)



##### Flat Base

6-3/4 lbs. (3.06 kgs.)



### PERFORMANCE DATA

#### Low Torque Journal Bearings

**Torque and Efficiency vs RPM at Maximum Bearing Temperature**

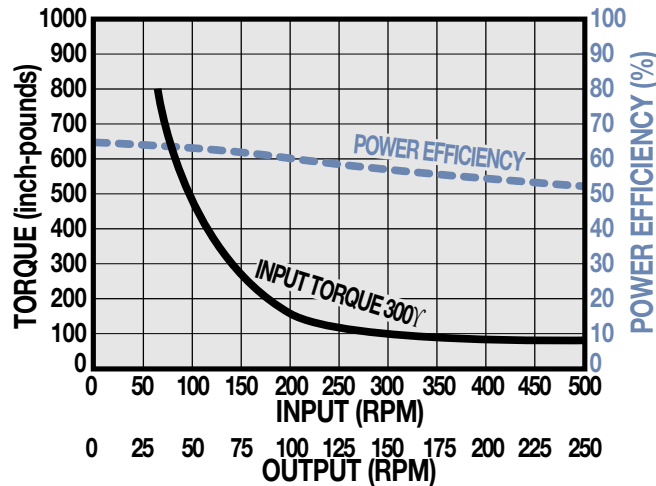

### PERFORMANCE DATA

#### High Torque Roller Bearings

**Torque and Efficiency vs RPM at Maximum Bearing Temperature**

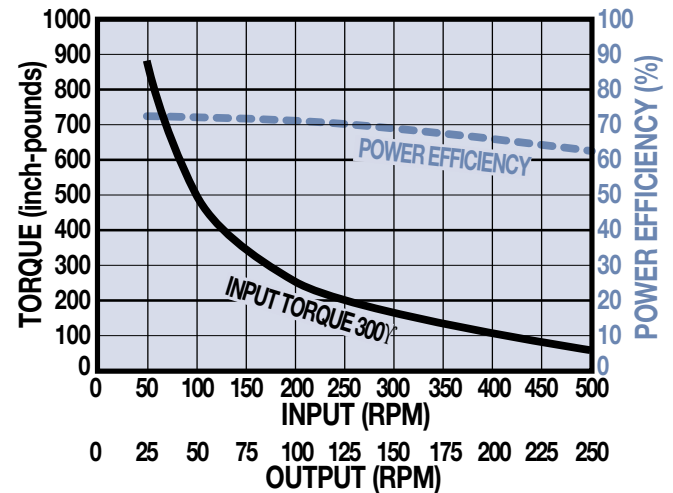

## STANDARD SERIES - 2:1 RATIO - US & METRIC

SLIDE-RITE GEARBOX

ENDURANCE TECHNOLOGY

APPLICATION EXAMPLE

COMPACT SERIES 1:1 RATIO

STANDARD SERIES 1:1 RATIO

STANDARD SERIES 3:2 RATIO

STANDARD SERIES 2:1 RATIO

FLOAT-A-SHAFT

APPLICATIONS INTRODUCTION

COMPACT SERIES 1:1 RATIO

STANDARD SERIES 1:1 RATIO

STANDARD SERIES 3:2 RATIO

STANDARD SERIES 2:1 RATIO

STANDARD SERIES 2.5:1 RATIO

SELECTION

INSTALLATION

SHAFT & KEYWAY REQUIREMENTS

### DIMENSIONS: STANDARD LOW TORQUE BEARINGS

Model Builder 3D CAD Available at: [www.tolomatic.com](http://www.tolomatic.com)

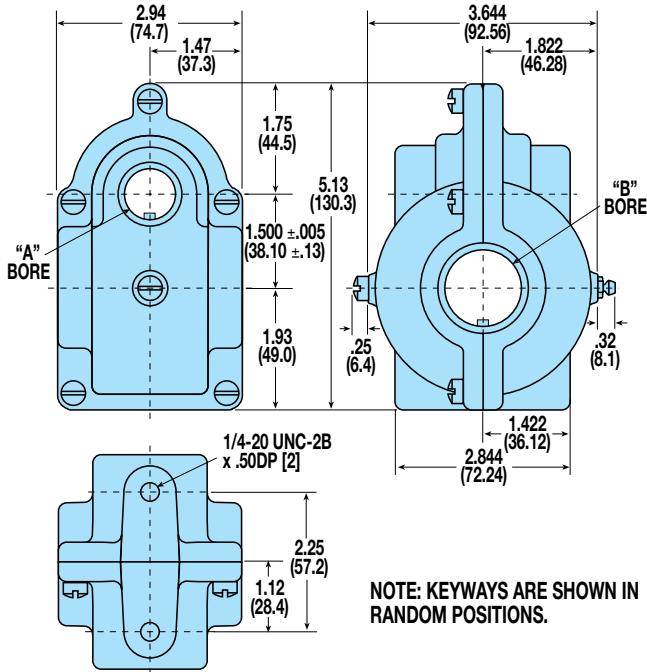

### DIMENSIONS: STANDARD HIGH TORQUE BEARINGS

Model Builder 3D CAD Available at: [www.tolomatic.com](http://www.tolomatic.com)

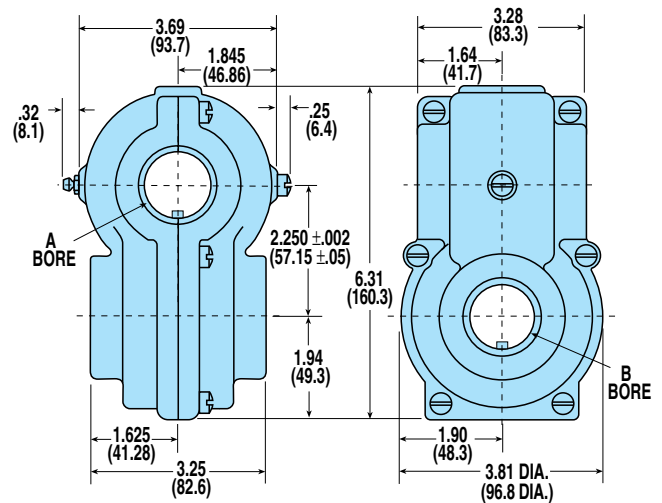

### Models and Bore Dimensions

#### U.S. - STANDARD - 2:1

##### LOW TORQUE JOURNAL BEARING & HIGH TORQUE ROLLER BEARING

LOW TORQUE JOURNAL MODEL NO.	HIGH TORQUE ROLLER MODEL NO.	RH OR LH	"A" BORE		"B" BORE	
			BORE SIZE (IN.)	WxD KEYWAY (IN.)	BORE SIZE (IN.)	WxD KEYWAY (IN.)
0304-0000	0259-0200	RH	1/2	1/8 x 1/16	3/4	3/16 x 3/32
0303-0000	0260-0200	LH	1/2	1/8 x 1/16	3/4	3/16 x 3/32
0308-0000	0261-0200	RH	1/2	1/8 x 1/16	1	1/4 x 1/8
0307-0000	0262-0200	LH	1/2	1/8 x 1/16	1	1/4 x 1/8
0312-0000	0263-0200	RH	1/2	1/8 x 1/16	1-1/4	1/4 x 1/8
0311-0000	0264-0200	LH	1/2	1/8 x 1/16	1-1/4	1/4 x 1/8
0318-0000	0265-0200	RH	5/8	1/8 x 1/16	3/4	3/16 x 3/32
0317-0000	0266-0200	LH	5/8	1/8 x 1/16	3/4	3/16 x 3/32
0322-0000	0267-0200	RH	5/8	1/8 x 1/16	1	1/4 x 1/8
0321-0000	0268-0200	LH	5/8	1/8 x 1/16	1	1/4 x 1/8
0326-0000	0269-0200	RH	5/8	1/8 x 1/16	1-1/4	1/4 x 1/8
0325-0000	0270-0200	LH	5/8	1/8 x 1/16	1-1/4	1/4 x 1/8
NA	0271-0200	RH	3/4	3/16 x 3/32	3/4	3/16 x 3/32
NA	0272-0200	LH	3/4	3/16 x 3/32	3/4	3/16 x 3/32
NA	0273-0200	RH	3/4	3/16 x 3/32	1	1/4 x 1/8
NA	0274-0200	LH	3/4	3/16 x 3/32	1	1/4 x 1/8
NA	0275-0200	RH	3/4	3/16 x 3/32	1-1/4	1/4 x 1/8
NA	0276-0200	LH	3/4	3/16 x 3/32	1-1/4	1/4 x 1/8

NOTE: FOR LOW TORQUE JOURNAL BEARING MODELS: THE "A" BORE CONTAINS THE 10 TOOTH GEAR. THE "B" BORE CONTAINS THE 20 TOOTH GEAR.

#### METRIC - STANDARD - 2:1 HIGH TORQUE ROLLER BEARING

HIGH TORQUE ROLLER MODEL NO.	RH OR LH	"A" BORE		"B" BORE	
		BORE SIZE (MM)	WxD KEYWAY (MM)	BORE SIZE (MM)	WxD KEYWAY (MM)
0390-0200	RH	15	5 x 2.5	20	6 x 3
0391-0200	LH	15	5 x 2.5	20	6 x 3
0392-0200	RH	15	5 x 2.5	25	8 x 3.5
0393-0200	LH	15	5 x 2.5	25	8 x 3.5
0394-0200	RH	15	5 x 2.5	30	8 x 3.5
0395-0200	LH	15	5 x 2.5	30	8 x 3.5

NOTE: METRIC SIZES AVAILABLE ONLY IN HIGH TORQUE ROLLER BEARING MODELS.

NOTE: FOR HIGH TORQUE ROLLER BEARING MODELS: THE "A" BORE CONTAINS THE 15 TOOTH GEAR. THE "B" BORE CONTAINS THE 30 TOOTH GEAR.

## STANDARD SERIES - 2:1 RATIO - US & METRIC

### DIMENSIONS: STANDARD FLAT BASE HIGH TORQUE BEARINGS

Model Builder 3D CAD Available at: [www.tolomatic.com](http://www.tolomatic.com)

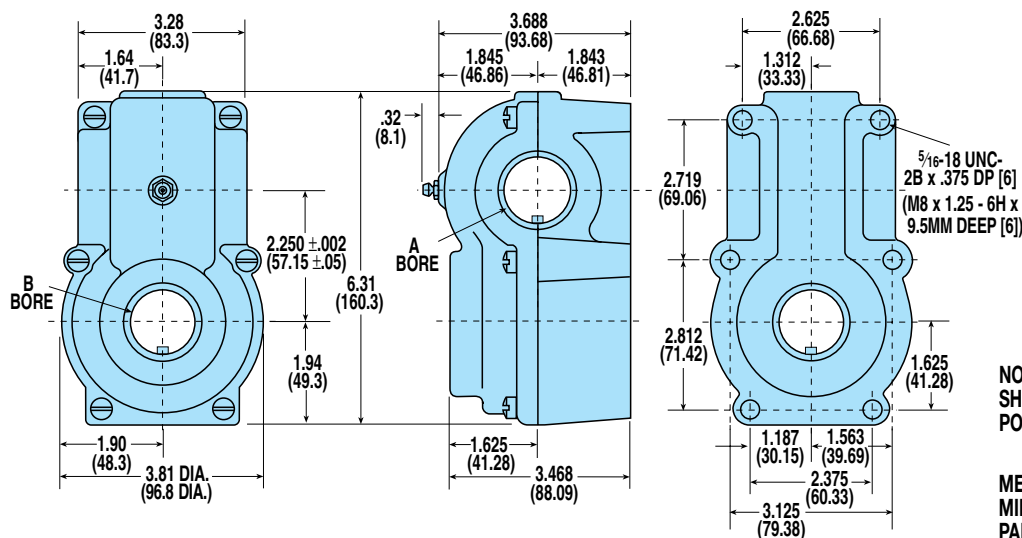

### Models and Bore Dimensions

#### U.S.- STANDARD FLAT BASE - 2:1 HIGH TORQUE ROLLER BEARING

HIGH TORQUE ROLLER MODEL NO.	RH OR LH	"A" BORE		"B" BORE	
		BORE SIZE (IN.)	WxD KEYWAY (IN.)	BORE SIZE (IN.)	WxD KEYWAY (IN.)
0279-0200	RH	1/2	1/8 x 1/16	3/4	3/16 x 3/32
0280-0200	LH	1/2	1/8 x 1/16	3/4	3/16 x 3/32
0281-0200	RH	1/2	1/8 x 1/16	1	1/4 x 1/8
0282-0200	LH	1/2	1/8 x 1/16	1	1/4 x 1/8
0283-0200	RH	1/2	1/8 x 1/16	1-1/4	1/4 x 1/8
0284-0200	LH	1/2	1/8 x 1/16	1-1/4	1/4 x 1/8
0285-0200	RH	5/8	1/8 x 1/16	3/4	3/16 x 3/32
0286-0200	LH	5/8	1/8 x 1/16	3/4	3/16 x 3/32
0287-0200	RH	5/8	1/8 x 1/16	1	1/4 x 1/8
0288-0200	LH	5/8	1/8 x 1/16	1	1/4 x 1/8
0289-0200	RH	5/8	1/8 x 1/16	1-1/4	1/4 x 1/8
0290-0200	LH	5/8	1/8 x 1/16	1-1/4	1/4 x 1/8
0291-0200	RH	3/4	3/16 x 3/32	3/4	3/16 x 3/32
0292-0200	LH	3/4	3/16 x 3/32	3/4	3/16 x 3/32
0293-0200	RH	3/4	3/16 x 3/32	1	1/4 x 1/8
0294-0200	LH	3/4	3/16 x 3/32	1	1/4 x 1/8
0295-0200	RH	3/4	3/16 x 3/32	1-1/4	1/4 x 1/8
0296-0200	LH	3/4	3/16 x 3/32	1-1/4	1/4 x 1/8

#### METRIC - STANDARD FLAT BASE - 2:1 HIGH TORQUE ROLLER BEARING

HIGH TORQUE ROLLER MODEL NO.	RH OR LH	"A" BORE		"B" BORE	
		BORE SIZE (MM)	WxD KEYWAY (MM)	BORE SIZE (MM)	WxD KEYWAY (MM)
0422-0200	RH	15	5 x 2.5	20	6 x 3
0423-0200	LH	15	5 x 2.5	20	6 x 3
0424-0200	RH	15	5 x 2.5	25	8 x 3.5
0425-0200	LH	15	5 x 2.5	25	8 x 3.5
0426-0200	RH	15	5 x 2.5	30	8 x 3.5
0427-0200	LH	15	5 x 2.5	30	8 x 3.5

**NOTE: METRIC SIZES AVAILABLE ONLY IN HIGH TORQUE ROLLER BEARING MODELS.**

**NOTE:** FOR HIGH TORQUE ROLLER BEARING MODELS THE "A" BORE CONTAINS THE 15 TOOTH GEAR. THE "B" BORE CONTAINS THE 30 TOOTH GEAR.

# Float-A-Shaft Gearbox

## STANDARD SERIES - 2 1/2:1 RATIO - US

### AVAILABLE STYLES

#### Low Torque Journal Bearings

##### Standard

3-1/2 lbs. (1.59 kgs.)



### DIMENSIONS: STANDARD LOW TORQUE BEARINGS

Model Builder 3D CAD Available at: [www.tolomatic.com](http://www.tolomatic.com)

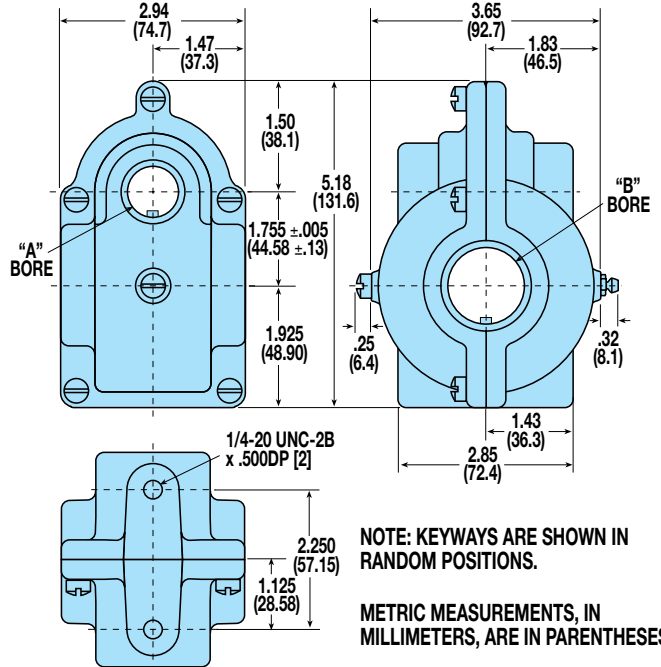

NOTE: KEYWAYS ARE SHOWN IN RANDOM POSITIONS.

METRIC MEASUREMENTS, IN MILLIMETERS, ARE IN PARENTHESES

### PERFORMANCE DATA

#### Low Torque Journal Bearings

#### Torque and Efficiency vs RPM at Maximum Bearing Temperature

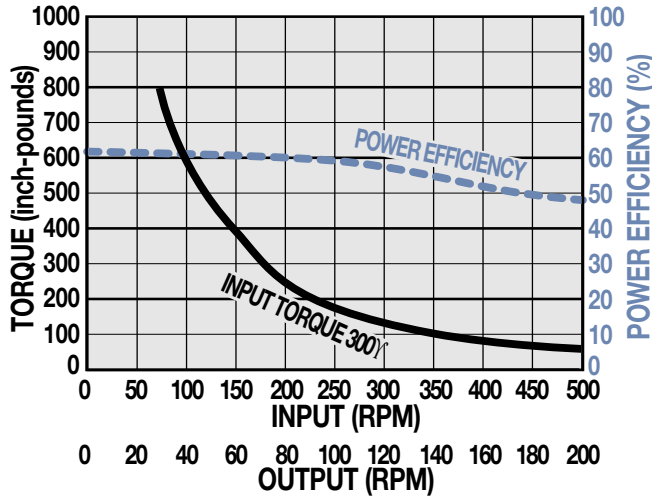

### Models and Bore Dimensions

#### U.S. - STANDARD - 2 1/2:1 LOW TORQUE JOURNAL BEARING

LOW TORQUE JOURNAL MODEL NO.	RH OR LH	"A" BORE		"B" BORE	
		BORE SIZE (IN.)	WXD KEYWAY (IN.)	BORE SIZE (IN.)	WXD KEYWAY (IN.)
0403-0000	LH	1/2	1/8 x 1/16	3/4	3/16 x 3/32
0404-0000	RH	1/2	1/8 x 1/16	3/4	3/16 x 3/32
0407-0000	LH	1/2	1/8 x 1/16	1	1/4 x 1/8
0408-0000	RH	1/2	1/8 x 1/16	1	1/4 x 1/8
0411-0000	LH	1/2	1/8 x 1/16	1-1/4	1/4 x 1/8
0412-0000	RH	1/2	1/8 x 1/16	1-1/4	1/4 x 1/8
0417-0000	LH	5/8	1/8 x 1/16	3/4	3/16 x 3/32
0418-0000	RH	5/8	1/8 x 1/16	3/4	3/16 x 3/32
0421-0000	LH	5/8	1/8 x 1/16	1	1/4 x 1/8
0422-0000	RH	5/8	1/8 x 1/16	1	1/4 x 1/8
0425-0000	LH	5/8	1/8 x 1/16	1-1/4	1/4 x 1/8
0426-0000	RH	5/8	1/8 x 1/16	1-1/4	1/4 x 1/8

NOTE: THE "A" BORE CONTAINS THE 10 TOOTH GEAR. THE "B" BORE CONTAINS THE 25 TOOTH GEAR.

- SLIDE-RITE GEARBOX
- ENDURANCE TECHNOLOGY
- APPLICATION EXAMPLE
- COMPACT SERIES 1:1 RATIO
- STANDARD SERIES 1:1 RATIO
- STANDARD SERIES 3:2 RATIO
- STANDARD SERIES 2:1 RATIO
- FLOAT-A-SHAFT
- APPLICATIONS
- INTRODUCTION
- COMPACT SERIES 1:1 RATIO
- STANDARD SERIES 1:1 RATIO
- STANDARD SERIES 3:2 RATIO
- STANDARD SERIES 2:1 RATIO
- STANDARD SERIES 2.5:1 RATIO
- SELECTION
- INSTALLATION
- SHAFT & KEYWAY REQUIREMENTS

# SELECTION

## 1.) DETERMINE INPUT TORQUE AND RPM REQUIRED

To select the Slide-Rite®, Slide-Rite®CR Gearbox, or Float-A-Shaft gearbox required for your application, you must determine the input torque and RPM required for your application. The maximum RPM rating for the Float-A-Shaft is 500 RPM, for the Slide-Rite® and the Slide-Rite®CR Gearbox it's 1200 RPM.

## 2.) NEED A GEAR RATIO OTHER THAN 1:1?

When utilizing the Float-A-Shaft ratioed units, the highest RPM shaft speed on either the input or the output shaft should not exceed 500 RPM. For the Slide-Rite ratioed units, the shaft speed (input or output) should not exceed 1200 RPM.

## 3.) REFER TO THE CATALOG PAGE FOR THE RATIO YOU HAVE SELECTED

Find your input torque in inch-pounds for the selected gearbox unit on the graph and intersect it with the RPM of the input shaft. In general, gearbox capacity increases as listed below:

- 1.) Float-A-Shaft: Compact: Low Torque Journal Bearings
- 2.) Float-A-Shaft: Compact: High Torque Roller Bearings
- 3.) Slide-Rite CR: Compact
- 4.) Float-A-Shaft: Standard: Low Torque Journal Bearings
- 5.) Slide-Rite: Compact
- 6.) Slide-Rite CR: Standard
- 7.) Float-A-Shaft: Standard: High Torque Roller Bearings
- 8.) Slide-Rite: Standard

For ratios other than 1:1 refer to the performance graph for that Float-A-Shaft gearbox. When torque vs RPM intersects below the 300°F curve, you have selected a gearbox suitable for your application.

If your torque vs RPM intersection point is above the 300°F curve, then you do not have a proper application for that gearbox. Your options are to reduce either your input torque or RPM to get under the 300°F curve or try a gearbox with greater capacity.

## 4.) SELECT PROPER BORE SIZE

After gearbox series selection, choose the bore size that suits your shaft requirements. (NOTE: Float-A-Shaft high torque roller bearing models and Slide-Rite 1:1 ratio models are available in metric sizes also.)

## 5.) DETERMINE YOUR OUTPUT TORQUE

## SLIDE-RITE™ & SLIDE-RITE™CR SELECTION EXAMPLE

Example: Slide-Rite® Gearbox Standard Series at 700 RPM and 90 inch-pounds of input torque (Refer to the graph shown below. From page 5)

Output torque = (Input torque) (efficiency) (ratio)  
 Output torque = (90 in.-lbs.) (.88) (1:1)  
 Output torque = 79 in.-lbs.

### PERFORMANCE DATA High Torque Ball Bearings Torque and Efficiency vs RPM at Maximum Bearing Temperature

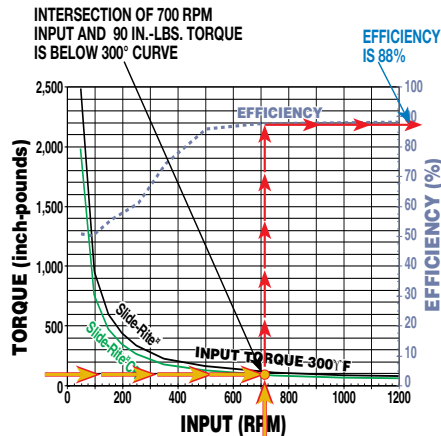

## FLOAT-A-SHAFT SELECTION EXAMPLE

Multiply the input torque by the gearbox's efficiency times the gear ratio. See examples:

Example: 3:2 Ratio Journal Bearing Float-A-Shaft at 50 RPM and 500 inch-pounds of input torque (See graph below. From page 16)

Output torque = (Input torque) (efficiency) (ratio)  
 Output torque = (500 in.-lbs.) (.62) (3:2)  
 Output torque = 465 in.-lbs.

### STANDARD SERIES 3:2 RATIO

### PERFORMANCE DATA Low Torque Journal Bearings Torque and Efficiency vs RPM at Maximum Bearing Temperature

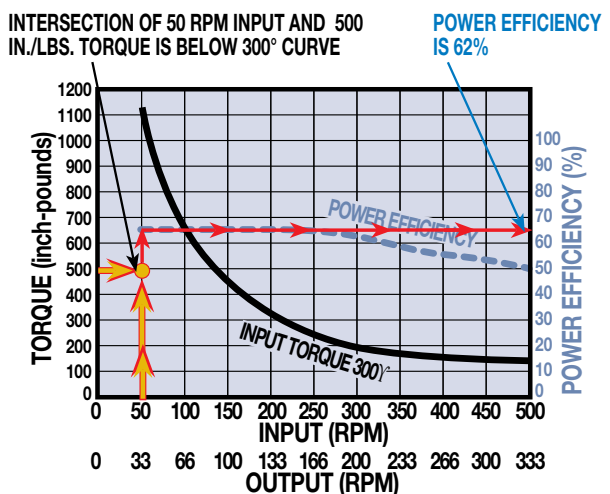



# Gearbox

## INSTALLATION



A plastic or cardboard dowel is inserted through the shaft bores during assembly and shipped in place. It allows you to install the Slide-Rite®, Slide-Rite®CR Gearbox, or Float-A-Shaft gearbox on your shafts in less than a minute.

To install your gearbox, simply line up the keyway on your shaft with the key and bore of the gearbox. Push the shaft through into place! The dowel falls out the other side and can be thrown away.

Gearboxes need not be disassembled and reassembled during installation. The dowel holds the gears in perfect alignment during installation and protects the precision internal parts from contamination and damage during shipping.

This fast and easy method of installation can be used whenever the keyways on your shafts extend out to the end of the shafts. For shafts with shorter keyways, the Float-A-Shaft can be built around the shaft. (Slide-Rite® and Slide-Rite®CR gearboxes cannot be disassembled.)

### Rotation of left hand and right hand drive compared, Slide-Rite® gearbox shown

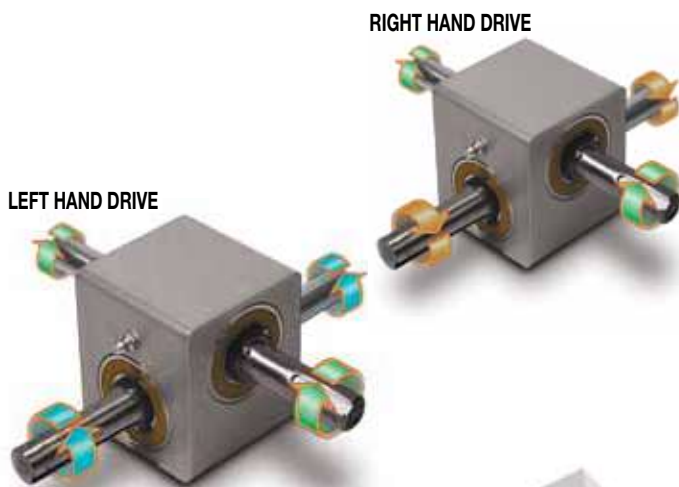

This bottle capping application utilizes both left hand and right hand gearboxes

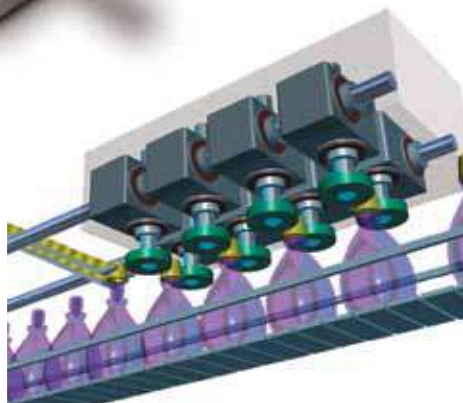

## SHAFT & KEYWAY REQUIREMENTS

### Shaft Diameter

Tolerance of plus 0.000 in. to minus 0.002 in. is recommended and should have runout within 0.002 in. TIR.

### Shaft Material

Use only alloy steel or stainless-steel for shafting, having a minimum hardness of RC40, or transmission shafting grade like 4140 or equivalent.

### Shaft Finish

In stationary applications the shaft finish should be 64 RMS or better. Shaft finish for traversing applications should be 32 RMS.

### Shaft Straightness

Shaft should be straight within 0.0015 in. TIR. per foot.

### Keyway

Keyway should be made up to 0.001 oversize than the nominal. See dimension table for nominal keyway sizes. Sharp edges of keyway should be avoided.

### Shaft Support

The shafts should be supported rigidly with either bearing blocks or pillow blocks to avoid excessive deflection. Gearbox bearings are designed to support the internal thrust and radial loads generated by the gear teeth. Shaft support should be located as close to the gearbox body as the application will allow. Supports greater than 25" from gearbox body (20" for compact models) can reduce gearbox efficiency and, ultimately, its life.

### Lubrication, all gearboxes

An extreme-pressure synthetic lubricant which exhibits excellent anti-wear and rust protection qualities such as Mobilith® SHC 460 [14 oz. cartridge #0100-1605] or equivalent is recommended.

Temperature range .....	0 - 300°F
NLGI Number .....	1.5 - 2
Dropping Point (ASTM D566) .....	490+
Penetration Worked (ASTM D217) .....	300

Slide-Rite® Gearbox is a registered trademark of Tolomatic, Inc.

Mobilith® SHC 460 is a registered trademark of Exxon Mobil Corporation, [www.mobil.com](http://www.mobil.com)

### Lubrication, Slide-Rite® gearboxes

The Slide-Rite® Gearbox is lubricated at the factory and is ready for installation. **For most applications the unit is greased for life.** (See the Slide-Rite Gearbox service sheet [#0100-4002 at [tolomatic.com](http://tolomatic.com)] for lubrication guidelines.)



## **CALIPER DISC BRAKES**

### ***Pneumatic Brakes***

Pages 32 through 37

### ***Spring Applied Brakes***

Pages 66 through 79

### ***Hydraulic Brakes***

Pages 38 through 49

### ***Discs, Hubs and Bushings***

Pages 80 through 87

### ***Hydraulic/Mechanical Brakes***

Pages 50 through 55

### ***Tension Control Combinations***

Page 88

### ***Mechanical Brakes***

Pages 56 through 65

Visit [www.tolomatic.com](http://www.tolomatic.com) for the latest updates and ordering.

FEATURES

APPLICATIONS

SELECTION  
GRAPHS

PNEUMATIC  
BRAKES

P10

P20

P220

HYDRAULIC  
BRAKES

H10

H20

H220

H220I

H441

H960

HYDRAULIC/  
MECHANICAL  
BRAKE  
COMBOS

H/ME20

H/ME220

MECHANICAL  
BRAKES

ME10

ME20

ME220

MB3

SPRING  
APPLIED  
BRAKES

FS20

FS220

FS220I

FS595

DISCS  
HUBS &  
BUSHINGS

TENSION  
CONTROL  
COMBINATIONS

INTENSIFIER

SELECTION

WORKSHEET

## FEATURES

FEATURES

APPLICATIONS

SELECTION  
GRAPHS

PNEUMATIC  
BRAKES

P10

P20

P220

HYDRAULIC  
BRAKES

H10

H20

H220

H220I

H441

H960

HYDRAULIC/  
MECHANICAL  
BRAKE  
COMBOS

H/ME20

H/ME220

MECHANICAL  
BRAKES

ME10

ME20

ME220

MB3

SPRING  
APPLIED  
BRAKES

FS20

FS220

FS220I

FS595

DISCS  
HUBS &  
BUSHINGS

TENSION  
CONTROL  
COMBINATIONS

INTENSIFIER

SELECTION

WORKSHEET

### PNEUMATIC BRAKES

REPLACEABLE HIGH-GRADE  
FRICTION MATERIAL

STANDARD  
BUNA-N SEALS

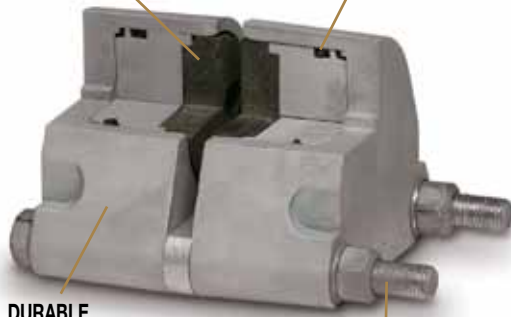

DURABLE  
CONSTRUCTION

PLATED BOLTS

Tolomatic manufactures pneumatic brakes in three sizes: P10 Series, P20 Series and P220 Series. Available in both double acting or single acting. These brakes feature replaceable, high-grade friction material, standard Buna-N seals, aluminum construction and zinc plated bolts. Options include EPR seals, Viton® seals, retractable pistons and floating bracket. (See pages 32 to 37)

### HYDRAULIC BRAKES

STANDARD  
BUNA-N SEALS

REPLACEABLE HIGH-GRADE  
FRICTION MATERIAL

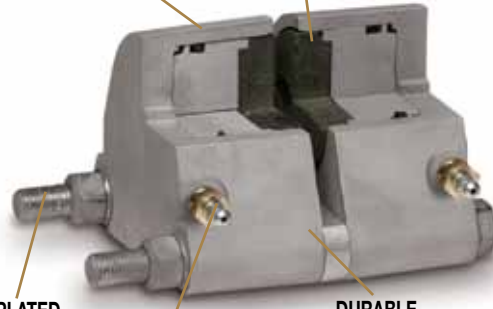

PLATED  
BOLTS

BLEEDER SCREWS

DURABLE  
CONSTRUCTION

Tolomatic hydraulic caliper disc brakes are available in the widest range of sizes. From the H10 Series up to the H960 Series, these brakes are sure to supply the braking torque you need for your application. Available in both double acting or single acting (depending on model). These brakes feature replaceable, high-grade friction material, standard Buna-N seals, aluminum or cast iron construction (depending on model), bleeder screws and zinc plated bolts. Options include EPR seals, Viton® seals, retractable pistons and floating brackets. (See pages 38 to 49)

### HYDRAULIC / MECHANICAL BRAKES

MACHINED OR  
STAMPED LEVER/CAM

STANDARD  
EPR SEALS

REPLACEABLE  
HIGH-GRADE  
FRICTION  
MATERIAL

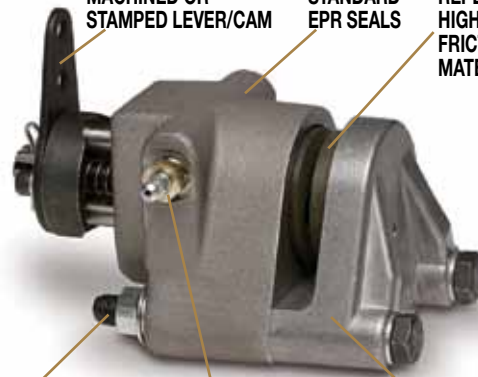

PLATED  
BOLTS

BLEEDER  
SCREWS

DURABLE  
CONSTRUCTION

These Tolomatic brakes combine hydraulic and mechanical braking in one caliper. Available in the H/ME20 Series and H/ME220 Series these single acting calipers deliver high braking torque in a small package. Features include: replaceable, high-grade friction material, standard EPR seals, aluminum or cast iron construction (depending on model), bleeder screws and zinc plated bolts. Options include Buna-N seals, Viton® seals and floating brackets. (See pages 50 to 55)

## FEATURES

### MECHANICAL BRAKES

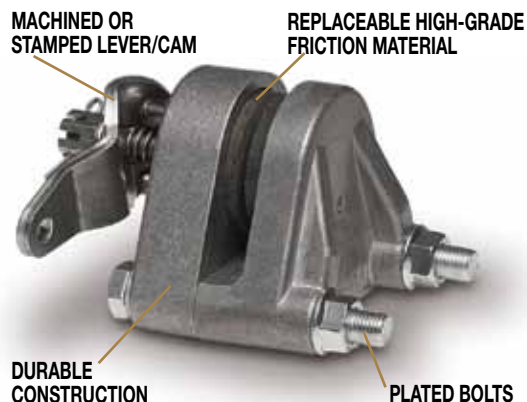

Tolomatic manufactures a broad range of mechanical brakes in these series: ME10, ME20, ME220 and MB3. Designed for use in areas that do not have access to other types of power, these single acting calipers feature replaceable, high-grade friction material, aluminum or cast iron construction (depending on model) and zinc plated bolts. (See pages 56 to 65)

### SPRING APPLIED BRAKES

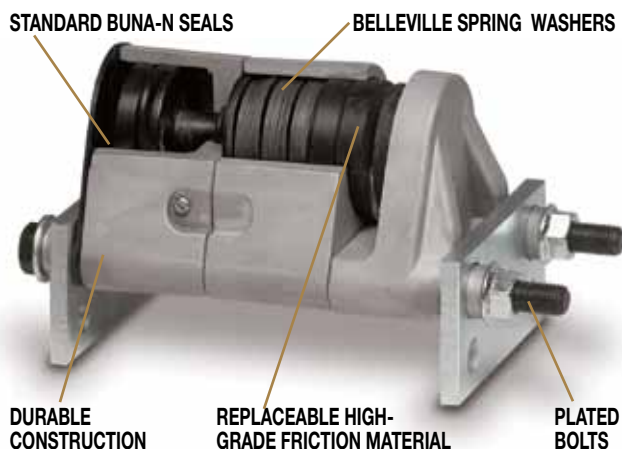

Tolomatic offers spring applied brakes in sizes ranging from FS20 Series to FS595 Series. These brakes require pressure (normally hydraulic) for disc release. Braking force is provided by a stack (or stacks) of Belleville spring washers. The concave washers are capable of storing enormous force. When the brake is pressurized a piston(s) moves to compress the spring washer stack(s), thus releasing the disc. These calipers feature replaceable, high-grade friction material, aluminum or cast iron construction (depending on model), Buna-N seals and zinc plated bolts. Options include EPR seals, retractable pistons and manual compensators. (See pages 66 to 79)

### DISC AND HUBS

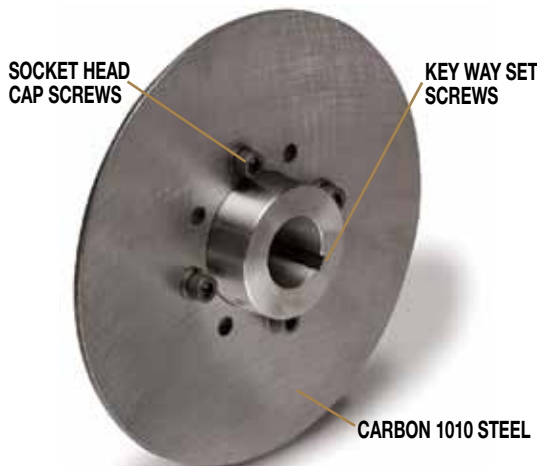

Tolomatic offers several discs and hubs to fit your application. Most are made of carbon 1010 steel, are flat within .010 inch, stress relieved and blanchard ground to an 80 (RMS) microinch finish. Discs also feature socket head cap screw fasteners and key way set screws. Standard disc diameters are 6-5/16, 8, 10, 12 and 16 inches. Disc thicknesses range from 5/32" to 1/2". Available: Fixed Hub and Disc Assemblies, Fixed Hub and Disc Assemblies with Q.D. Bushings, Q.D. Bushings and Hubs, One-Piece Hub and Disc, Blank Disc, Disc with Bolt Circles and Pilot Holes, and Ventilated Disc. (See pages 80 to 87)

Viton® is a registered trademark of the E.I. Du Pont de Nemours Co., [www.dupont.com](http://www.dupont.com)



## APPLICATIONS

### CONVEYOR BELT EMERGENCY BRAKE

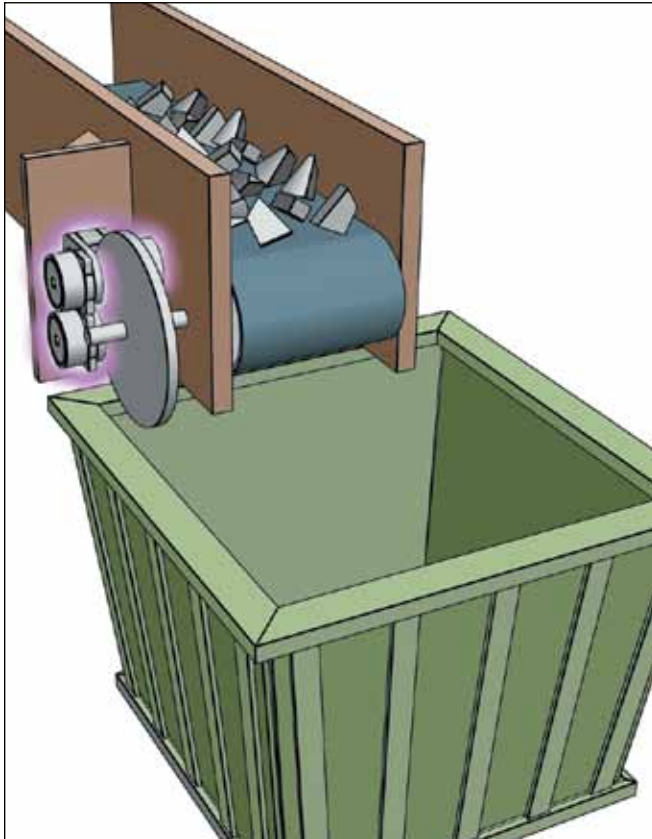

Tolomatic caliper disc brakes find uses in industrial settings all over the world. Used on everything from assembly lines to wind generators and lawn maintenance equipment, Tolomatic calipers offer the braking capacity you need at an economical price. The variety of sizes, maximum torque output and thermal capabilities insure you will find the optimal brake for your application. These illustrations are meant to help you to see ways that our calipers will work for you. Above a Spring Applied Brake is used on a conveyor belt. In this application it will provide braking when hydraulic pressure is *Not* provided to the brake. This type of braking is especially useful in situations where safety is an issue. Since a Spring Applied Brake requires hydraulic pressure to *Release* the brake, in a power shut down these brakes will engage providing positive braking.

### TENSIONING APPLICATION

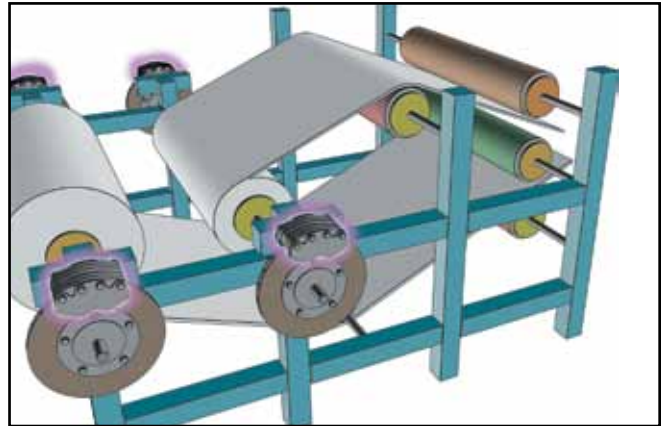

Another great place for Tolomatic brakes is tensioning/constant slip applications. Used in everything from mylar balloon fabrication to web presses, Tolomatic pneumatic brakes provide dynamic tensioning that is adjusted by the air pressure supplied to the caliper. Because of the constant nature of this type of braking, caliper and disc are sized on thermal characteristics rather than torque.

### MACHINE COMPONENTS

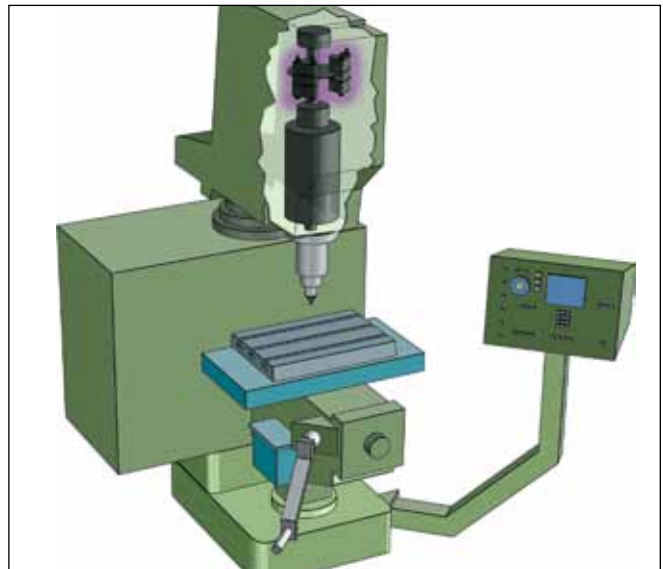

Here two Tolomatic pneumatic brakes are used to increase the productivity of a CNC milling machine. In the original design users had to wait for the machine to coast to a stop before a part could be removed or a tool changed. Electronic deceleration proved to be expensive and harmful to the motor. Tolomatic caliper disc brakes improved stopping time by 500 percent, increasing the machine's productivity and safety.



## SELECTION GRAPH & TABLE

### DYNAMIC TORQUE - PNEUMATIC, HYDRAULIC

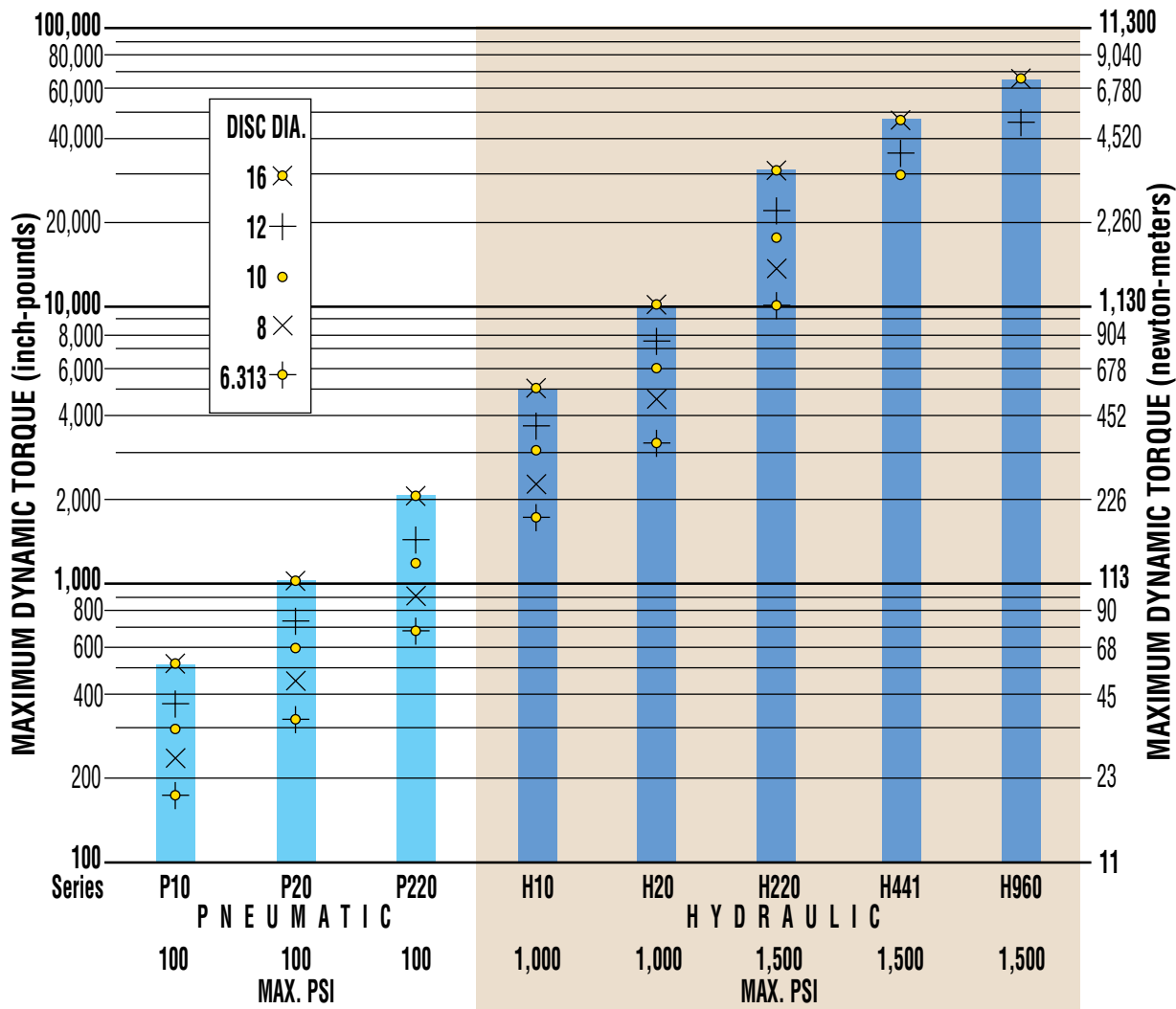

The table below includes the same information as the graph above (adding discs not sold by Tolomatic) with the maximum dynamic torque [inch-pounds] for each series brake using the disc size in left column and PSI at the bottom of the table.

Disc Dia.	P10	P20	P220	H10	H20	H220	H441	H960
6.313	174	328	685	1,737	3,285	10,282		
8	233	450	907	2,328	4,500	13,608		
10	303	594	1,184	3,028	5,940	17,755	19,539	
12	373	738	1,463	3,728	7,380	21,946	24,834	45,672
14	443	882	1,771	4,428	8,820	26,568	30,129	56,052
16	513	1,026	2,076	5,128	10,260	31,147	35,424	66,432
18							40,719	76,812
20							46,014	
22							51,309	
24							56,606	
	100	100	100	1,000	1,000	1,500	1,500	1,500
	PNEUMATIC			HYDRAULIC				

NOTE: GREY BACKGROUND INDICATES DISC SIZES NOT AVAILABLE FROM TOLONATIC.

**Note: Selection instructions and formulae begin on page 89 of this catalog. Please refer to these instructions or call 1-800-328-2174 for assistance.**

## SELECTION GRAPH & TABLE

### STATIC TORQUE - PNEUMATIC, HYDRAULIC, MECHANICAL

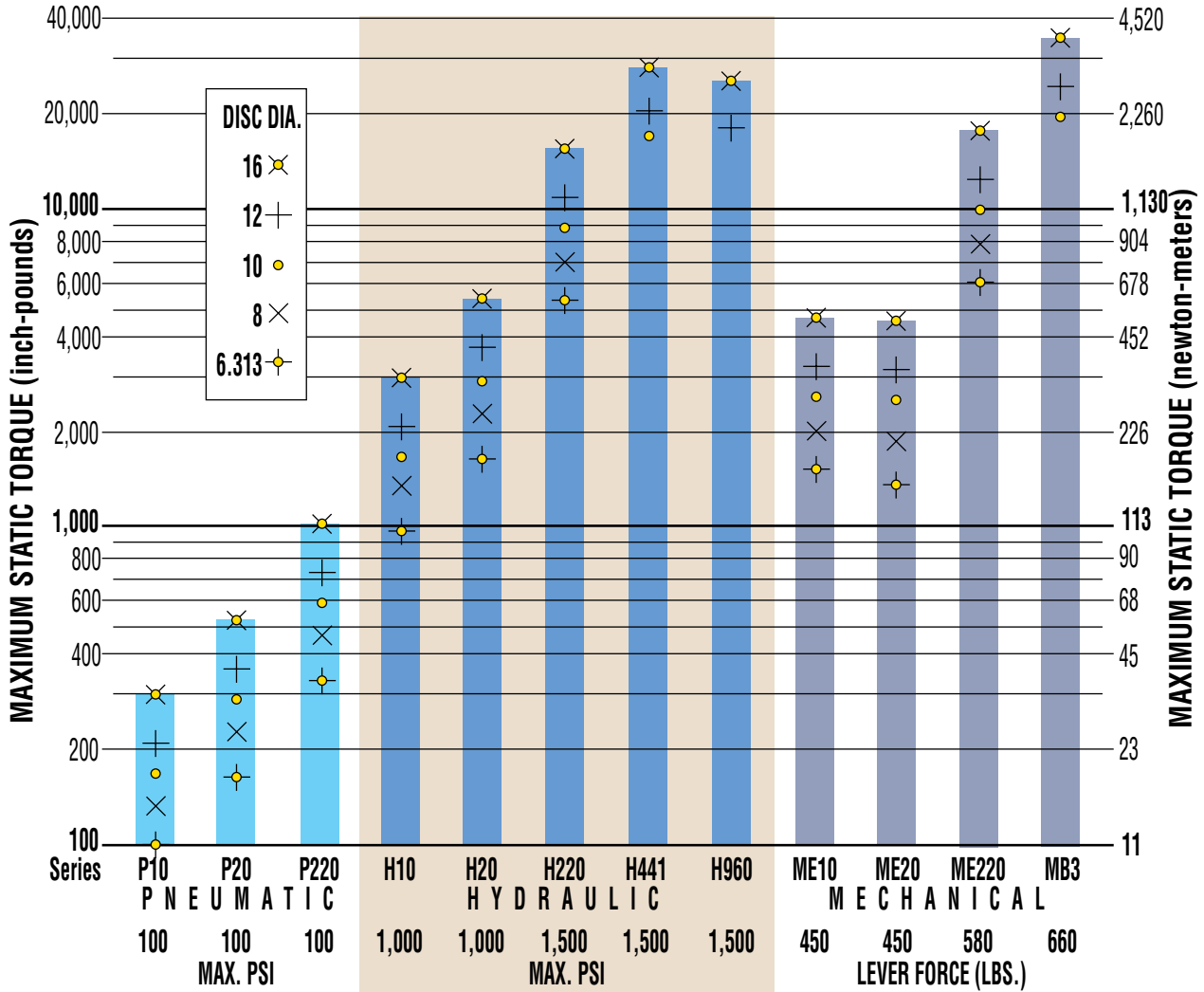

The table below includes the same information as the graph above (adding discs not sold by Tolomatic) with the maximum static torque [inch-pounds] for each series brake using the disc size in left column and PSI (or Lever Force) at the bottom of the table.

Disc Dia.	P10	P20	P220	H10	H20	H220	H441	H960	ME10	ME20	ME220	MB3	
6.313	99	164	343	993	1,642	5,141			1,502	1,381	5,851		
8	133	225	454	1,330	2,250	6,804			2,012	1,891	7,744		
10	173	297	592	1,730	2,970	8,878	11,679		2,618	2,497	10,104	19,893	
12	213	369	732	2,130	3,690	10,973	14,844	26,664	3,223	3,102	12,489	24,506	
14	253	441	886	2,530	4,410	13,284	18,009	32,724	3,828	3,707	15,120	29,120	
16	293	513	1,038	2,930	5,130	15,574	21,174	38,784	4,433	4,312	17,726	33,733	
18							24,339	44,844				38,347	
20							27,504					42,960	
22							30,669					47,573	
24							33,834					52,187	
26												56,800	
28												61,414	
30												66,027	
	100	100	100	1,000	1,000	1,500	1,500	1,500	450	450	580	660	
	PNEUMATIC			HYDRAULIC			MECHANICAL						

NOTE: GREY BACKGROUND INDICATES DISC SIZES NOT AVAILABLE FROM TOLONATIC.

## SELECTION GRAPH & TABLE

### STATIC TORQUE - SPRING APPLIED

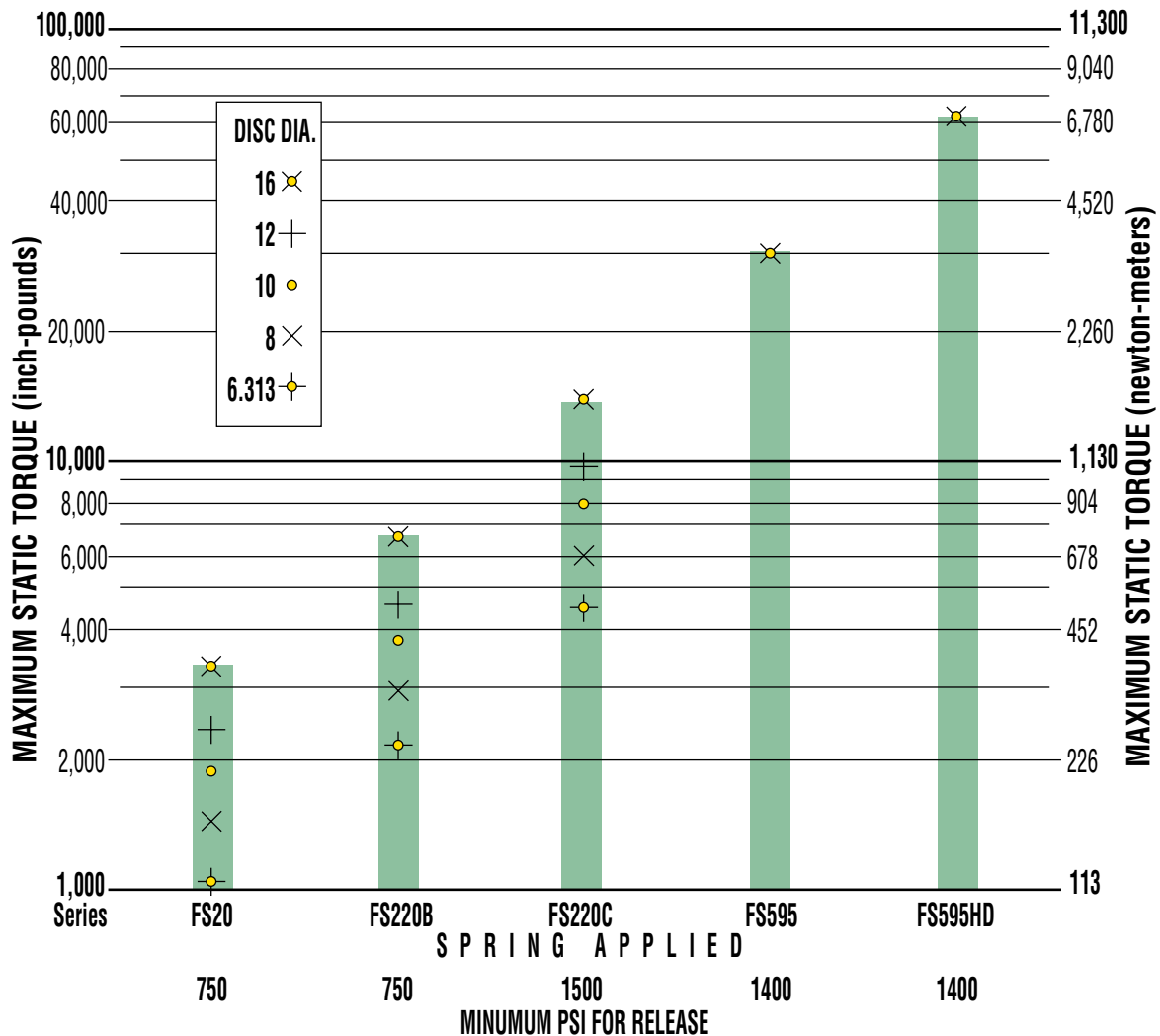

The table below includes the same information as the graph above (adding discs not sold by Tolomatic) with the maximum static torque [inch-pounds] for each series brake using the disc size in left column and release pressure (PSI) at the bottom of the table.

Disc Dia.	FS20	FS220B	FS220C	FS595	FS595 Dual
6.313	1,061	2,213	4,522		
8	1,453	2,930	5,985		
10	1,918	3,822	7,809		
12	2,383	4,724	9,652		
14	2,848	5,715	11,676	26,426	52,853
16	3,313	6,705	13,699	31,046	62,093
18				35,666	71,333
20				40,286	80,573
22				44,906	89,813
24				49,526	99,053
26				54,146	108,293
28				58,766	117,533
30				63,386	126,733
	750	750	1500	1400	1400

**Note: Selection instructions and formulae begin on page 89 of this catalog. Please refer to these instructions or call 1-800-328-2174 for assistance.**

NOTE: GREY BACKGROUND INDICATES DISC SIZES NOT AVAILABLE FROM TOLOMATIC.

## P10 SERIES - ALUMINUM

### AVAILABLE STYLES

#### Double Acting

FIXED MOUNT - FIXED DISC



PICTURED: 0701-0000

#### Single Acting

FIXED MOUNT - FLOATING DISC



PICTURED: 0705-0000

#### Single Acting with Floating Bracket

FLOATING MOUNT - FIXED DISC



PICTURED:  
0705-0001

### P10 SPECIFICATIONS

Maximum Pressure Rating:	100 PSI
Accommodates Tolomatic disc diameters:	6-5/16", 8", 10", 12", 16"
Maximum disc diameter:	none
Housing Material:	Extruded aluminum
Bolts:	Zinc plated grade 5
Seals:	Buna-N Standard
Wearable friction material:	0.47 in <sup>3</sup>
Wearable friction material/retractable models:	0.13 in <sup>3</sup>
Friction material:	Replaceable, high-grade
Total lining area:	1.84 in <sup>2</sup>
Total lining area/retractable models:	1.64 in <sup>2</sup>
Piston diameter:	1.125 in.
Fluid displacement, non-retractable:	Single acting = 0.029 in <sup>3</sup> Double acting = 0.029 in <sup>3</sup>

#### OPTIONS

Seals:	EPR seals
Pistons:	Retractable piston(s)
Floating bracket:	Stamped steel construction

### PERFORMANCE DATA

#### Dynamic Torque vs Pressure

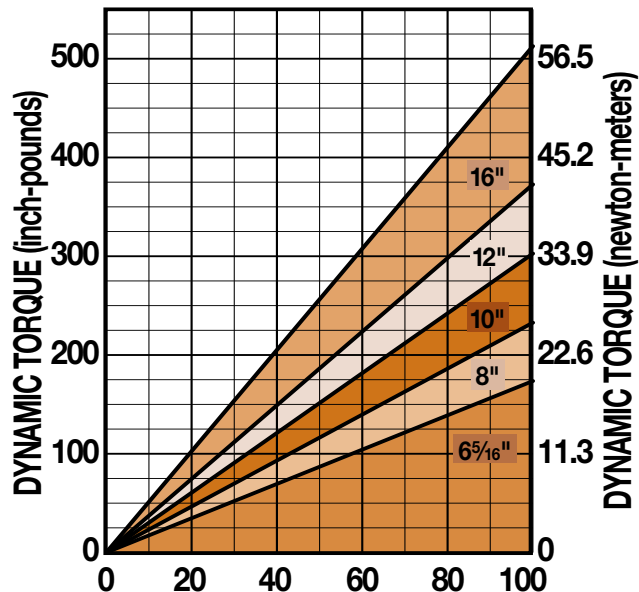

#### Static Torque vs Pressure

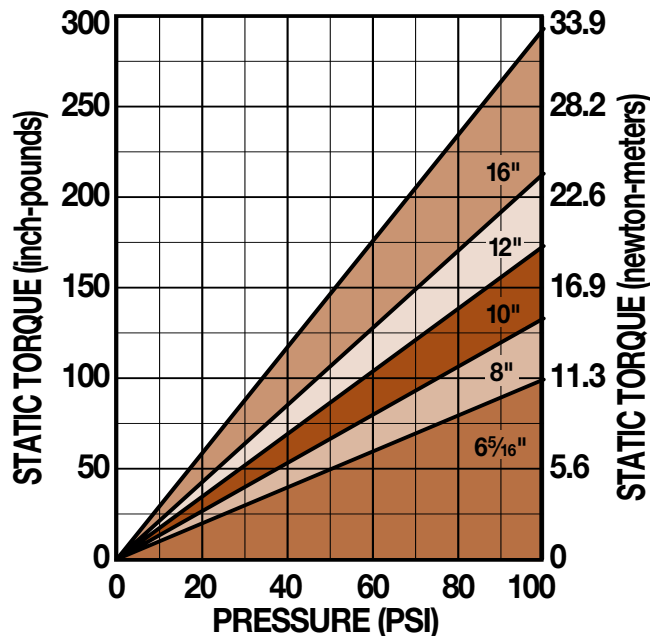

### DISC SIZING EQUATIONS

**DYNAMIC TORQUE (IN.-LBS.) = 0.70 x BRAKING RADIUS (IN.) x PRESSURE (PSI)**  
**STATIC (PARKING) TORQUE (IN.-LBS.) = 0.40 x BRAKING RADIUS (IN.) x PRESSURE (PSI)**  
**BRAKING RADIUS (IN.) = [DISC DIAMETER ÷ 2] - 0.624**



## P10 SERIES - ALUMINUM

### DOUBLE ACTING

FIXED MOUNT - FIXED DISC

Accommodates disc thickness: 5/32" 1/4" 3/8" 1/2"

Weight 1.0 lbs. .45 kgs.

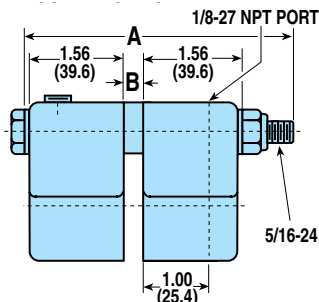

MODEL CODE	DISC THK.	A	B	OPTIONS / DESCRIPTION	ASSEMBLY NUMBER
P10DA	5/32"	3.50"	.281"	Double Acting	0701-0000
P10DAR	5/32"	3.50"	.281"	Double Acting, Retractable Pistons	0708-0000
P10DB	1/4"	3.50"	.375"	Double Acting	0702-0000
P10DBR	1/4"	3.50"	.375"	Double Acting, Retractable Pistons	0709-0000
P10DER	1/2"	4.00"	.625"	Double Acting, Retractable Pistons	0709-0003
P10DL	3/8"	4.00"	.500"	Double Acting	0702-0002
P10DLR	3/8"	4.00"	.500"	Double Acting, Retractable Pistons	0709-0002

### SINGLE ACTING

FIXED MOUNT - FLOATING DISC

Accommodates disc thickness: 5/32" 1/4"

Weight .75 lbs. .34 kgs.

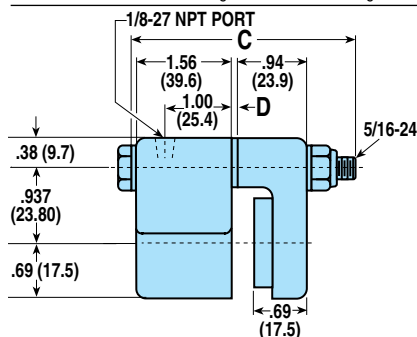

MODEL CODE	DISC THK.	C	D	OPTIONS / DESCRIPTION	ASSEMBLY NUMBER
P10SA	5/32"	3.00"	—	Single Acting	0705-0000
P10SB	1/4"	3.00"	.094"	Single Acting	0703-0000

### SINGLE ACTING WITH FLOATING BRACKET

FLOATING MOUNT - FIXED DISC

Accommodates disc thickness: 5/32" 1/4"

Weight 1.5 lbs. .68 kgs.

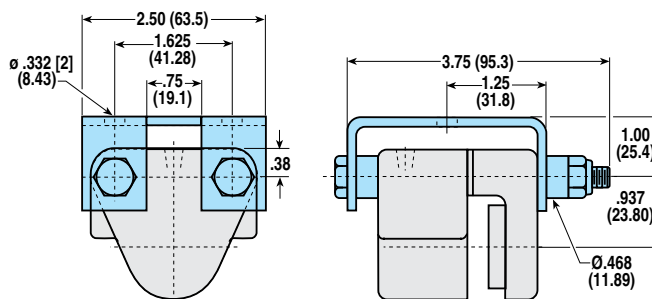

See SINGLE ACTING dimensional drawing for additional measurements

MODEL CODE	DISC THK.	C	D	OPTIONS / DESCRIPTION	ASSEMBLY NUMBER
P10SAF	5/32"	3.00"	—	Single Acting, Floating Bracket	0705-0001
P10SBF	1/4"	3.00"	.094"	Single Acting, Floating Bracket	0703-0001

### MOUNTING DIMENSIONS

Disc Diameter	E	6.313"	8"	10"	12"	16"
	F	3.469"	4.313"	5.313"	6.313"	8.313"
Braking Radius	G	2.532"	3.376"	4.376"	5.376"	7.376"

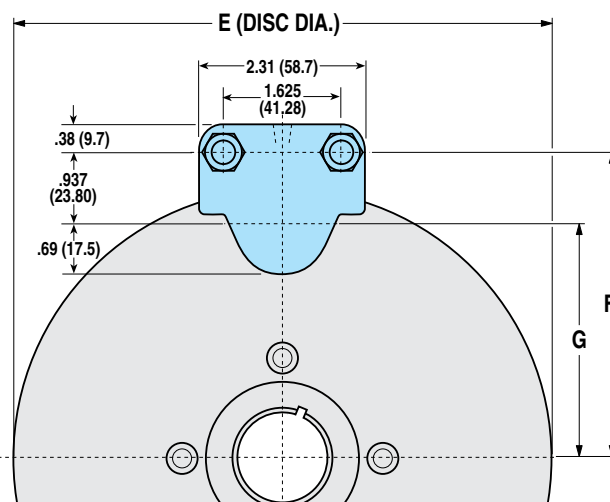

### BRAKE MODEL LETTER CODES

<b>A</b> 5/32" Thick Disc	<b>E</b> 1/2" Thick Disc	<b>P</b> Pneumatic Brake
<b>B</b> 1/4" Thick Disc	<b>F</b> Floating Bracket Mount	<b>R</b> Retractable Piston(s)
<b>D</b> Double Acting	<b>L</b> 3/8" Thick Disc	<b>S</b> Single Acting

CALIPER  
DISC  
BRAKES

FEATURES

APPLICATIONS

SELECTION  
GRAPHS

PNEUMATIC  
BRAKES

P10

P20

P220

HYDRAULIC  
BRAKES

H10

H20

H220

H220I

H441

H960

HYDRAULIC/  
MECHANICAL  
BRAKE  
COMBOS

H/ME20

H/ME220

MECHANICAL  
BRAKES

ME10

ME20

ME220

MB3

SPRING  
APPLIED  
BRAKES

FS20

FS220

FS220I

FS595

DISCS  
HUBS &  
BUSHINGS

TENSION  
CONTROL  
COMBINATIONS

INTENSIFIER

SELECTION

WORKSHEET

## P20 SERIES - ALUMINUM

### AVAILABLE STYLES

#### Double Acting

FIXED MOUNT - FIXED DISC



PICTURED: 0720-0000

#### Single Acting

FIXED MOUNT - FLOATING DISC



PICTURED: 0724-0000

#### Single Acting with Floating Bracket

FLOATING MOUNT - FIXED DISC



PICTURED:  
0724-0001

### P20 SPECIFICATIONS

Maximum Pressure Rating: 100 PSI

Accommodates Tolomatic disc diameters: 6-5/16", 8", 10", 12", 16"

Maximum disc diameter: none

Housing Material: Extruded aluminum

Bolts: Zinc plated grade 8

Seals: Buna-N Standard

Wearable friction material: 0.8 in<sup>3</sup>

Wearable friction material/retractable models: 0.5 in<sup>3</sup>

Friction material: Replaceable, high-grade

Total lining area: 3.75 in<sup>2</sup>

Piston diameter: 1.625 in.

Fluid displacement, non-retractable: Single acting = 0.062 in<sup>3</sup>  
Double acting = 0.062 in<sup>3</sup>

#### OPTIONS

Seals: EPR seals

Pistons: Retractable piston(s)

Floating bracket: Stamped steel construction

### PERFORMANCE DATA

#### Dynamic Torque vs Pressure

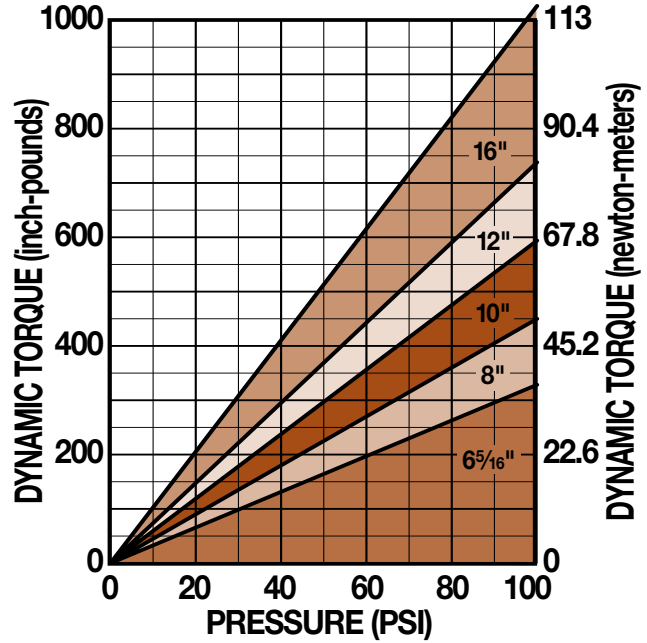

#### Static Torque vs Pressure

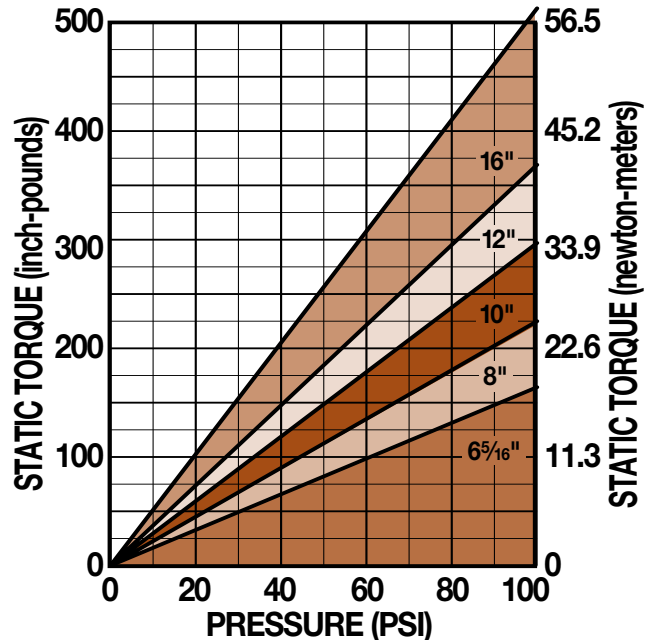

### DISC SIZING EQUATIONS

$$\text{DYNAMIC TORQUE (IN.-LBS.)} = 1.44 \times \text{BRAKING RADIUS (IN.)} \times \text{PRESSURE (PSI)}$$

$$\text{STATIC (PARKING) TORQUE (IN.-LBS.)} = 0.72 \times \text{BRAKING RADIUS (IN.)} \times \text{PRESSURE (PSI)}$$

$$\text{BRAKING RADIUS (IN.)} = [\text{DISC DIAMETER} \div 2] - 0.875$$

## P20 SERIES - ALUMINUM

### DOUBLE ACTING

FIXED MOUNT - FIXED DISC

Accommodates disc thickness: 5/32" 1/4" 3/8" 1/2"

Weight 2.0 lbs. .91 kgs.

1/8-27 NPT PORT

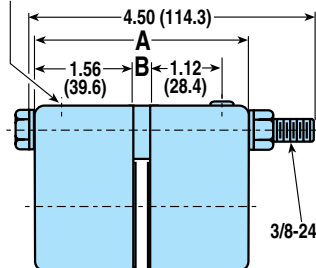

MODEL CODE	DISC THK.	A	B	OPTIONS / DESCRIPTION	ASSEMBLY NUMBER
P20DA	5/32"	3.41"	.281"	Double Acting	0720-0000
P20DAR	5/32"	3.41"	.281"	Double Acting, Retractable Pistons	0728-0000
P20DB	1/4"	3.50"	.375"	Double Acting	0721-0000
P20DBR	1/4"	3.50"	.375"	Double Acting, Retractable Pistons	0729-0000
P20DL	3/8"	3.62"	.500"	Double Acting	0720-0013
P20DLR	3/8"	3.62"	.500"	Double Acting, Retractable Pistons	0729-0001
P20DE	1/2"	3.75"	.625"	Double Acting	0725-0000
P20DER	1/2"	3.75"	.625"	Double Acting, Retractable Pistons	0719-0000

### SINGLE ACTING

FIXED MOUNT - FLOATING DISC

Accommodates disc thickness: 5/32" 1/4" 3/8"

Weight 1.5 lbs. .68 kgs.

1/8-27 NPT PORT

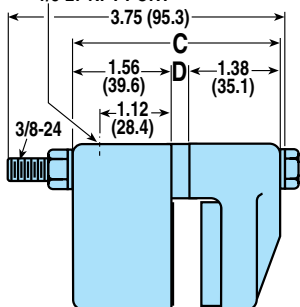

MODEL CODE	DISC THK.	C	D	OPTIONS / DESCRIPTION	ASSEMBLY NUMBER
P20SA	5/32"	2.94"	—	Single Acting	0724-0000
P20SB	1/4"	3.03"	.093"	Single Acting	0722-0000
P20SL	3/8"	3.16"	.219"	Single Acting	0722-0002

### SINGLE ACTING WITH FLOATING BRACKET

FLOATING MOUNT - FIXED DISC

Accommodates disc thickness: 5/32" 1/4"

Weight 2.0 lbs. .91 kgs.

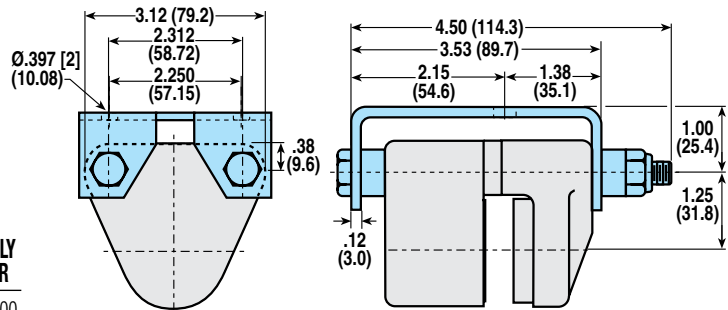

See SINGLE ACTING dimensional drawing for additional measurements

MODEL CODE	DISC THK.	C	D	OPTIONS / DESCRIPTION	ASSEMBLY NUMBER
P20SAF	5/32"	2.94"	—	Single Acting, Floating Bracket	0724-0001
P20SBF	1/4"	3.03"	.093"	Single Acting, Floating Bracket	0722-0001

### MOUNTING DIMENSIONS

Disc Diameter	E	6.313"	8"	10"	12"	16"
	F	3.531"	4.375"	5.375"	6.375"	8.375"
Braking Radius	G	2.281"	3.125"	4.125"	5.125"	7.125"

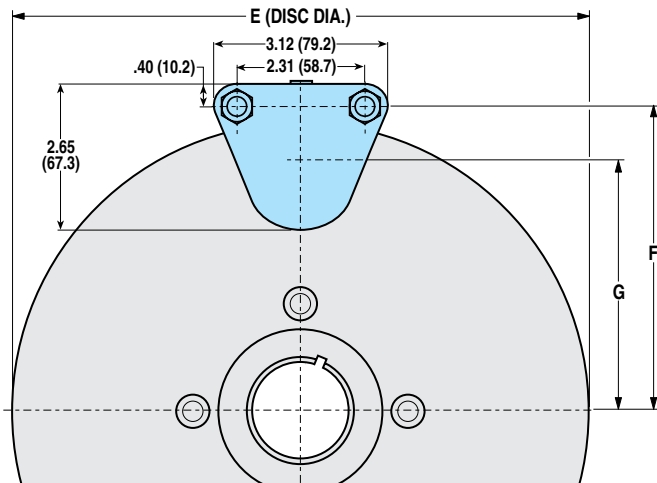

### BRAKE MODEL LETTER CODES

<b>A</b> 5/32" Thick Disc	<b>E</b> 1/2" Thick Disc	<b>P</b> Pneumatic Brake
<b>B</b> 1/4" Thick Disc	<b>F</b> Floating Bracket Mount	<b>R</b> Retractable Piston(s)
<b>D</b> Double Acting	<b>L</b> 3/8" Thick Disc	<b>S</b> Single Acting

CALIPER  
DISC  
BRAKES

FEATURES

APPLICATIONS

SELECTION  
GRAPHS

PNEUMATIC  
BRAKES

P10

P20

P220

HYDRAULIC  
BRAKES

H10

H20

H220

H220I

H441

H960

HYDRAULIC/  
MECHANICAL  
BRAKE  
COMBOS

H/ME20

H/ME220

MECHANICAL  
BRAKES

ME10

ME20

ME220

MB3

SPRING  
APPLIED  
BRAKES

FS20

FS220

FS220I

FS595

DISCS  
HUBS &  
BUSHINGS

TENSION  
CONTROL  
COMBINATIONS

INTENSIFIER

SELECTION

WORKSHEET

## P220 SERIES - ALUMINUM

### AVAILABLE STYLES

#### Double Acting

FIXED MOUNT - FIXED DISC



PICTURED: 0735-0100

#### Single Acting

FIXED MOUNT - FLOATING DISC



PICTURED: 0733-0000

#### Single Acting with Floating Bracket

FLOATING MOUNT - FIXED DISC



PICTURED:  
0733-0022

### P220 SPECIFICATIONS

Maximum Pressure Rating: 100 PSI

Accommodates Tolomatic disc diameters: 6-5/16", 8", 10", 12", 16"

Maximum disc diameter: 16"

Housing Material: Die cast aluminum

Bolts: Zinc plated grade 8

Seals: Buna-N Standard

Wearable friction material: 1.6 in<sup>3</sup>

Wearable friction material/retractable models: 1.0 in<sup>3</sup>

Friction material: Replaceable, high-grade

Total lining area: 7.5 in<sup>2</sup>

Piston diameter: 1.625 in.

Fluid displacement, non-retractable: Single acting = 0.124 in<sup>3</sup>  
Double acting = 0.124 in<sup>3</sup>

#### OPTIONS

Seals: EPR seals

Pistons: Retractable piston(s)

Floating bracket: Available

### PERFORMANCE DATA

#### Dynamic Torque vs Pressure

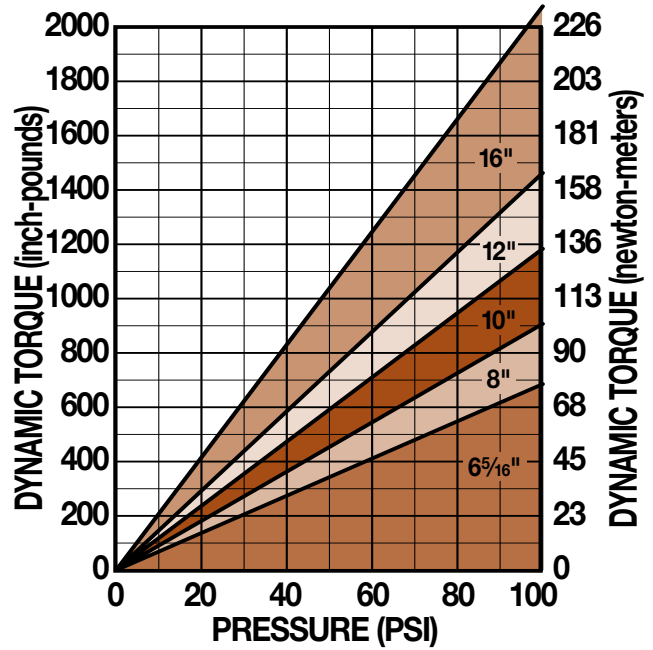

#### Static Torque vs Pressure

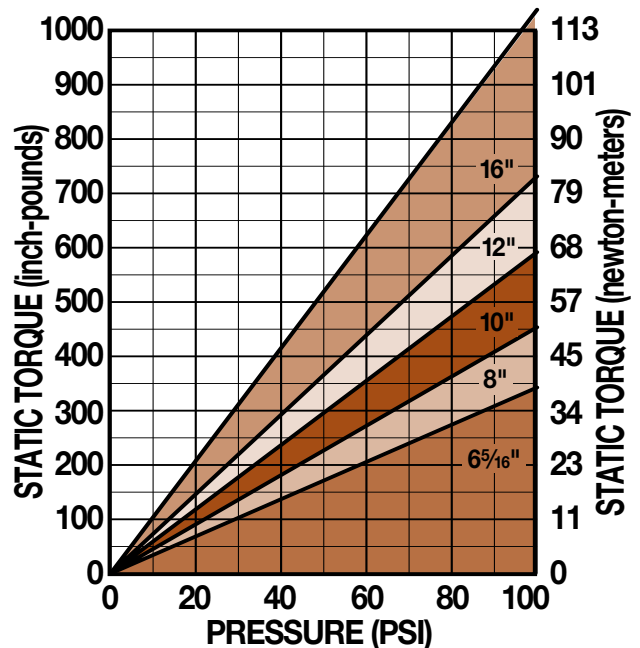

### DISC SIZING EQUATIONS

$$\text{DYNAMIC TORQUE (IN.-LBS.)} = 2.88 \times \text{BRAKING RADIUS (IN.)} \times \text{PRESSURE (PSI)}$$

$$\text{STATIC (PARKING) TORQUE (IN.-LBS.)} = 1.44 \times \text{BRAKING RADIUS (IN.)} \times \text{PRESSURE (PSI)}$$



## P220 SERIES - ALUMINUM

### DOUBLE ACTING

FIXED MOUNT - FIXED DISC

Accommodates disc thickness: 5/32" 1/4" 1/2"

Weight 4.0 lbs. 1.82 kgs.

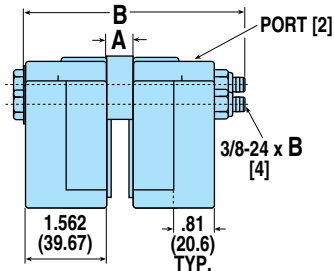

MODEL CODE	DISC THK.	A	B	OPTIONS / DESCRIPTION	ASSEMBLY NUMBER
P220DA	5/32"	.281"	4.50"	Double Acting	0735-0100
P220DAR	5/32"	.281"	4.50"	Double Acting, Retractable Pistons	0736-0110
P220DB	1/4"	.375"	4.50"	Double Acting	0735-0200
P220DBR	1/4"	.375"	4.50"	Double Acting, Retractable Pistons	0736-0210
P220DE	1/2"	.625"	5.00"	Double Acting	0735-0300
P220DER	1/2"	.625"	5.00"	Double Acting, Retractable Pistons	0736-0310

### SINGLE ACTING

FIXED MOUNT - FLOATING DISC

Accommodates disc thickness: 5/32" 1/4" 1/2"

Weight 3.0 lbs. 1.36 kgs.

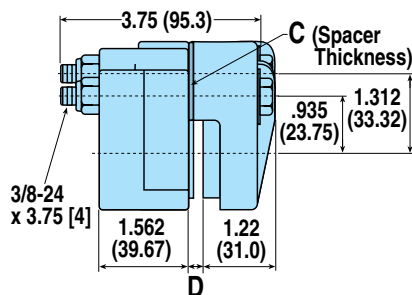

MODEL CODE	DISC THK.	C	D	OPTIONS / DESCRIPTION	ASSEMBLY NUMBER
P220SA	5/32"	—	.25"	Single Acting	0733-0000
P220SB	1/4"	.094"	.34"	Single Acting	0733-0100
P220SE	1/2"	.344"	.59"	Single Acting	0733-0200

### BRAKE MODEL LETTER CODES

<b>A</b> 5/32" Thick Disc	<b>E</b> 1/2" Thick Disc	<b>R</b> Retractable Piston(s)
<b>B</b> 1/4" Thick Disc	<b>F</b> Floating Bracket Mount	<b>S</b> Single Acting
<b>D</b> Double Acting	<b>P</b> Pneumatic Brake	

### SINGLE ACTING WITH FLOATING BRACKET

FLOATING MOUNT - FIXED DISC

Accommodates disc thickness: 5/32" 1/4" 1/2"

Weight 4.5 lbs. 2.04 kgs.

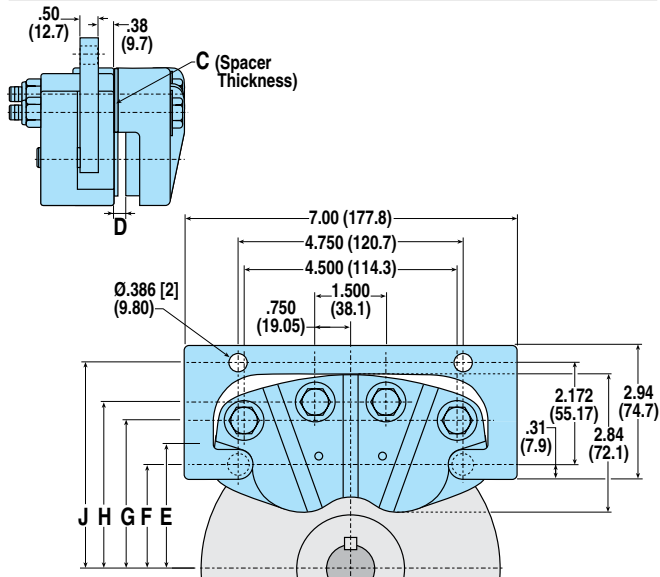

See SINGLE ACTING dimensional drawing for additional measurements

MODEL CODE	DISC THK.	C	D	OPTIONS / DESCRIPTION	ASSEMBLY NUMBER
P220SAF	5/32"	—	.25"	Single Acting, Floating Bracket	0733-0020
P220SBF	1/4"	.094"	.34"	Single Acting, Floating Bracket	0733-0120
P220SEF	1/2"	.344"	.59"	Single Acting, Floating Bracket	0733-0220

### MOUNTING DIMENSIONS

Disc Diameter	6.313"	8"	10"	12"	16"
Braking Radius	<b>E</b> 2.36"	3.18"	4.14"	5.11"	7.17"
	<b>F</b> 2.11"	3.00"	4.00"	5.00"	7.09"
	<b>G</b> 3.05"	3.94"	4.94"	5.94"	8.03"
	<b>H</b> 3.42"	4.32"	5.32"	6.32"	8.41"
	<b>J</b> 4.28"	5.17"	6.17"	7.17"	9.26"

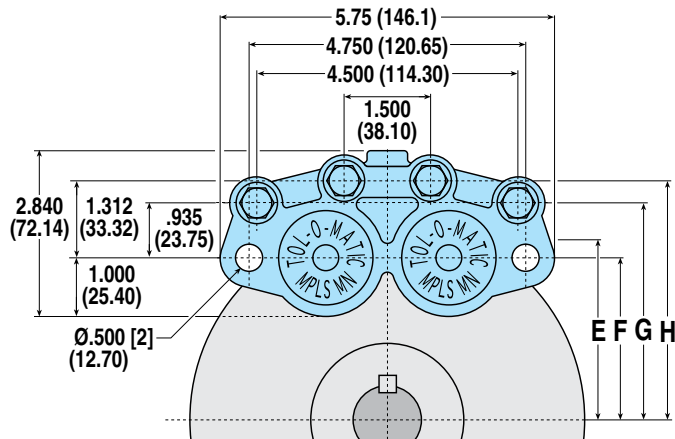

CALIPER DISC BRAKES

FEATURES

APPLICATIONS

SELECTION GRAPHS

PNEUMATIC BRAKES

P10

P20

P220

HYDRAULIC BRAKES

H10

H20

H220

H220I

H441

H960

HYDRAULIC/MECHANICAL BRAKE COMBOS

H/ME20

H/ME220

MECHANICAL BRAKES

ME10

ME20

ME220

MB3

SPRING APPLIED BRAKES

FS20

FS220

FS220I

FS595

DISCS HUBS & BUSHINGS

TENSION CONTROL COMBINATIONS

INTENSIFIER

SELECTION

WORKSHEET

## H10 SERIES - ALUMINUM

### AVAILABLE STYLES

#### Double Acting

FIXED MOUNT - FIXED DISC



PICTURED: 0701-0010

#### Single Acting

FIXED MOUNT - FLOATING DISC



PICTURED: 0705-0010

#### Single Acting with Floating Bracket

FLOATING MOUNT - FIXED DISC



PICTURED:  
0705-0011

### H10 SPECIFICATIONS

Maximum Pressure Rating:	1,000 PSI
Accommodates Tolomatic disc diameters:	6-5/16", 8", 10", 12", 16"
Maximum disc diameter:	none
Housing Material:	Extruded aluminum
Bolts:	Zinc plated grade 5
Seals:	Buna-N Standard
Wearable friction material:	0.47 in <sup>3</sup>
Wearable friction material/retractable models:	0.13 in <sup>3</sup>
Friction material:	Replaceable, high-grade
Total lining area:	1.84 in <sup>2</sup>
Total lining area/retractable materials:	1.64 in <sup>2</sup>
Piston diameter:	1.125 in.
Fluid displacement, non-retractable:	Single acting = 0.029 in <sup>3</sup> Double acting = 0.029 in <sup>3</sup>

#### OPTIONS

Seals:	EPR seals
Pistons:	Retractable piston(s)
Floating bracket:	Stamped steel construction

### PERFORMANCE DATA

#### Dynamic Torque vs Pressure

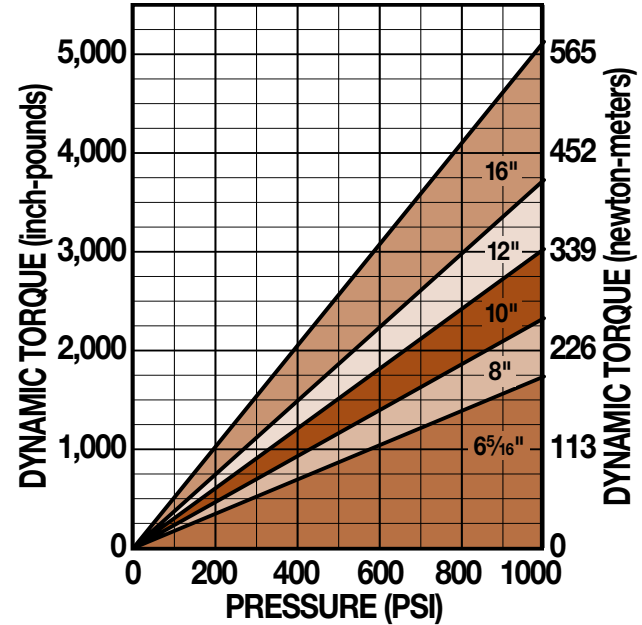

#### Static Torque vs Pressure

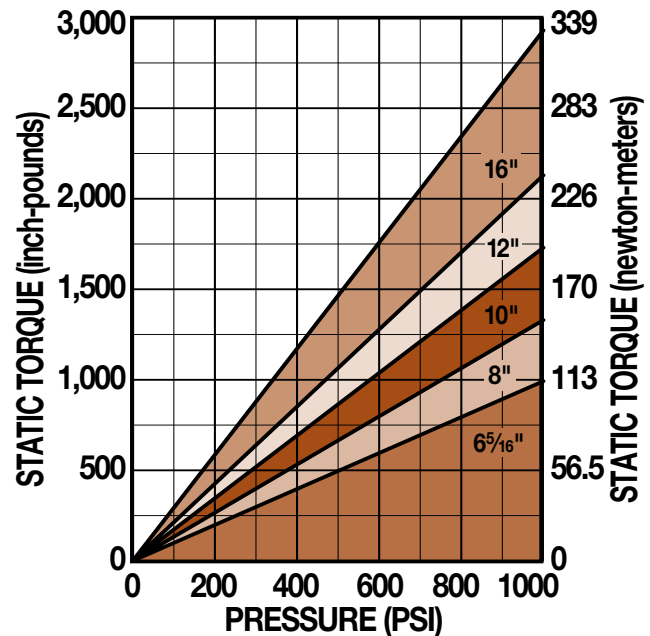

### DISC SIZING EQUATIONS

$DYNAMIC\ TORQUE\ (IN.-LBS.) = 0.70 \times BRAKING\ RADIUS\ (IN.) \times PRESSURE\ (PSI)$   
 $STATIC\ (PARKING)\ TORQUE\ (IN.-LBS.) = 0.40 \times BRAKING\ RADIUS\ (IN.) \times PRESSURE\ (PSI)$   
 $BRAKING\ RADIUS\ (IN.) = [DISC\ DIAMETER \div 2] - 0.624$

## H10 SERIES - ALUMINUM

### DOUBLE ACTING FIXED MOUNT - FIXED DISC

Accommodates disc thickness: 5/32" 1/4"

Weight 1.0 lbs. .45 kgs.

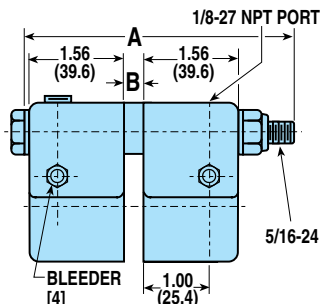

MODEL CODE	DISC THK.	A	B	OPTIONS / DESCRIPTION	ASSEMBLY NUMBER
H10DAC	5/32"	3.50"	.281"	Double Acting	0701-0010
H10DACG	5/32"	3.50"	.281"	Double Acting, EPR Seals	0701-0011
H10DARC	5/32"	3.50"	.281"	Double Acting, Retractable Pistons	0708-0010
H10DARCG	5/32"	3.50"	.281"	Double Acting, Retr Pist, EPR Seals	0708-0011
H10DBC	1/4"	3.50"	.375"	Double Acting	0702-0010
H10DBC G	1/4"	3.50"	.375"	Double Acting, EPR Seals	0702-0011
H10DBRC	1/4"	3.50"	.375"	Double Acting, Retractable Pistons	0709-0010
H10DBRC G	1/4"	3.50"	.375"	Double Acting, Retr Pist, EPR Seals	0709-0011

### SINGLE ACTING FIXED MOUNT - FLOATING DISC

Accommodates disc thickness: 5/32" 1/4"

Weight .75 lbs. .34 kgs.

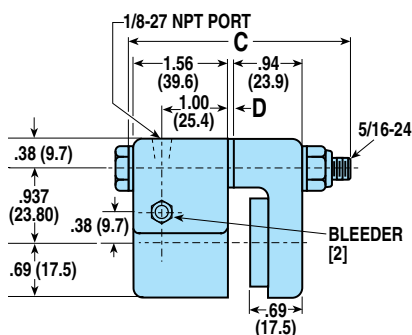

MODEL CODE	DISC THK.	C	D	OPTIONS / DESCRIPTION	ASSEMBLY NUMBER
H10SAC	5/32"	3.00"	-	Single Acting	0705-0010
H10SAC G	5/32"	3.00"	-	Single Acting, EPR Seals	0705-0008
H10SBC	1/4"	3.00"	.094"	Single Acting	0703-0010

### SINGLE ACTING WITH FLOATING BRACKET

FIXED MOUNT - FIXED DISC

Accommodates disc thickness: 5/32" 1/4"

Weight 1.5 lbs. .68 kgs.

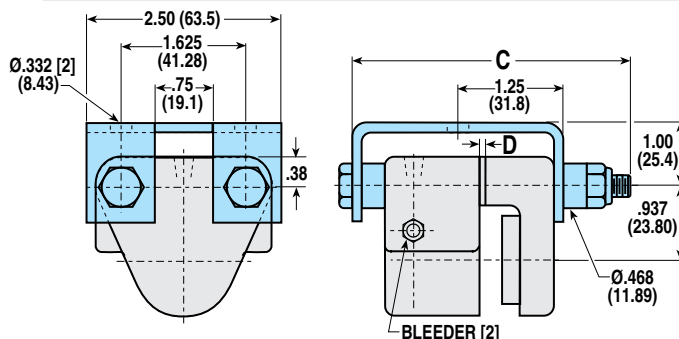

See SINGLE ACTING dimensional drawing for additional measurements

MODEL CODE	DISC THK.	C	D	OPTIONS / DESCRIPTION	ASSEMBLY NUMBER
H10SAFC	5/32"	3.75"	-	Single Acting, Floating Bracket	0705-0011
H10SAFC G	5/32"	3.75"	-	Single Acting, FtgBrkt,EPR Seals	0705-0009
H10SBFC	1/4"	3.75"	.094"	Single Acting, Floating Bracket	0703-0013

### MOUNTING DIMENSIONS

Disc Diameter	E	6.313"	8"	10"	12"	16"
F	3.469"	4.313"	5.313"	6.313"	8.313"	
Braking Radius	G	2.532"	3.376"	4.376"	5.376"	7.376"

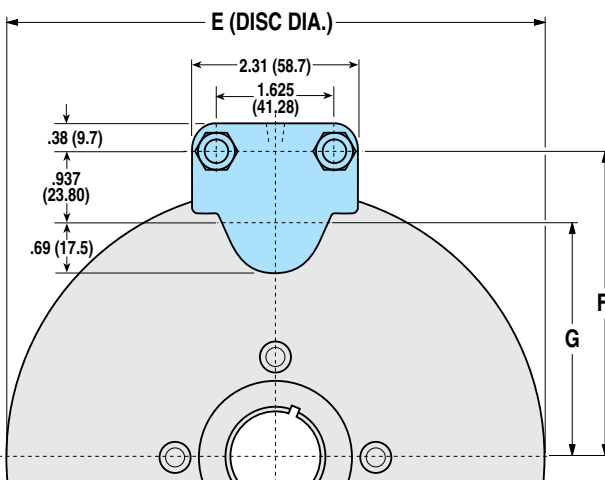

### BRAKE MODEL LETTER CODES

<b>A</b> 5/32" Thick Disc	<b>D</b> Double Acting	<b>H</b> Hydraulic Brake
<b>B</b> 1/4" Thick Disc	<b>F</b> Floating Bracket Mount	<b>R</b> Retractable Piston(s)
<b>C</b> With Bleeder Fitting	<b>G</b> EPR Seals	<b>S</b> Single Acting

CALIPER  
DISC  
BRAKES

FEATURES

APPLICATIONS

SELECTION  
GRAPHS

PNEUMATIC  
BRAKES

P10

P20

P220

HYDRAULIC  
BRAKES

H10

H20

H220

H220I

H441

H960

HYDRAULIC/  
MECHANICAL  
BRAKE  
COMBOS

H/ME20

H/ME220

MECHANICAL  
BRAKES

ME10

ME20

ME220

MB3

SPRING  
APPLIED  
BRAKES

FS20

FS220

FS220I

FS595

DISCS  
HUBS &  
BUSHINGS

TENSION  
CONTROL  
COMBINATIONS

INTENSIFIER

SELECTION

WORKSHEET

## H20 SERIES - ALUMINUM

### AVAILABLE STYLES

#### Double Acting

FIXED MOUNT - FIXED DISC



PICTURED: 0720-0010

#### Single Acting

FIXED MOUNT - FLOATING DISC



PICTURED: 0724-0010

#### Single Acting with Floating Bracket

FLOATING MOUNT - FIXED DISC



PICTURED:  
0724-0011

### H20 SPECIFICATIONS

Maximum Pressure Rating:	1,000 PSI
Accommodates Tolomatic disc diameters:	6-5/16", 8", 10", 12", 16"
Maximum disc diameter:	none
Housing Material:	Extruded aluminum
Bolts:	Zinc plated grade 8
Seals:	Buna-N Standard
Wearable friction material:	0.8 in <sup>3</sup>
Wearable friction material/retractable models:	0.5 in <sup>3</sup>
Friction material:	Replaceable, high-grade
Total lining area:	3.75 in <sup>2</sup>
Piston diameter:	1.625 in.
Fluid displacement, non-retractable:	Single acting = 0.062 in <sup>3</sup> Double acting = 0.062 in <sup>3</sup>

#### OPTIONS

Seals:	EPR seals
Pistons:	Retractable piston(s)
Floating bracket:	Stamped steel construction

### PERFORMANCE DATA

#### Dynamic Torque vs Pressure

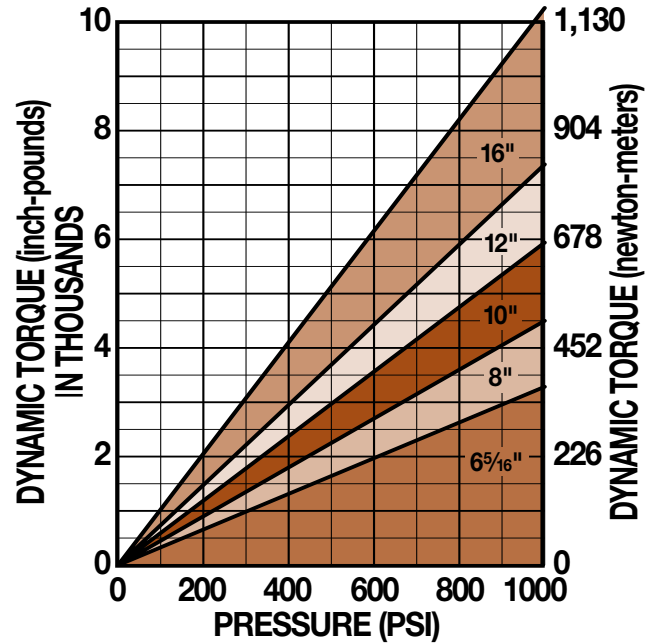

#### Static Torque vs Pressure

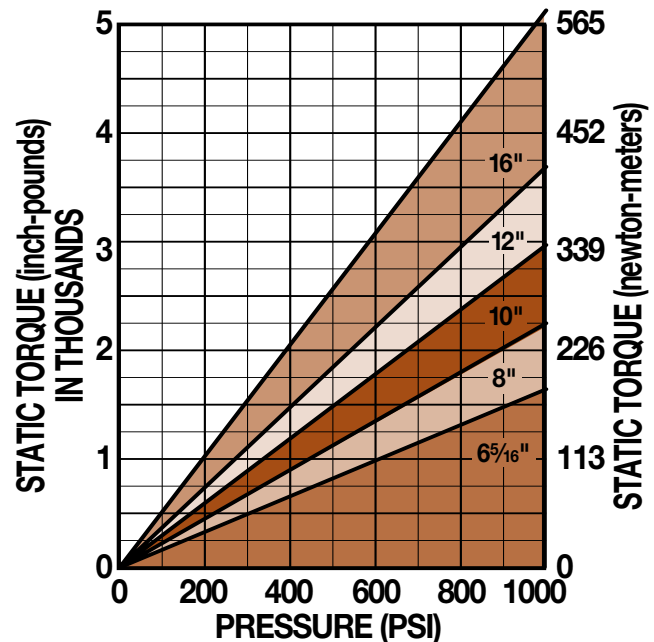

### DISC SIZING EQUATIONS

DYNAMIC TORQUE (IN.-LBS.) = 1.44 x BRAKING RADIUS (IN.) x PRESSURE (PSI)  
 STATIC (PARKING) TORQUE (IN.-LBS.) = 0.72 x BRAKING RADIUS (IN.) x PRESSURE (PSI)  
 BRAKING RADIUS (IN.) = [DISC DIAMETER ÷ 2] - 0.875

## H20 SERIES - ALUMINUM

### DOUBLE ACTING FIXED MOUNT - FIXED DISC

Accommodates disc thickness: 5/32" 1/4" 3/8" 1/2"

Weight 2.0 lbs. .91 kgs.

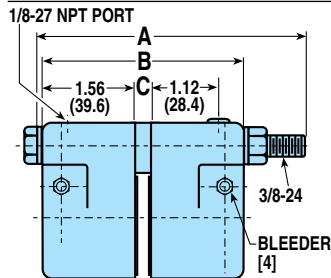

MODEL CODE	DISC THK.	A	B	C	OPTIONS / DESCRIPTION	ASSEMBLY NUMBER
H20DAC	5/32"	4.50"	3.41"	0.281"	Double Acting	0720-0010
H20DACG	5/32"	4.50"	3.41"	0.281"	Double Acting, EPR Seals	0720-0011
H20DARC	5/32"	4.50"	3.41"	0.281"	Dbl. Acting, Retractable Pistons	0728-0010
H20DARCG	5/32"	4.50"	3.41"	0.281"	Dbl. Acting, Retr. Pist, EPR Seals	0728-0011
H20DBC	1/4"	4.50"	3.50"	0.375"	Double Acting	0721-0010
H20DBCg	1/4"	4.50"	3.50"	0.375"	Double Acting, EPR Seals	0721-0011
H20DBRC	1/4"	4.50"	3.50"	0.375"	Dbl. Acting, Retractable Pistons	0729-0010
H20DBRCg	1/4"	4.50"	3.50"	0.375"	Dbl. Acting, Retr. Pist, EPR Seals	0729-0011
H20DLRC	3/8"	4.50"	3.62"	0.500"	Dbl. Acting, Retractable Pistons	0729-0008
H20DEC	1/2"	5.00"	3.75"	0.625"	Double Acting	0725-0010
H20DECg	1/2"	5.00"	3.75"	0.625"	Double Acting, EPR Seals	0725-0011
H20DERC	1/2"	5.00"	3.75"	0.625"	Dbl. Acting, Retractable Pistons	0719-0010
H20DERCG	1/2"	5.00"	3.75"	0.625"	Dbl. Acting, Retr. Pist, EPR Seals	0719-0011

### SINGLE ACTING FIXED MOUNT - FLOATING DISC

Accommodates disc thickness: 5/32" 1/4" 3/8"

Weight 1.5 lbs. .68 kgs.

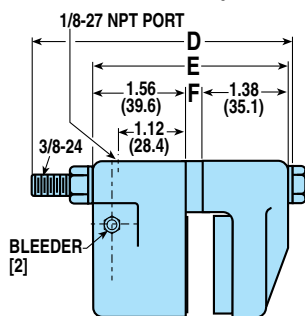

MODEL CODE	DISC THK.	D	E	F	OPTIONS / DESCRIPTION	ASSEMBLY NUMBER
H20SAC	5/32"	3.75"	2.94"	-	Single Acting	0724-0010
H20SACG	5/32"	3.75"	2.94"	-	Single Acting, EPR Seals	0724-0012
H20SBC	1/4"	3.75"	3.03"	.094"	Single Acting	0722-0010
H20SBCG	1/4"	3.75"	3.03"	.094"	Single Acting, EPR Seals	0722-0013
H20SLC	3/8"	4.00"	3.16"	.219"	Single Acting	0724-0014
H20SLCG	3/8"	4.00"	3.16"	.219"	Single Acting, EPR Seals	0724-0016

### SINGLE ACTING WITH FLOATING BRACKET

FIXED MOUNT - FIXED DISC

Accommodates disc thickness: 5/32" 1/4"

Weight 2.0 lbs. .91 kgs.

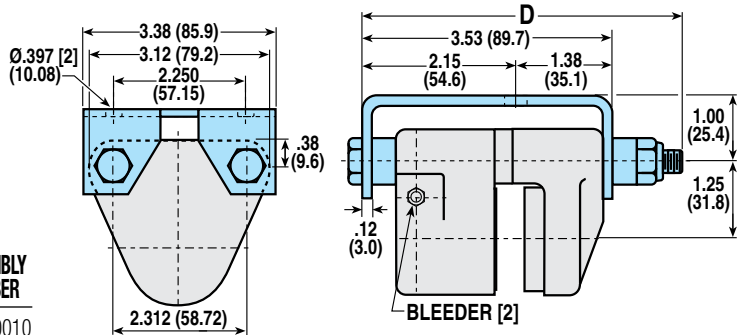

See SINGLE ACTING dimensional drawing for additional measurements

MODEL CODE	DISC THK.	D	E	F	OPTIONS / DESCRIPTION	ASSEMBLY NUMBER
H20SAFC	5/32"	4.50"	2.94"	-	Sng Act, Floating Bracket	0724-0011
H20SAFCG	5/32"	4.50"	2.94"	-	Sng Act, Fltg Brkt, EPR Seals	0724-0013
H20SBFC	1/4"	4.50"	3.03"	.094"	Sng Act, Floating Bracket	0722-0011
H20SBFCG	1/4"	4.50"	3.03"	.094"	Sng Act, Fltg Brkt, EPR Seals	0722-0014

### MOUNTING DIMENSIONS

Disc Diameter	G	6.313"	8"	10"	12"	16"
H	3.531"	4.375"	5.375"	6.375"	8.375"	
Braking Radius	J	2.281"	3.125"	4.125"	5.125"	7.125"

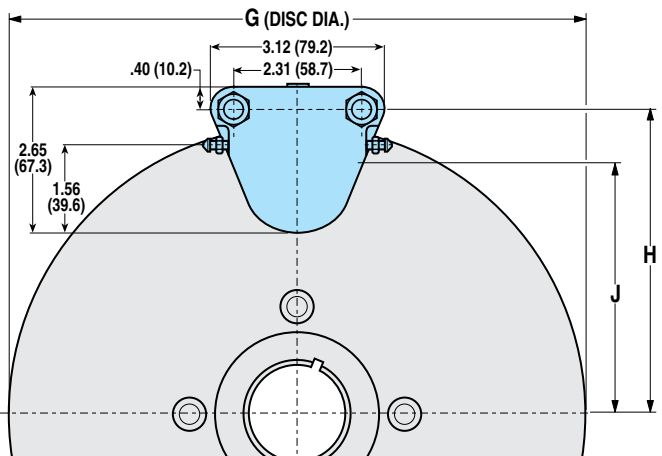

### BRAKE MODEL LETTER CODES

<b>A</b> 5/32" Thick Disc	<b>E</b> 1/2" Thick Disc	<b>L</b> 3/8" Thick Disc
<b>B</b> 1/4" Thick Disc	<b>F</b> Floating Bracket Mount	<b>R</b> Retractable Piston(s)
<b>C</b> With Bleeder Fitting	<b>G</b> EPR Seals	<b>S</b> Single Acting
<b>D</b> Double Acting	<b>H</b> Hydraulic Brake	



## H220 SERIES - ALUMINUM

### AVAILABLE STYLES

#### Double Acting

FIXED MOUNT - FIXED DISC



PICTURED: 0735-0301

#### Single Acting

FIXED MOUNT - FLOATING DISC



PICTURED: 0733-0201

#### Single Acting with Floating Bracket

FLOATING MOUNT - FIXED DISC



PICTURED:  
0733-0222

### H220 SPECIFICATIONS

Maximum Pressure Rating:	1,500 PSI
Accommodates Tolomatic disc diameters:	6-5/16", 8", 10", 12", 16"
Maximum disc diameter:	16"
Housing Material:	Die cast aluminum
Bolts:	Zinc plated grade 8
Seals:	Buna-N Standard
Wearable friction material:	1.6 in <sup>3</sup>
Wearable friction material/retractable models:	1.0 in <sup>3</sup>
Friction material:	Replaceable, high-grade
Total lining area:	7.5 in <sup>2</sup>
Piston diameter:	1.625 in.
Fluid displacement, non-retractable:	Single acting = 0.124 in <sup>3</sup> Double acting = 0.124 in <sup>3</sup>

#### OPTIONS

Seals:	EPR seals
Pistons:	Retractable piston(s)
Floating bracket:	Available

### PERFORMANCE DATA

#### Dynamic Torque vs Pressure

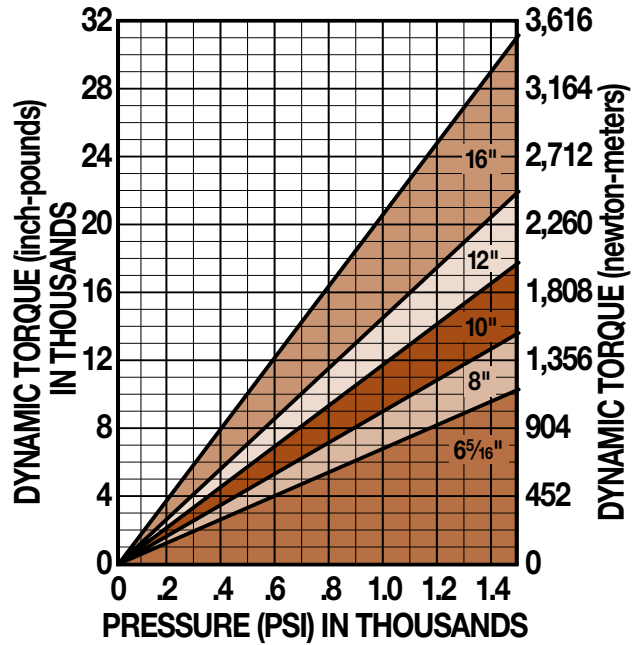

#### Static Torque vs Pressure

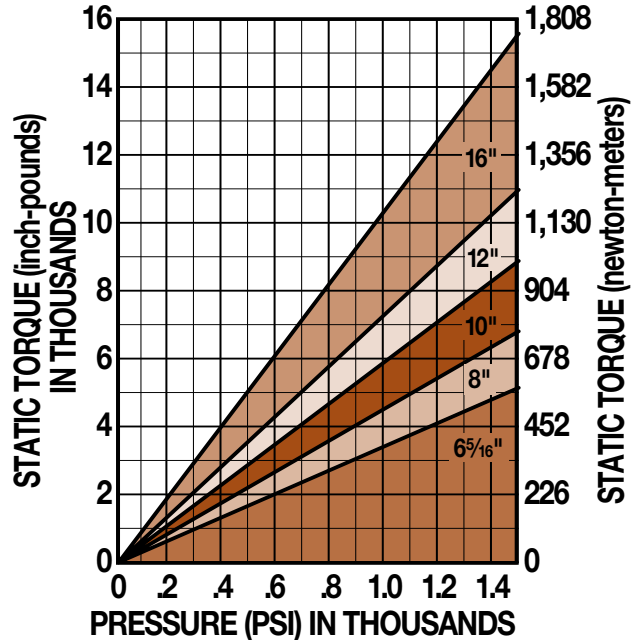

### DISC SIZING EQUATIONS

**DYNAMIC TORQUE (IN.-LBS.) = 2.88 x BRAKING RADIUS (IN.) x PRESSURE (PSI)**  
**STATIC (PARKING) TORQUE (IN.-LBS.) = 1.44 x BRAKING RADIUS (IN.) x PRESSURE (PSI)**

### BRAKE MODEL LETTER CODES

<b>A</b> 5/32" Thick Disc	<b>D</b> Double Acting	<b>H</b> Hydraulic Brake
<b>B</b> 1/4" Thick Disc	<b>E</b> 1/2" Thick Disc	<b>R</b> Retractable Piston(s)
<b>C</b> With Bleeder Fitting	<b>F</b> Floating Bracket Mount	<b>S</b> Single Acting
	<b>G</b> EPR Seals	

- FEATURES
- APPLICATIONS
- SELECTION GRAPHS
- PNEUMATIC BRAKES
- P10
- P20
- P220
- HYDRAULIC BRAKES
- H10
- H20
- H220
- H2201
- H441
- H960
- HYDRAULIC/MECHANICAL BRAKE COMBOS
- H/ME20
- H/ME220
- MECHANICAL BRAKES
- ME10
- ME20
- ME220
- MB3
- SPRING APPLIED BRAKES
- FS20
- FS220
- FS2201
- FS395
- DISCS HUBS & BUSHINGS
- TENSION CONTROL COMBINATIONS
- INTENSIFIER
- SELECTION WORKSHEET

## H220 SERIES - ALUMINUM

### DOUBLE ACTING

FIXED MOUNT - FIXED DISC

Accommodates disc thickness: 5/32" 1/4" 1/2"

Weight 4.0 lbs. 1.82 kgs.

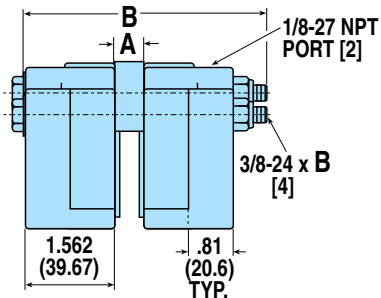

MODEL CODE	DISC THK.	A	B	OPTIONS / DESCRIPTION	ASSEMBLY NUMBER
H220DAC	5/32"	.281"	4.50"	Double Acting	0735-0101
H220DACG	5/32"	.281"	4.50"	Double Acting, EPR Seals	0735-0103
H220DARC	5/32"	.281"	4.50"	Dbl Act, Retractable Pistons	0736-0111
H220DARCG	5/32"	.281"	4.50"	Dbl Act, Retractable Pistons, EPR Seals	0736-0112
H220DBC	1/4"	.375"	4.50"	Double Acting	0735-0201
H220DBC G	1/4"	.375"	4.50"	Double Acting, EPR Seals	0735-0202
H220DBRC	1/4"	.375"	4.50"	Dbl Act, Retractable Pistons	0736-0211
H220DBRC G	1/4"	.375"	4.50"	Dbl Act, Retractable Pistons, EPR Seals	0736-0212
H220DEC	1/2"	.625"	5.00"	Double Acting	0735-0301
H220DECG	1/2"	.625"	5.00"	Double Acting, EPR Seals	0735-0302
H220DERC	1/2"	.625"	5.00"	Dbl Act, Retractable Pistons	0736-0311
H220DERCG	1/2"	.625"	5.00"	Dbl Act, Retractable Pistons, EPR Seals	0736-0312

### SINGLE ACTING

FIXED MOUNT - FLOATING DISC

Accommodates disc thickness: 5/32" 1/4" 1/2"

Weight 3.0 lbs. 1.36 kgs.

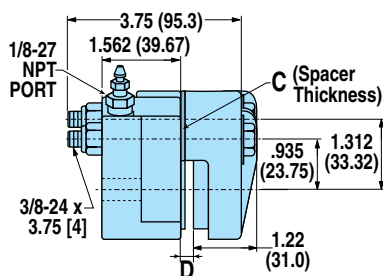

MODEL CODE	DISC THK.	C	D	OPTIONS / DESCRIPTION	ASSEMBLY NUMBER
H220SAC	5/32"	—	.25"	Single Acting	0733-0001
H220SACG	5/32"	—	.25"	Single Acting, EPR Seals	0733-0006
H220SBC	1/4"	.094"	.34"	Single Acting	0733-0101
H220SBCG	1/4"	.094"	.34"	Single Acting, EPR Seals	0733-0102
H220SEC	1/2"	.344"	.59"	Single Acting	0733-0201
H220SECG	1/2"	.344"	.59"	Single Acting, EPR Seals	0733-0202

### SINGLE ACTING WITH FLOATING BRACKET

FLOATING MOUNT - FIXED DISC

Accommodates disc thickness: 5/32" 1/4" 1/2"

Weight 4.5 lbs. 2.04 kgs.

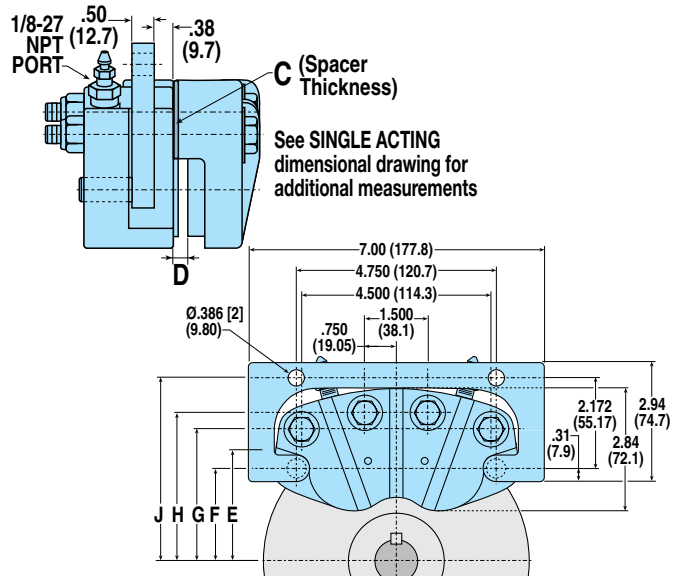

MODEL CODE	DISC THK.	C	D	OPTIONS / DESCRIPTION	ASSEMBLY NUMBER
H220SAFC	5/32"	—	.25"	Single Acting, Floating Bracket	0733-0021
H220SAFCG	5/32"	—	.25"	Sgl Act, Floating Bracket, EPR Seals	0733-0022
H220SBFC	1/4"	.094"	.34"	Sgl Act, Floating Bracket	0733-0121
H220SBFCG	1/4"	.094"	.34"	Sgl Act, Floating Bracket, EPR Seals	0733-0122
H220SEFC	1/2"	.344"	.59"	Sgl Act, Floating Bracket	0733-0221
H220SEFCG	1/2"	.344"	.59"	Sgl Act, Floating Bracket, EPR Seals	0733-0222

### MOUNTING DIMENSIONS

Disc Diameter	6.313"	8"	10"	12"	16"
Braking Radius	E 2.36"	3.18"	4.14"	5.11"	7.17"
	F 2.11"	3.00"	4.00"	5.00"	7.09"
	G 3.05"	3.94"	4.94"	5.94"	8.03"
	H 3.42"	4.32"	5.32"	6.32"	8.41"
	J 4.28"	5.17"	6.17"	7.17"	9.26"

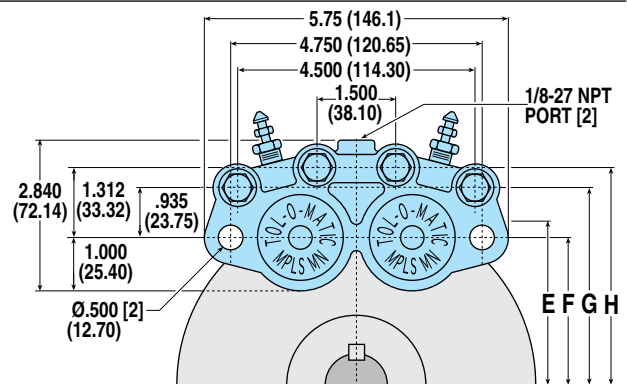

CALIPER DISC BRAKES

FEATURES

APPLICATIONS

SELECTION GRAPHS

PNEUMATIC BRAKES

P10

P20

P220

HYDRAULIC BRAKES

H10

H20

H220

H220I

H441

H960

HYDRAULIC/MECHANICAL BRAKE COMBOS

H/ME20

H/ME220

MECHANICAL BRAKES

ME10

ME20

ME220

MB3

SPRING APPLIED BRAKES

FS20

FS220

FS220I

FS595

DISCS HUBS & BUSHINGS

TENSION CONTROL COMBINATIONS

INTENSIFIER

SELECTION WORKSHEET

## H220I SERIES - CAST IRON

### AVAILABLE STYLES

#### Double Acting

FIXED MOUNT - FIXED DISC



PICTURED: 0735-0403

#### Single Acting

FIXED MOUNT - FLOATING DISC



PICTURED: 0733-0402

#### Single Acting with Floating Bracket

FLOATING MOUNT - FIXED DISC



PICTURED:  
0733-0422

### H220I SPECIFICATIONS

Maximum Pressure Rating:	1,500 PSI
Accommodates Tolomatic disc diameters:	6-5/16", 8", 10", 12", 16"
Maximum disc diameter:	16"
Housing Material:	Cast ductile iron
Bolts:	Zinc plated grade 8
Seals:	Buna-N Standard
Wearable friction material:	2.7 in <sup>3</sup>
Friction material:	Replaceable, high-grade
Total lining area:	9.6 in <sup>2</sup>
Piston diameter:	1.625 in.
Fluid displacement:	Single acting = 0.124 in <sup>3</sup> Double acting = 0.124 in <sup>3</sup>
<b>OPTIONS</b>	
Seals:	EPR seals
Floating bracket:	Available

### PERFORMANCE DATA

#### Dynamic Torque vs Pressure

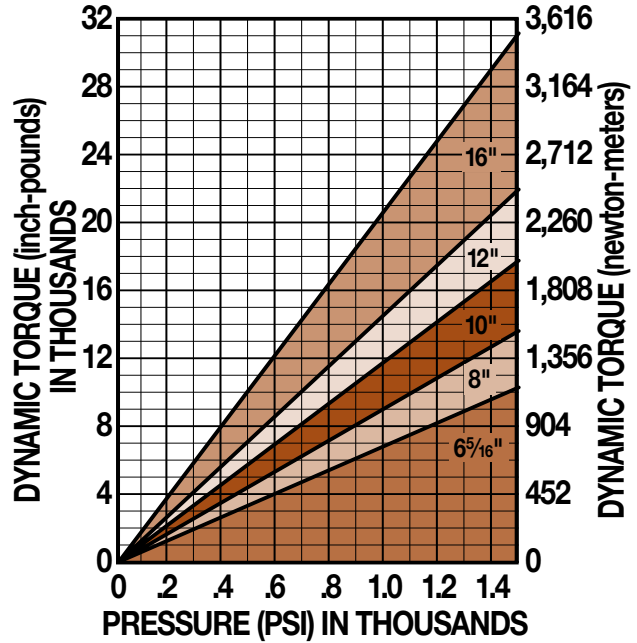

#### Static Torque vs Pressure

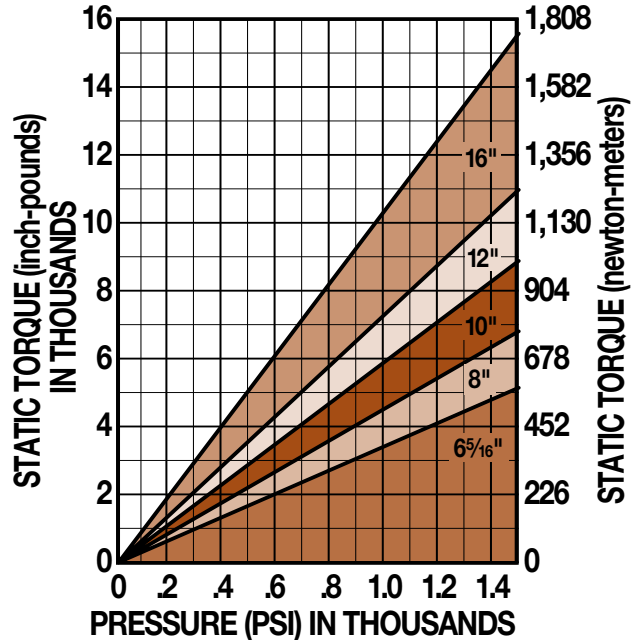

### DISC SIZING EQUATIONS

DYNAMIC TORQUE (IN.-LBS.) = 2.88 x BRAKING RADIUS (IN.) x PRESSURE (PSI)  
 STATIC (PARKING) TORQUE (IN.-LBS.) = 1.44 x BRAKING RADIUS (IN.) x PRESSURE (PSI)

### BRAKE MODEL LETTER CODES

A 5/32" Thick Disc	E 1/2" Thick Disc	L 3/8" Thick Disc
B 1/4" Thick Disc	F Floating Bracket Mount	I Iron
C With Bleeder Fitting	G EPR Seals	O 1-1/4" Thick Disc
D Double Acting	H Hydraulic Brake	S Single Acting

- FEATURES
- APPLICATIONS
- SELECTION GRAPHS
- PNEUMATIC BRAKES
- P10
- P20
- P220
- HYDRAULIC BRAKES
- H10
- H20
- H220
- H220I
- H441
- H960
- HYDRAULIC/MECHANICAL BRAKE COMBOS
- H/ME20
- H/ME220
- MECHANICAL BRAKES
- ME10
- ME20
- ME220
- MB3
- SPRING APPLIED BRAKES
- FS20
- FS220
- FS220I
- FS595
- DISCS HUBS & BUSHINGS
- TENSION CONTROL COMBINATIONS
- INTENSIFIER
- SELECTION WORKSHEET

## H220I SERIES - CAST IRON

### DOUBLE ACTING FIXED MOUNT - FIXED DISC

Accommodates disc thickness: 5/32" 1/4" 3/8" 1/2"

Weight 12.0 lbs. 5.40 kgs.

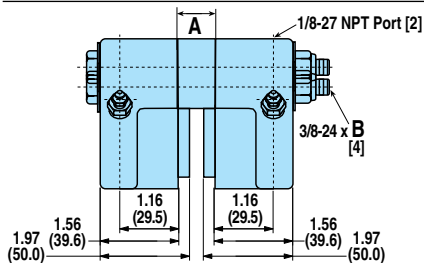

MODEL CODE	DISC THK.	A	B	OPTIONS / DESCRIPTION	ASSEMBLY NUMBER
H220DACI	5/32"	1.031"	5.00"	Double Acting, Cast Iron	0735-0403
H220DACIG	5/32"	1.031"	5.00"	Double Acting, Cast Iron, EPR Seals	0735-0407
H220DBC I	1/4"	1.125"	5.00"	Double Acting, Cast Iron	0735-0404
H220DBCIG	1/4"	1.125"	5.00"	Double Acting, Cast Iron, EPR Seals	0735-0408
H220DLCI	3/8"	1.250"	5.50"	Double Acting, Cast Iron	0735-0405
H220DLCIG	3/8"	1.250"	5.50"	Double Acting, Cast Iron, EPR Seals	0735-0409
H220DECI	1/2"	1.375"	6.00"	Double Acting, Cast Iron	0735-0406
H220DECIG	1/2"	1.375"	6.00"	Double Acting, Cast Iron, EPR Seals	0735-0410

### SINGLE ACTING FIXED MOUNT - FLOATING DISC

Accommodates disc thickness: 5/32" 1/4" 3/8" 1/2"

Weight 9.0 lbs. 4.08 kgs.

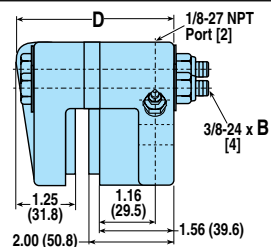

MODEL CODE	DISC THK.	B	D	OPTIONS / DESCRIPTION	ASSEMBLY NUMBER
H220SACI	5/32"	4.00"	3.45"	Single Acting, Cast Iron	0733-0402
H220SACIG	5/32"	4.00"	3.45"	Single Acting, Cast Iron, EPR Seals	0733-0406
H220SBCI	1/4"	4.00"	3.55"	Single Acting, Cast Iron	0733-0403
H220SBCIG	1/4"	4.00"	3.55"	Single Acting, Cast Iron, EPR Seals	0733-0407
H220SLCI	3/8"	4.00"	3.67"	Single Acting, Cast Iron	0733-0404
H220SLCIG	3/8"	4.00"	3.67"	Single Acting, Cast Iron, EPR Seals	0733-0408
H220SECI	1/2"	4.50"	3.79"	Single Acting, Cast Iron	0733-0405
H220SECIG	1/2"	4.50"	3.79"	Single Acting, Cast Iron, EPR Seals	0733-0409

Call **FACTORY** for dimensions for the following models:

H220SOIC	1-1/4"	Single Acting, Cast Iron	0733-0226
H220SOICG	1-1/4"	Single Acting, Cast Iron, EPR Seals	0733-0227

### SINGLE ACTING WITH FLOATING BRACKET

FIXED MOUNT - FIXED DISC

Accommodates disc thickness: 5/32" 1/4" 3/8" 1/2"

Weight 10.5 lbs. 4.76 kgs.

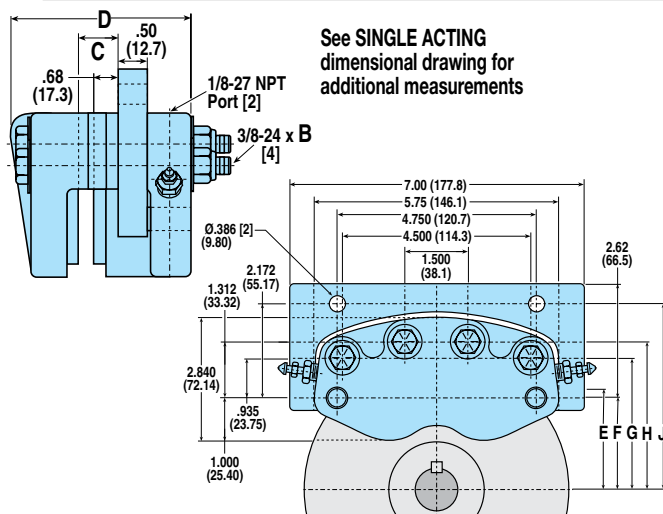

See **SINGLE ACTING** dimensional drawing for additional measurements

MODEL CODE	DISC THK.	B	C	D	OPTIONS / DESCRIPTION	ASSEMBLY NUMBER
H220SAFCI	5/32"	4.00"	.83"	3.45"	Sgl Act, Floating Bracket, Cast Iron	0733-0422
H220SAFCIG	5/32"	4.00"	.83"	3.45"	Sgl Act, Ftg Bkt, Iron, EPR Seals	0733-0426
H220SBFCI	1/4"	4.00"	.92"	3.55"	Sgl Act, Floating Bracket, Cast Iron	0733-0423
H220SBFCIG	1/4"	4.00"	.92"	3.55"	Sgl Act, Ftg Bkt, Iron, EPR Seals	0733-0427
H220SLFCI	3/8"	4.00"	1.05"	3.67"	Sgl Act, Floating Bracket, Cast Iron	0733-0424
H220SLFCIG	3/8"	4.00"	1.05"	3.67"	Sgl Act, Ftg Bkt, Iron, EPR Seals	0733-0428
H220SEFCI	1/2"	4.50"	1.17"	3.79"	Sgl Act, Floating Bracket, Cast Iron	0733-0425
H220SEFCIG	1/2"	4.50"	1.17"	3.79"	Sgl Act, Ftg Bkt, Iron, EPR Seals	0733-0429

### MOUNTING DIMENSIONS

Disc Diameter	6.313"	8"	10"	12"	16"
Braking Radius	<b>E</b> 2.36"	3.18"	4.14"	5.11"	7.17"
	<b>F</b> 2.11"	3.00"	4.00"	5.00"	7.09"
	<b>G</b> 3.05"	3.94"	4.94"	5.94"	8.03"
	<b>H</b> 3.42"	4.32"	5.32"	6.32"	8.41"
	<b>J</b> 4.28"	5.17"	6.17"	7.17"	9.26"

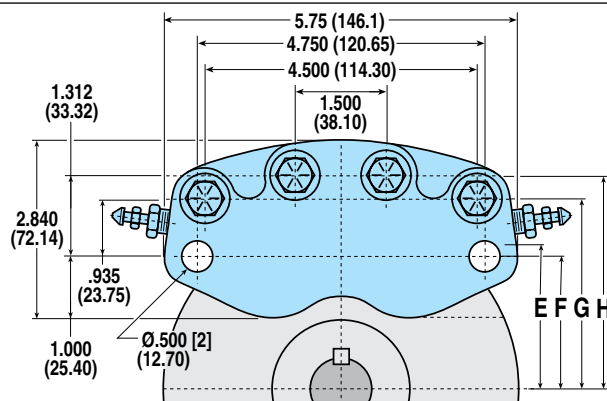

CALIPER  
DISC  
BRAKES

FEATURES

APPLICATIONS

SELECTION  
GRAPHS

PNEUMATIC  
BRAKES

P10

P20

P220

HYDRAULIC  
BRAKES

H10

H20

H220

H220I

H441

H960

HYDRAULIC/  
MECHANICAL  
BRAKE  
COMBOS

H/ME20

H/ME220

MECHANICAL  
BRAKES

ME10

ME20

ME220

MB3

SPRING  
APPLIED  
BRAKES

FS20

FS220

FS220I

FS595

DISCS  
HUBS &  
BUSHINGS

TENSION  
CONTROL  
COMBINATIONS

INTENSIFIER

SELECTION

WORKSHEET

## H441 SERIES - DUCTILE IRON

### AVAILABLE STYLES

#### Double Acting

FIXED MOUNT - FIXED DISC



PICTURED: 0774-0000

### H441 SPECIFICATIONS

Maximum Pressure Rating:	1,500 PSI
Accommodates Tolomatic disc diameters:	10", 12", 16"
Maximum disc diameter:	none
Housing Material:	Cast ductile iron
Bolts:	Zinc plated grade 5
Seals:	Buna-N Standard
Wearable friction material:	3.87 in <sup>3</sup>
Metallic:	3.38 in <sup>3</sup>
Friction material:	Replaceable, high-grade
Total lining area:	9.14 in <sup>2</sup>
Metallic:	7.36 in <sup>2</sup>
Piston diameter:	2.50 in.
Fluid displacement:	Double acting = 0.147 in <sup>3</sup>
for .03 inch clearance	

#### OPTIONS

Seals:	EPR seals
Friction material:	Sintered metallic

### BRAKE MODEL LETTER CODES

<b>D</b> Double Acting	<b>G</b> EPR Seals	<b>H</b> Hydraulic Brake
------------------------	--------------------	--------------------------

### PERFORMANCE DATA

#### Dynamic Torque vs Pressure

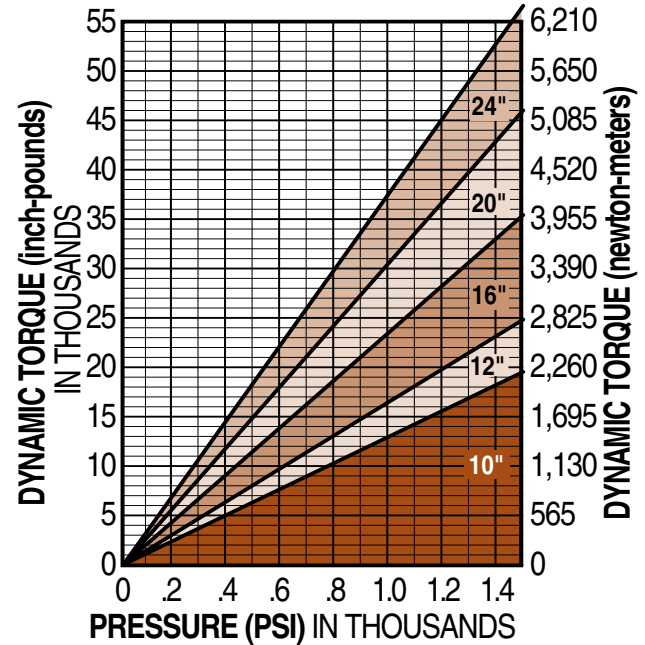

#### Static Torque vs Pressure

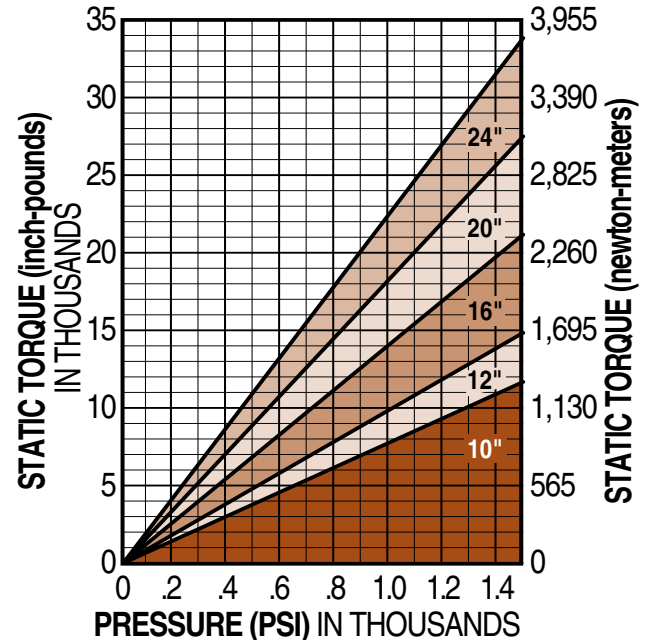

### DISC SIZING EQUATIONS

$DYNAMIC\ TORQUE\ (IN.-LBS.) = 3.53 \times BRAKING\ RADIUS\ (IN.) \times PRESSURE\ (PSI)$   
 $STATIC\ (PARKING)\ TORQUE\ (IN.-LBS.) = 2.11 \times BRAKING\ RADIUS\ (IN.) \times PRESSURE\ (PSI)$   
 $BRAKING\ RADIUS\ (IN.) = [DISC\ DIAMETER \div 2] - 1.31$



## H441 SERIES - DUCTILE IRON

### DOUBLE ACTING

FIXED MOUNT - FIXED DISC

Accommodates disc thickness: N/A

Weight 17.0 lbs. 7.71 kgs.

5/8-18 x 5.50 LONG FOR DISC THICKNESSES UP TO 1/2" [LONGER BOLTS ARE AVAILABLE]  
SPACER BY CUSTOMER TO BE 3/8" THICKER THAN DISC

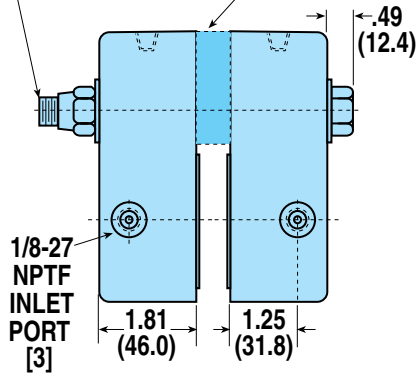

MODEL CODE	DISC THK.	OPTIONS / DESCRIPTION	ASSEMBLY NUMBER
H441D	N/A	Double Acting	0774-0000
H441DG	N/A	Double Acting, EPR Seals	0774-0001
SH441D	N/A	Double Acting, w/Sintered Metal Pads	0774-0002
SH441DG	N/A	Double Acting, EPR Seals, w/Sintered Metal Pads	0774-0003

### MOUNTING DIMENSIONS

Disc Diameter	10"	12"	16"	20"	24"
<b>A</b>	5.69"	6.69"	8.69"	10.69"	12.69"
<b>B</b>	3.69"	4.69"	6.69"	8.69"	10.69"

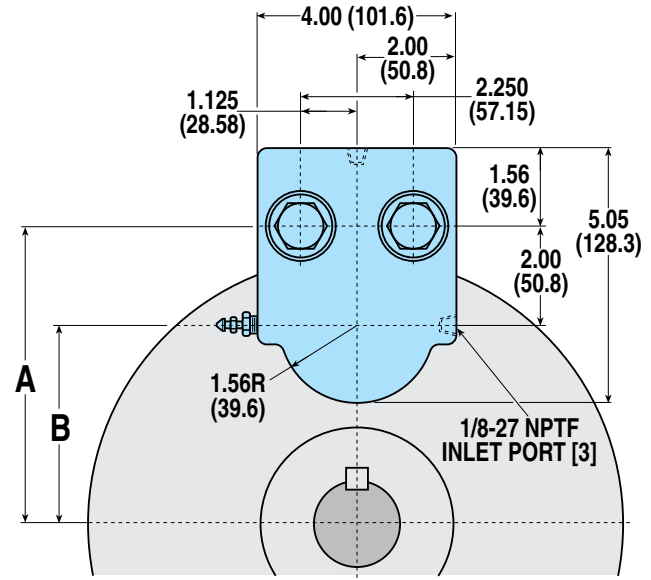

CALIPER  
DISC  
BRAKES

FEATURES

APPLICATIONS

SELECTION  
GRAPHS

PNEUMATIC  
BRAKES

P10

P20

P220

HYDRAULIC  
BRAKES

H10

H20

H220

H220I

H441

H960

HYDRAULIC/  
MECHANICAL  
BRAKE  
COMBOS

H/ME20

H/ME220

MECHANICAL  
BRAKES

ME10

ME20

ME220

MB3

SPRING  
APPLIED  
BRAKES

FS20

FS220

FS220I

FS595

DISCS  
HUBS &  
BUSHINGS

TENSION  
CONTROL  
COMBINATIONS

INTENSIFIER

SELECTION

WORKSHEET

## H960 SERIES - DUCTILE IRON

### AVAILABLE STYLES

#### Double Acting

FIXED MOUNT - FIXED DISC



PICTURED: 0778-0003

### H960 SPECIFICATIONS

Maximum Pressure Rating:	1,500 PSI (intermittent duty) 1,000 PSI (continuous duty)
Accommodates Tolomatic disc diameters:	12", 16"
Maximum disc diameter:	18"
Housing Material:	Cast ductile iron
Bolts:	Zinc plated grade 5
Seals:	Buna-N Standard
Wearable friction material:	9.9 in <sup>3</sup>
Friction material:	Replaceable, high-grade
Total lining area:	32.0 in <sup>2</sup>
Piston diameter:	3.50 in.
Fluid displacement:	Double acting = 0.576 in <sup>3</sup>

#### OPTIONS

Seals:	EPR seals
Seals:	Viton® seals

### BRAKE MODEL LETTER CODES

<b>C</b> With Bleeder Fitting	<b>H</b> Hydraulic Brake	<b>V</b> Viton® Seals
<b>D</b> Double Acting	<b>I</b> Iron	<b>X</b> Non-standard Disc Thickness
<b>E</b> 1/2" Thick Disc	<b>N</b> 1" Thick Disc	
<b>G</b> EPR Seals		

### DISC SIZING EQUATIONS

DYNAMIC TORQUE (IN.-LBS.) = 6.92 x BRAKING RADIUS (IN.) x PRESSURE (PSI)  
 STATIC (PARKING) TORQUE (IN.-LBS.) = 4.04 x BRAKING RADIUS (IN.) x PRESSURE (PSI)  
 BRAKING RADIUS (IN.) = [DISC DIAMETER ÷ 2] - 1.60

### PERFORMANCE DATA

#### Dynamic Torque vs Pressure

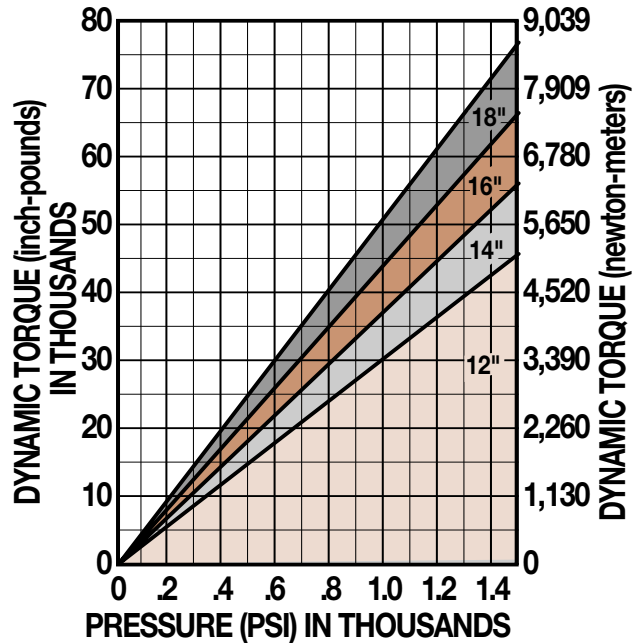

#### Static Torque vs Pressure

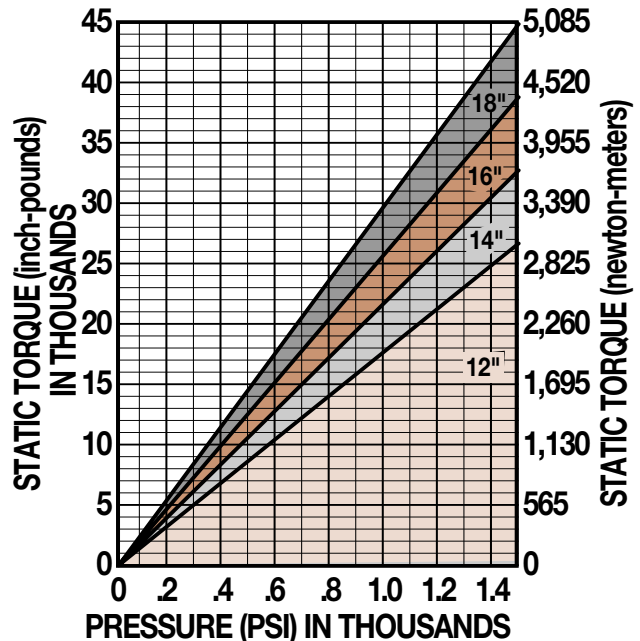

# Caliper Disc Brakes

## H960 SERIES - DUCTILE IRON

### DOUBLE ACTING

#### FIXED MOUNT - FIXED DISC

Accommodates disc thickness: 3/16" 1/2" 1" 1-1/8"

Weight 35.0 lbs. 15.88 kgs.

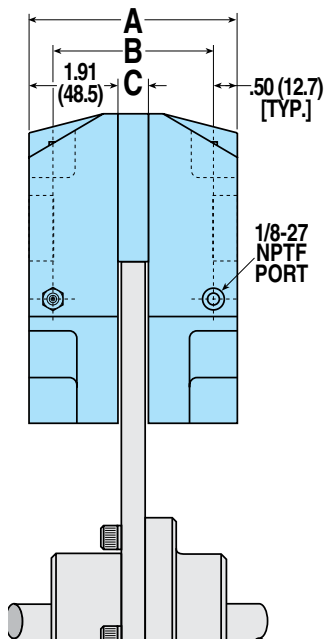

### MOUNTING DIMENSIONS

Disc Diameter	12"	14"	16"	18"
<b>D</b>	6.712"	7.712"	8.712"	9.712"
<b>E</b>	4.40"	5.40"	6.40"	7.40"

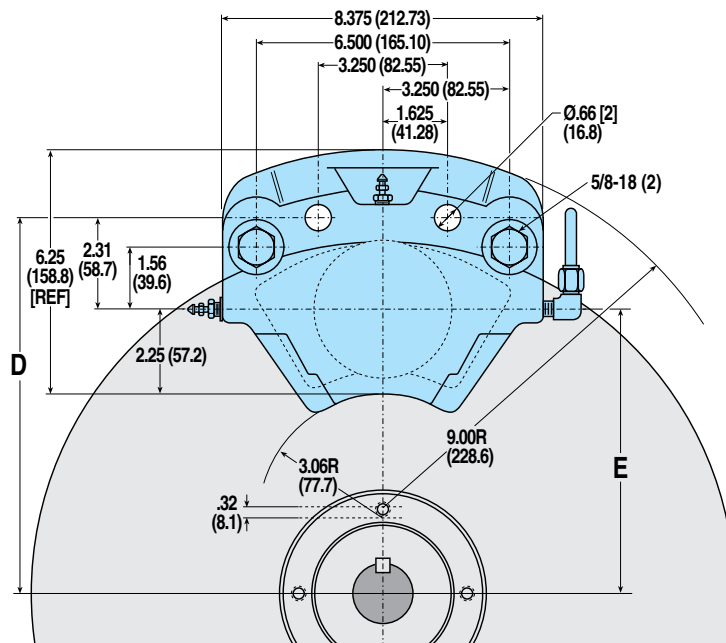

MODEL CODE	DISC THK.	A	B	C	OPTIONS / DESCRIPTION	ASSEMBLY NUMBER
H960DXCI	3/16"	4.13"	3.13"	.31"	Double Acting, Iron	0778-0012
H960DECI	1/2"	4.45"	3.45"	.63"	Double Acting, Iron	0778-0003
H960DECIG	1/2"	4.45"	3.45"	.63"	Double Acting, Iron, EPR Seals	0778-0004
H960DECIV	1/2"	4.45"	3.45"	.63"	Double Acting, Iron, Viton® Seals	0778-0005
H960DNCI	1"	4.95"	3.95"	1.13"	Double Acting, Iron	0778-0011
H960DXCI	1-1/8"	5.08"	4.08"	1.26"	Double Acting, Iron	0778-0000

Viton® is a registered trademark of the E.I. Du Pont de Nemours Co., [www.dupont.com](http://www.dupont.com)

CALIPER  
DISC  
BRAKES

FEATURES

APPLICATIONS

SELECTION  
GRAPHS

PNEUMATIC  
BRAKES

P10

P20

P220

HYDRAULIC  
BRAKES

H10

H20

H220

H220I

H441

H960

HYDRAULIC/  
MECHANICAL  
BRAKE  
COMBOS

H/ME20

H/ME220

MECHANICAL  
BRAKES

ME10

ME20

ME220

MB3

SPRING  
APPLIED  
BRAKES

FS20

FS220

FS220I

FS595

DISCS  
HUBS &  
BUSHINGS

TENSION  
CONTROL  
COMBINATIONS

INTENSIFIER

SELECTION

WORKSHEET

## H/ME20 SERIES - ALUMINUM

### AVAILABLE STYLES

#### "L" Long Lever (3.50") Single Acting

FIXED MOUNT - FLOATING DISC



PICTURED: 0755-0360

#### "L" Long Lever (3.50") Single Acting with Floating Bracket

FLOATING MOUNT - FIXED DISC



PICTURED: 0755-0260

#### "M" Machined Cam Lever (1.75") Single Acting

FIXED MOUNT - FLOATING DISC



PICTURED: 0755-0300

#### "M" Machined Cam Lever (1.75") Single Acting with Floating Bracket

FLOATING MOUNT - FIXED DISC



PICTURED: 0755-0200

#### "S" Short Lever (1.75") Single Acting

FIXED MOUNT - FLOATING DISC



PICTURED: 0755-0330

#### "S" Short Lever (1.75") Single Acting with Floating Bracket

FLOATING MOUNT - FIXED DISC



PICTURED: 0755-0230

### DISC SIZING EQUATIONS

#### HYDRAULIC:

$$\text{DYNAMIC TORQUE (IN.-LBS.)} = 1.44 \times \text{BRAKING RADIUS (IN.)} \times \text{PRESSURE (PSI)}$$

$$\text{STATIC (PARKING) TORQUE (IN.-LBS.)} = 0.72 \times \text{BRAKING RADIUS (IN.)} \times \text{PRESSURE (PSI)}$$

#### "L" LONG LEVER (3.50"):

$$\text{DYNAMIC TORQUE (IN.-LBS.)} = 5.38 \times \text{BRAKING RADIUS (IN.)} \times \text{LEVER FORCE (LBS.)}$$

$$\text{STATIC (PARKING) TORQUE (IN.-LBS.)} = 2.69 \times \text{BRAKING RADIUS (IN.)} \times \text{LEVER FORCE (LBS.)}$$

#### "M" MACHINED CAM (1.75") & "S" SHORT LEVER (1.75"):

$$\text{DYNAMIC TORQUE (IN.-LBS.)} = 2.69 \times \text{BRAKING RADIUS (IN.)} \times \text{LEVER FORCE (LBS.)}$$

$$\text{STATIC (PARKING) TORQUE (IN.-LBS.)} = 1.345 \times \text{BRAKING RADIUS (IN.)} \times \text{LEVER FORCE (LBS.)}$$

### H/ME20 SPECIFICATIONS

Maximum Hydraulic Pressure Rating:	1,000 PSI
Maximum lever force "L" Long Lever:	225 Lbs.
Maximum lever force "M" & "S" Levers:	450 Lbs.
Accommodates Tolomatic disc diameters:	6-5/16", 8", 10", 12", 16"
Maximum disc diameter:	none
Housing Material:	Cast aluminum
Bolts:	Zinc plated grade 5
Seals:	EPR Standard
Wearable friction material:	0.8 in <sup>3</sup>
Friction material:	Replaceable, high-grade
Total lining area:	3.75 in <sup>2</sup>
Piston diameter:	1.625 in.
Fluid displacement, non-retractable:	Single acting = 0.062 in <sup>3</sup>

### OPTIONS

Seals:	Buna-N seals
Floating bracket:	Stamped steel construction

### MOUNTING DIMENSIONS

Disc Diameter	6.313"	8"	10"	12"	16"
<b>D</b>	3.531"	4.375"	5.375"	6.375"	8.375"
<b>E</b>	2.281"	3.125"	4.125"	5.125"	7.125"

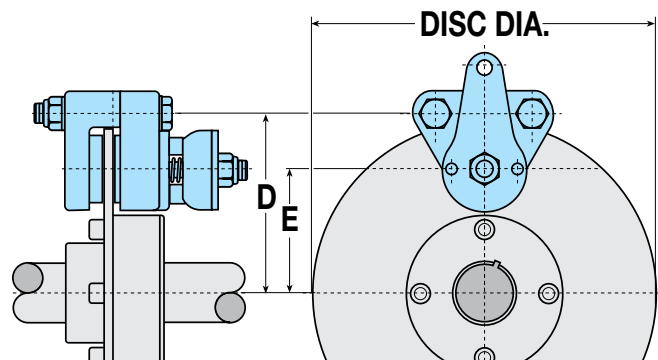

### PERFORMANCE DATA

Hydraulic - Dynamic Torque vs Pressure

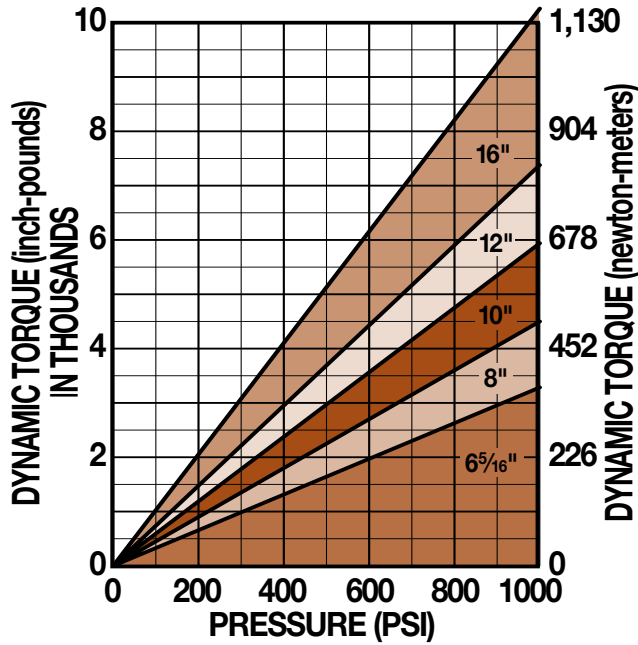

Mechanical - Dynamic Torque vs Lever Force

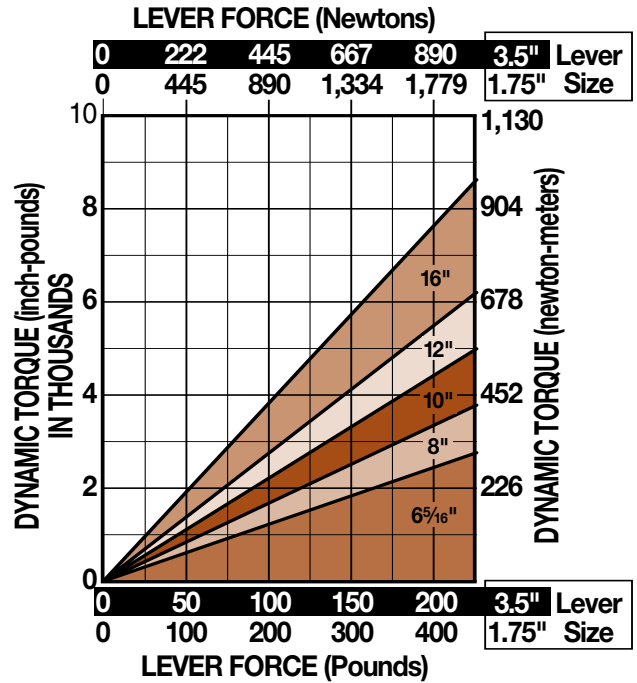

Hydraulic - Static Torque vs Pressure

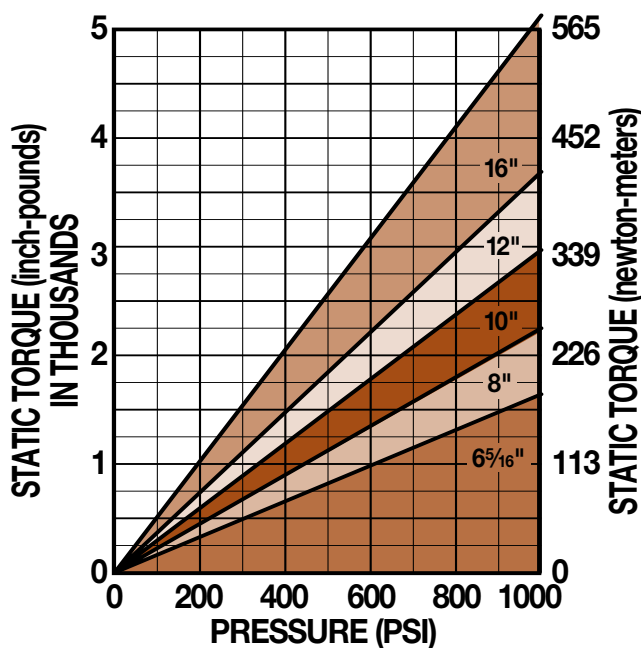

Mechanical - Static Torque vs Lever Force

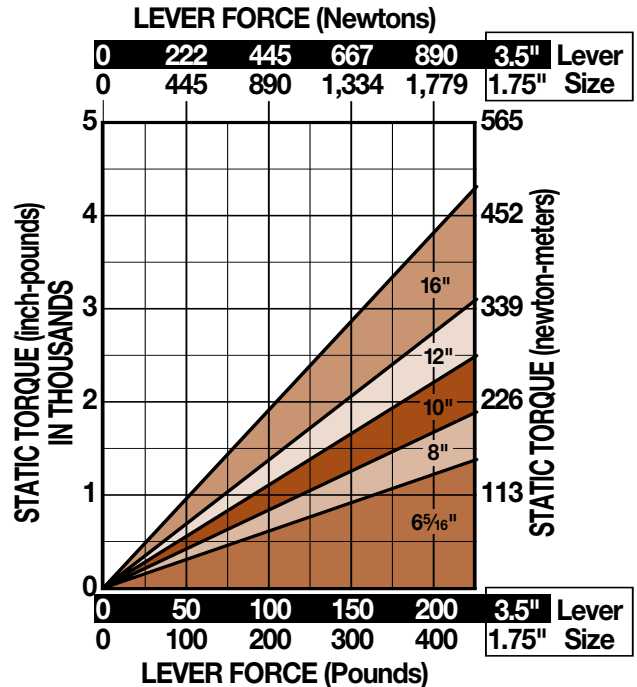



## H/ME20 SERIES - ALUMINUM

### "L" LONG LEVER - SINGLE ACTING FIXED MOUNT - FLOATING DISC

Accommodates disc thickness: 5/32" 1/4"

Weight 1.5 lbs. .68 kgs.

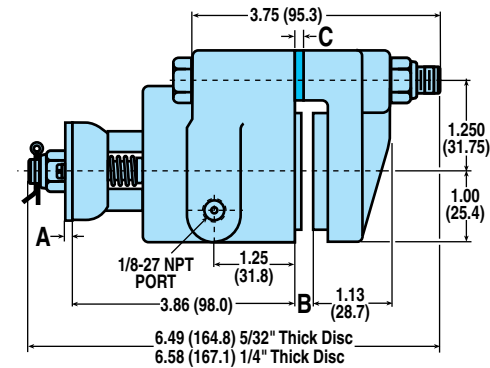
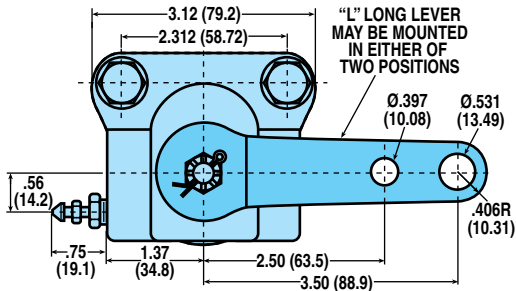

MODEL CODE	DISC THK.	A	B	C	OPTIONS / DESCRIPTION	ASSEMBLY NUMBER
H/ME20LAC	5/32"	.164"	.25"	—	Long Lever, Buna-N Seals	0755-0360
H/ME20LAGG	5/32"	.164"	.25"	—	Long Lever	0755-0660
H/ME20LBC	1/4"	.164"	.34"	.094"	Long Lever, Buna-N Seals	0755-0370
H/ME20LBCG	1/4"	.164"	.34"	.094"	Long Lever	0755-0670

### "L" LONG LEVER - SINGLE ACTING WITH FLOATING BRACKET

Accommodates disc thickness: 5/32" 1/4"

Weight 2.25 lbs. 1.02 kgs.

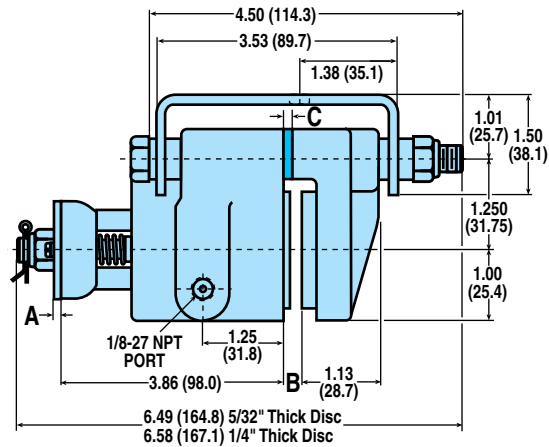
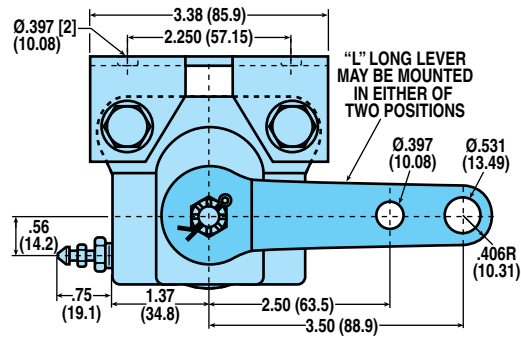

MODEL CODE	DISC THK.	A	B	C	OPTIONS / DESCRIPTION	ASSEMBLY NUMBER
H/ME20L AFC	5/32"	.164"	.25"	—	Long Lever, Fltng Brkt, Buna-N	0755-0260
H/ME20L AFCG	5/32"	.164"	.25"	—	Long Lever, Fltng Brkt	0755-0560
H/ME20L BFC	1/4"	.164"	.34"	.094"	Long Lever, Fltng Brkt, Buna-N	0755-0270
H/ME20L BFCG	1/4"	.164"	.34"	.094"	Long Lever, Fltng Brkt,	0755-0570

### CAM TRAVEL DATA

- 15° maximum travel when linings are new and with 1/32" gap each side of disc.
- Periodic tightening of lock nut will reduce travel of lever and will allow 1/4" wear on each lining.
- 90° maximum travel after 3/16" wear on each lining without intermediate tightening of lock nut.

### BRAKE MODEL LETTER CODES

<b>A</b> 5/32" Thick Disc	<b>G</b> EPR Seals	<b>ME</b> Mechanical Brake
<b>B</b> 1/4" Thick Disc	<b>H</b> Hydraulic Brake	<b>S</b> Short Lever (ME Brakes)
<b>C</b> With Bleeder Fitting	<b>L</b> Long Lever (ME Brakes)	
<b>F</b> Floating Bracket Mount	<b>M</b> Machined Cam (ME Brakes)	

## H/ME20 SERIES - ALUMINUM

### "M" MACHINED CAM - SINGLE ACTING FIXED MOUNT - FLOATING DISC

Accommodates disc thickness: 5/32" 1/4"

Weight 1.5 lbs. .68 kgs.

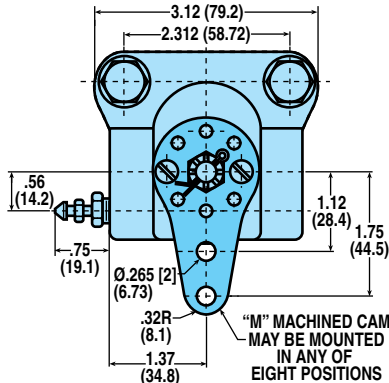

See "L" LONG LEVER SINGLE ACTING dimensional drawing for additional measurements

MODEL CODE	DISC THK.	A	B	C	OPTIONS / DESCRIPTION	ASSEMBLY NUMBER
H/ME20MAC	5/32"	.105"	.25"	—	Machined Cam, Buna-N Seals	0755-0300
H/ME20MACG	5/32"	.105"	.25"	—	Machined Cam	0755-0600
H/ME20MBC	1/4"	.105"	.34"	.094"	Machined Cam, Buna-N Seals	0755-0310
H/ME20MBCG	1/4"	.105"	.34"	.094"	Machined Cam	0755-0610

### "M" MACHINED CAM - SINGLE ACTING WITH FLOATING BRACKET

FLOATING MOUNT - FIXED DISC

Accommodates disc thickness: 5/32" 1/4"

Weight 2.25 lbs. 1.02 kgs.

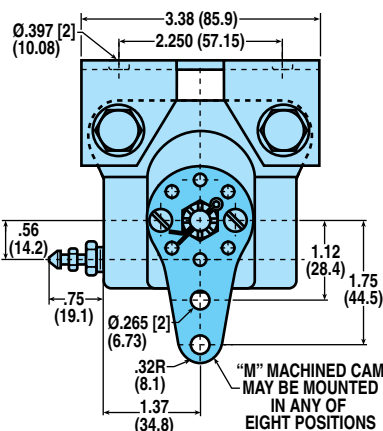

See "L" LONG LEVER SINGLE ACTING WITH FLOATING BRACKET dimensional drawing for additional measurements

MODEL CODE	DISC THK.	A	B	C	OPTIONS / DESCRIPTION	ASSEMBLY NUMBER
H/ME20MAFC	5/32"	.105"	.25"	—	Mach Cam, Fltng Brkt, Buna-N	0755-0200
H/ME20MAFCG	5/32"	.105"	.25"	—	Mach Cam, Fltng Brkt	0755-0500
H/ME20MBFC	1/4"	.105"	.34"	.094"	Mach Cam, Fltng Brkt, Buna-N	0755-0210
H/ME20MBFCG	1/4"	.105"	.34"	.094"	Mach Cam, Fltng Brkt	0755-0510

### "S" SHORT LEVER - SINGLE ACTING FIXED MOUNT - FLOATING DISC

Accommodates disc thickness: 5/32" 1/4"

Weight 1.5 lbs. .68 kgs.

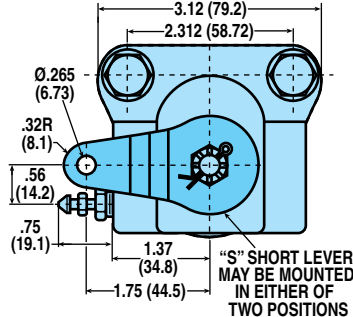

See "L" LONG LEVER SINGLE ACTING dimensional drawing for additional measurements

MODEL CODE	DISC THK.	A	B	C	OPTIONS / DESCRIPTION	ASSEMBLY NUMBER
H/ME20SAC	5/32"	.164"	.25"	—	Short Lever, Buna-N Seals	0755-0330
H/ME20SACG	5/32"	.164"	.25"	—	Short Lever	0755-0630
H/ME20SBC	1/4"	.164"	.34"	.094"	Short Lever, Buna-N Seals	0755-0340
H/ME20SBCG	1/4"	.164"	.34"	.094"	Short Lever	0755-0640

### "S" SHORT LEVER - SINGLE ACTING WITH FLOATING BRACKET

FLOATING MOUNT - FIXED DISC

Accommodates disc thickness: 5/32" 1/4"

Weight 2.25 lbs. 1.02 kgs.

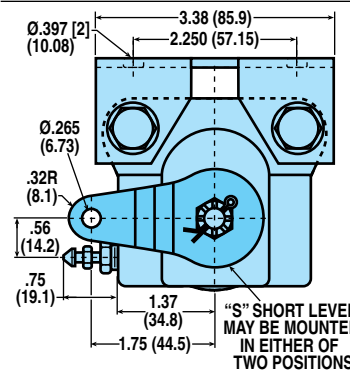

See "L" LONG LEVER SINGLE ACTING WITH FLOATING BRACKET dimensional drawing for additional measurements

MODEL CODE	DISC THK.	A	B	C	OPTIONS / DESCRIPTION	ASSEMBLY NUMBER
H/ME20SAFC	5/32"	.164"	.25"	—	Short Lever, Fltng Brkt, Buna-N	0755-0230
H/ME20SAFCG	5/32"	.164"	.25"	—	Short Lever, Fltng Brkt	0755-0530
H/ME20SBFC	1/4"	.164"	.34"	.094"	Short Lever, Fltng Brkt, Buna-N	0755-0240
H/ME20SBFCG	1/4"	.164"	.34"	.094"	Short Lever, Fltng Brkt	0755-0540

## H/ME220 SERIES - ALUMINUM

### AVAILABLE STYLES

**Single Acting with Float Pin Holes**

FIXED MOUNT - FLOATING DISC or FLOATING MOUNT - FIXED DISC



PICTURED: 0744-0630

### H/ME220 SPECIFICATIONS

Maximum Hydraulic Pressure Rating:	1,500 PSI
Maximum lever force:	580 Lbs.
Accommodates Tolomatic disc diameters:	6-5/16", 8", 10", 12", 16"
Maximum disc diameter:	16"
Housing Material:	Cast aluminum
Bolts:	Zinc plated grade 8
Seals:	EPR Standard
Wearable friction material:	1.6 in <sup>3</sup>
Friction material:	Replaceable, high-grade
Total lining area:	7.5 in <sup>2</sup>
Piston diameter:	1.625 in.
Fluid displacement:	Single acting = 0.124 in <sup>3</sup>

### OPTIONS

Seals: Buna-N seals

### CAM TRAVEL DATA

1. Gap between lining faces and disc when new = .048" total.
2. Angular movement required to actuate brake when new = 7° 30".
3. Maximum axial movement without intermediate adjustment = .387".
4. Wear allowed before adjustment .104" each side.

### DISC SIZING EQUATIONS

#### HYDRAULIC:

$$\text{DYNAMIC TORQUE (IN.-LBS.)} = 2.88 \times \text{BRAKING RADIUS (IN.)} \times \text{PRESSURE (PSI)}$$

$$\text{STATIC (PARKING) TORQUE (IN.-LBS.)} = 1.44 \times \text{BRAKING RADIUS (IN.)} \times \text{PRESSURE (PSI)}$$

#### MECHANICAL:

$$\text{DYNAMIC TORQUE (IN.-LBS.)} = 7.45 \times \text{BRAKING RADIUS (IN.)} \times \text{LEVER FORCE (LBS.)}$$

$$\text{STATIC (PARKING) TORQUE (IN.-LBS.)} = 3.725 \times \text{BRAKING RADIUS (IN.)} \times \text{LEVER FORCE (LBS.)}$$

### PERFORMANCE DATA

#### Hydraulic - Dynamic Torque vs Pressure

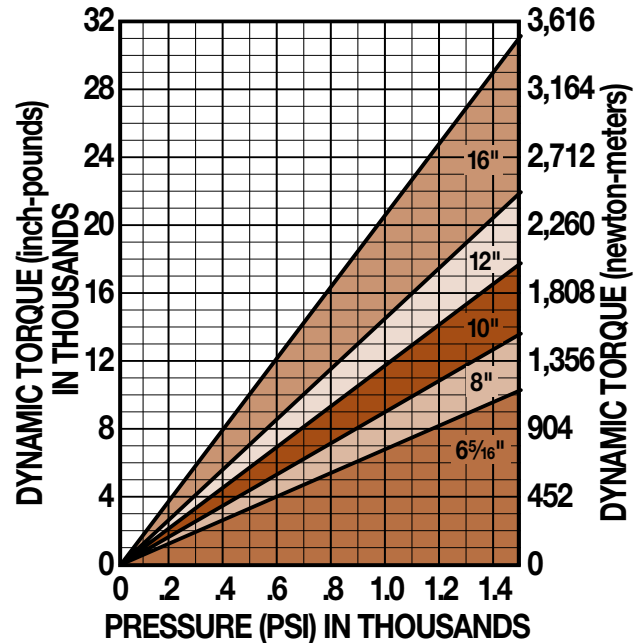

#### Hydraulic - Static Torque vs Pressure

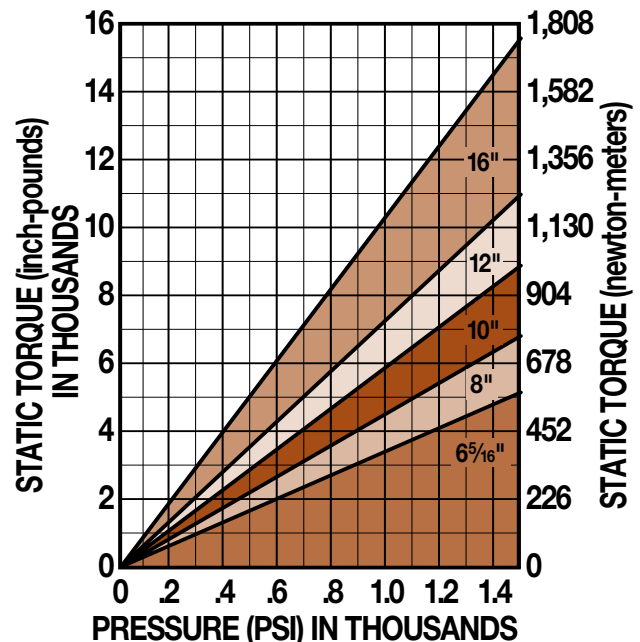

## H/ME220 SERIES - ALUMINUM

### PERFORMANCE DATA

#### Mechanical - Dynamic Torque vs Lever Force

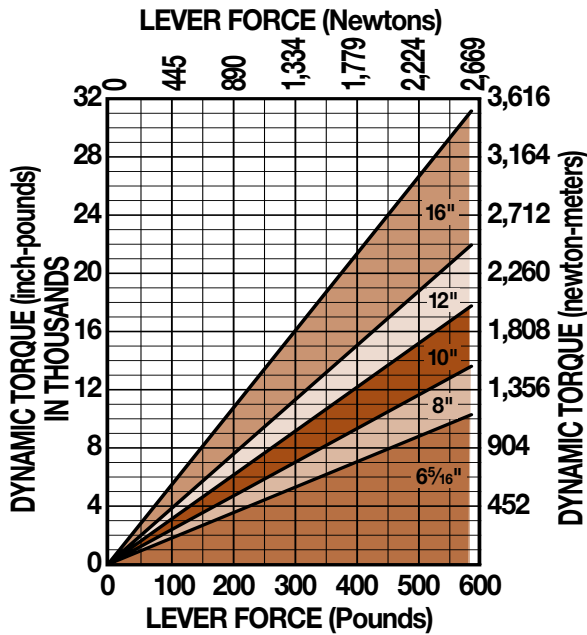

#### Mechanical - Static Torque vs Lever Force

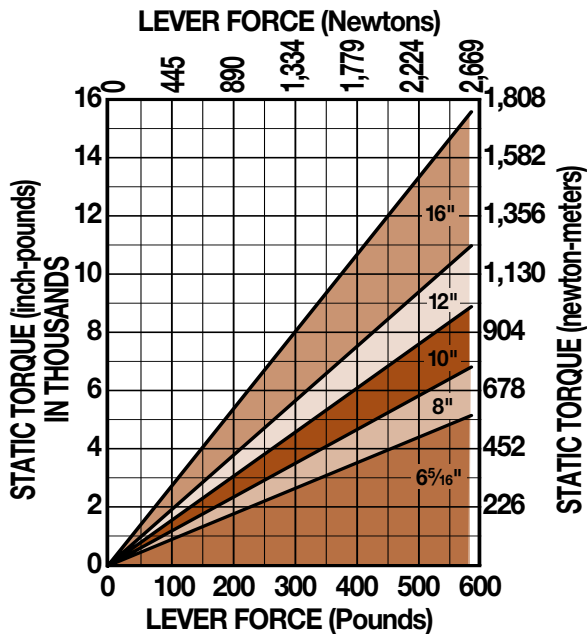

### BRAKE MODEL LETTER CODES

<b>A</b> 5/32" Thick Disc	<b>E</b> 1/2" Thick Disc	<b>L</b> 3/8" Thick Disc
<b>B</b> 1/4" Thick Disc	<b>G</b> EPR Seals	<b>ME</b> Mechanical Brake
<b>C</b> With Bleeder Fitting	<b>H</b> Hydraulic Brake	

### SINGLE ACTING WITH FLOAT PIN HOLES

FIXED MOUNT - FLOATING DISC or FLOATING MOUNT - FIXED DISC

Accommodates disc thickness: 5/32" 1/4" 3/8" 1/2"

Weight 6.00 lbs. 2.72 kgs.

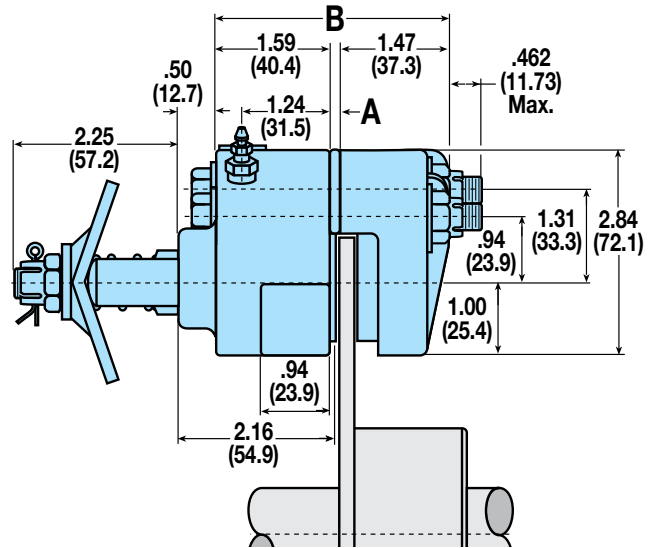

MODEL CODE	DISC THK.	A	B	OPTIONS / DESCRIPTION	ASSEMBLY NUMBER
H/ME220ACG	5/32"	.084"	3.144"	Hyd./Mech. Brake	0744-0630
H/ME220BCG	1/4"	.178"	3.238"	Hyd./Mech. Brake	0744-0640
H/ME220LCG	3/8"	.303"	3.363"	Hyd./Mech. Brake	0744-0650
H/ME220ECG	1/2"	.428"	3.488"	Hyd./Mech. Brake	0744-0660

### MOUNTING DIMENSIONS

Disc Diameter	6.313"	8"	10"	12"	16"
<b>C</b>	1.60"	2.47"	3.47"	4.47"	6.56"
Braking Radius	2.35"	3.157"	4.11"	5.08"	7.14"

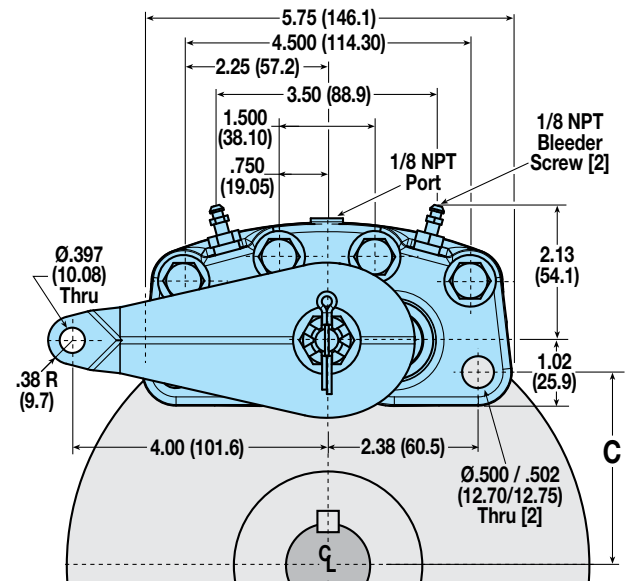

CALIPER  
DISC  
BRAKES

FEATURES

APPLICATIONS

SELECTION  
GRAPHS

PNEUMATIC  
BRAKES

P10

P20

P220

HYDRAULIC  
BRAKES

H10

H20

H220

H220I

H441

H960

HYDRAULIC/  
MECHANICAL  
BRAKE  
COMBOS

H/ME20

H/ME220

MECHANICAL  
BRAKES

ME10

ME20

ME220

MB3

SPRING  
APPLIED  
BRAKES

FS20

FS220

FS220I

FS595

DISCS  
HUBS &  
BUSHINGS

TENSION  
CONTROL  
COMBINATIONS

INTENSIFIER

SELECTION

WORKSHEET



## ME10 SERIES - ALUMINUM

### AVAILABLE STYLES

**"L" Long Lever (3.50")  
Single Acting**

FIXED MOUNT - FLOATING DISC



PICTURED: 0732-0003

**"L" Long Lever (3.50")  
Single Acting with  
Floating Bracket**

FLOATING MOUNT - FIXED DISC



PICTURED: 0732-0002

**"M" Machined Cam  
Lever (1.75")  
Single Acting**

FIXED MOUNT - FLOATING DISC



PICTURED: 0707-0000

**"M" Machined Cam  
Lever (1.75")  
Single Acting with  
Floating Bracket**

FLOATING MOUNT - FIXED DISC



PICTURED: 0707-0001

**"S" Short Lever (1.75")  
Single Acting**

FIXED MOUNT - FLOATING DISC



PICTURED: 0732-0000

**"S" Short Lever (1.75")  
Single Acting with  
Floating Bracket**

FLOATING MOUNT - FIXED DISC



PICTURED: 0732-0001

### DISC SIZING EQUATIONS

**"L" LONG LEVER (3.50"):**

$$\text{DYNAMIC TORQUE (IN.-LBS.)} = 5.38 \times \text{BRAKING RADIUS (IN.)} \times \text{LEVER FORCE (LBS.)}$$

$$\text{STATIC (PARKING) TORQUE (IN.-LBS.)} = 2.69 \times \text{BRAKING RADIUS (IN.)} \times \text{LEVER FORCE (LBS.)}$$

**"M" MACHINED CAM (1.75") & "S" SHORT LEVER (1.75"):**

$$\text{DYNAMIC TORQUE (IN.-LBS.)} = 2.69 \times \text{BRAKING RADIUS (IN.)} \times \text{LEVER FORCE (LBS.)}$$

$$\text{STATIC (PARKING) TORQUE (IN.-LBS.)} = 1.345 \times \text{BRAKING RADIUS (IN.)} \times \text{LEVER FORCE (LBS.)}$$

$$\text{BRAKING RADIUS (IN.)} = [\text{DISC DIAMETER} \div 2] - 0.624$$

### ME10 SPECIFICATIONS

Maximum lever force "L" Long Lever:	225 Lbs.
Maximum lever force "M" & "S" Levers:	450 Lbs.
Accommodates Tolomatic disc diameters:	6-5/16", 8", 10", 12", 16"
Maximum disc diameter:	none
Housing Material:	Cast aluminum
Bolts:	Zinc plated grade 5
Wearable friction material:	0.47 in <sup>3</sup>
Friction material:	Replaceable, high-grade
Total lining area:	1.84 in <sup>2</sup>
Lever / Cam:	Heat treated one-piece lever/cam or machined "V" notch cam

### OPTIONS

Floating bracket:	Stamped steel construction with zinc plated steel bushings
Additional lever positions:	Consult factory

### MOUNTING DIMENSIONS

Disc Diameter	6.313"	8"	10"	12"	16"
<b>C</b>	3.469"	4.312"	5.312"	6.312"	8.312"
<b>D</b>	2.532"	3.376"	4.376"	5.376"	7.376"

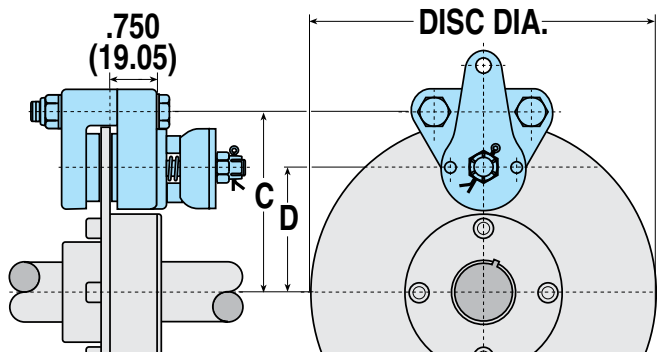

### CAM TRAVEL DATA

- 15° maximum travel when linings are new and with 1/32" gap each side of disc.
- Periodic tightening of lock nut will reduce travel of lever and will allow 1/4" wear on each lining.
- 90° maximum travel after 3/16" wear on each lining without intermediate tightening of lock nut.

## ME10 SERIES - ALUMINUM

### PERFORMANCE DATA

#### Dynamic Torque vs Lever Force

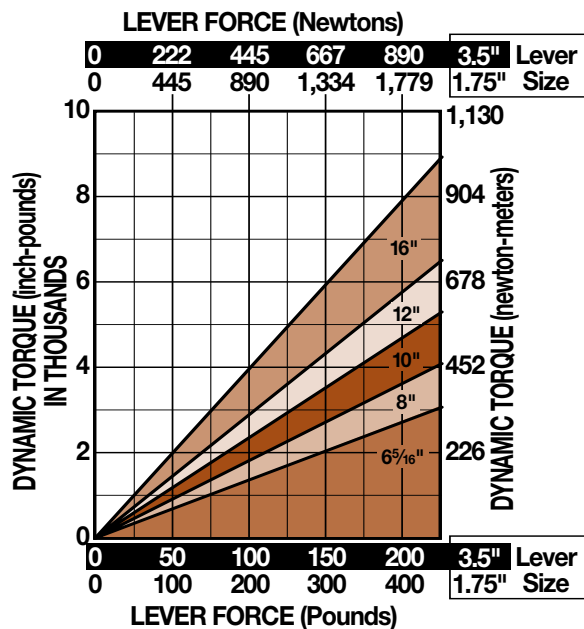

#### Static Torque vs Lever Force

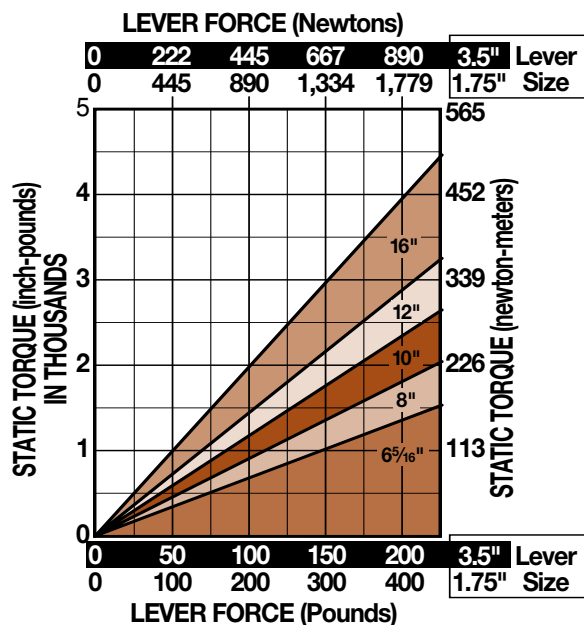

### BRAKE MODEL LETTER CODES

<b>A</b> 5/32" Thick Disc	<b>L</b> Long Lever (ME Brakes)	<b>ME</b> Mechanical Brake
<b>B</b> 1/4" Thick Disc	<b>M</b> Machined Cam (ME Brakes)	<b>S</b> Short Lever (ME Brakes)
<b>F</b> Floating Bracket Mount		

### "L" LONG LEVER - SINGLE ACTING FIXED MOUNT - FLOATING DISC

Accommodates disc thickness: 5/32"

Weight .75 lbs. .34 kgs.

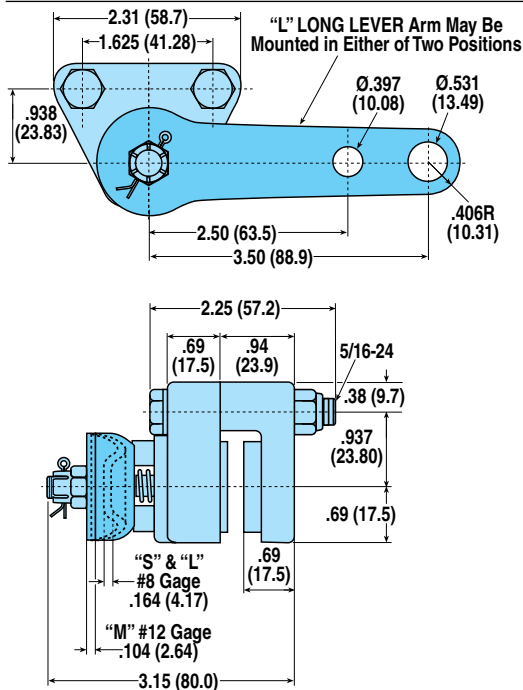

MODEL CODE	DISC THK.	OPTIONS / DESCRIPTION	ASSEMBLY NUMBER
ME10LA	5/32"	Long Lever	0732-0003

### "L" LONG LEVER - SINGLE ACTING WITH FLOATING BRACKET

FIXED MOUNT - FLOATING DISC

Accommodates disc thickness: 5/32" 1/4"

Weight 1.25 lbs. .56 kgs.

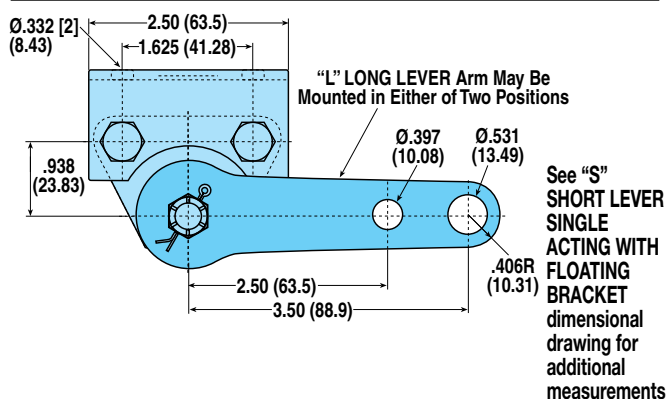

MODEL CODE	DISC THK.	A	B	OPTIONS / DESCRIPTION	ASSEMBLY NUMBER
ME10LAF	5/32"	-	3.15"	Long Lever, Floating Bracket	0732-0002
ME10LBF	1/4"	.094"	3.24"	Long Lever, Floating Bracket	0732-0004

## ME10 SERIES - ALUMINUM

### "M" MACHINED CAM - SINGLE ACTING FIXED MOUNT - FLOATING DISC

Accommodates disc thickness: 5/32"

Weight .75 lbs. .34 kgs.

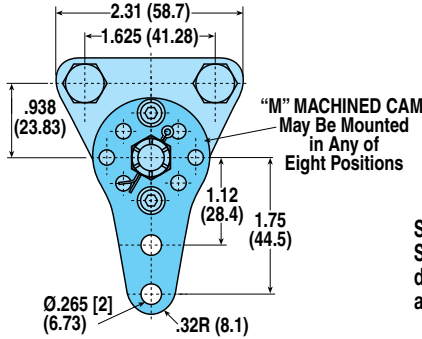

See "S" SHORT LEVER  
SINGLE ACTING  
dimensional drawing for  
additional measurements

MODEL CODE	DISC THK.	OPTIONS / DESCRIPTION	ASSEMBLY NUMBER
ME10MA	5/32"	Machined Cam	0707-0000

### "S" SHORT LEVER - SINGLE ACTING FIXED MOUNT - FLOATING DISC

Accommodates disc thickness: 5/32"

Weight .75 lbs. .34 kgs.

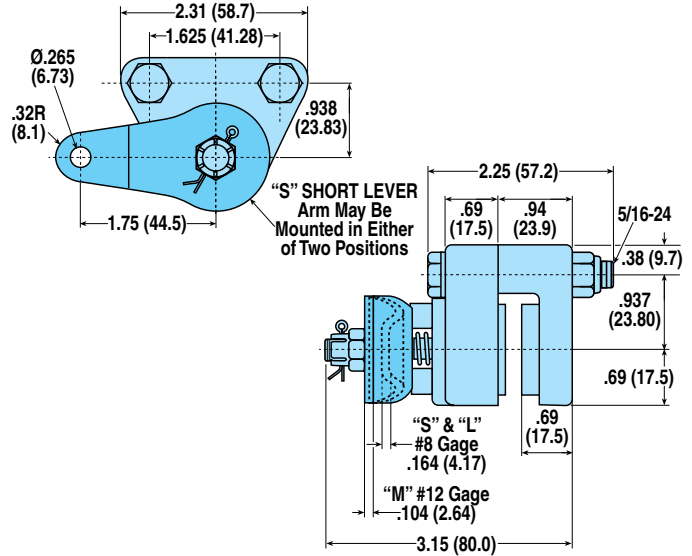

MODEL CODE	DISC THK.	OPTIONS / DESCRIPTION	ASSEMBLY NUMBER
ME10SA	5/32"	Short Lever	0732-0000

### "M" MACHINED CAM - SINGLE ACTING WITH FLOATING BRACKET

FLOATING MOUNT - FIXED DISC

Accommodates disc thickness: 5/32"

Weight 1.50 lbs. .68 kgs.

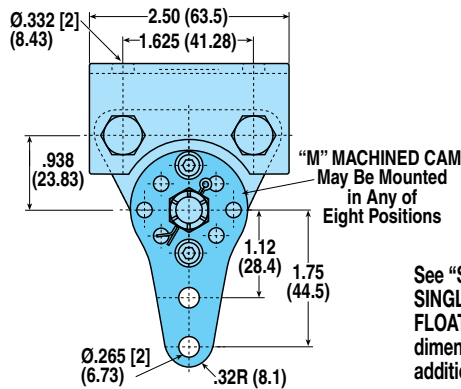

See "S" SHORT LEVER  
SINGLE ACTING WITH  
FLOATING BRACKET  
dimensional drawing for  
additional measurements

MODEL CODE	DISC THK.	A	B	OPTIONS / DESCRIPTION	ASSEMBLY NUMBER
ME10MAF	5/32"	-	3.15"	Machined Cam, Floating Bracket	0707-0001

### "S" SHORT LEVER - SINGLE ACTING WITH FLOATING BRACKET

FLOATING MOUNT - FIXED DISC

Accommodates disc thickness: 5/32" 1/4"

Weight 1.25 lbs. .56 kgs.

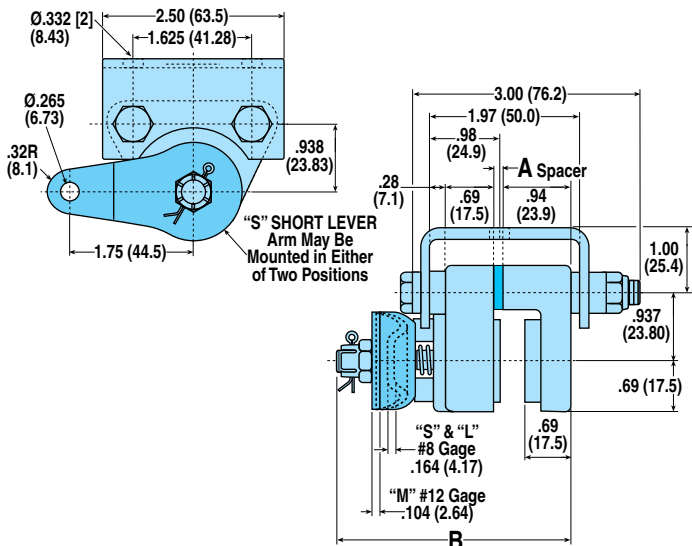

MODEL CODE	DISC THK.	A	B	OPTIONS / DESCRIPTION	ASSEMBLY NUMBER
ME10SAF	5/32"	-	3.15"	Short Lever, Floating Bracket	0732-0001
ME10SBF	1/4"	.094"	3.24"	Short Lever, Floating Bracket	0732-0005

## ME20 SERIES - ALUMINUM

### AVAILABLE STYLES

#### "L" Long Lever (3.50") Single Acting

FIXED MOUNT - FLOATING DISC



PICTURED: 0731-0003

#### "L" Long Lever (3.50") Single Acting with Floating Bracket

FLOATING MOUNT - FIXED DISC



PICTURED: 0731-0002

#### "M" Machined Cam Lever (1.75") Single Acting

FIXED MOUNT - FLOATING DISC



PICTURED: 0726-0000

#### "M" Machined Cam Lever (1.75") Single Acting with Floating Bracket

FLOATING MOUNT - FIXED DISC



PICTURED: 0726-0001

#### "S" Short Lever (1.75") Single Acting

FIXED MOUNT - FLOATING DISC



PICTURED: 0731-0000

#### "S" Short Lever (1.75") Single Acting with Floating Bracket

FLOATING MOUNT - FIXED DISC



PICTURED: 0731-0001

### DISC SIZING EQUATIONS

"L" LONG LEVER (3.50"):

$$\text{DYNAMIC TORQUE (IN.-LBS.)} = 5.38 \times \text{BRAKING RADIUS (IN.)} \times \text{LEVER FORCE (LBS.)}$$

$$\text{STATIC (PARKING) TORQUE (IN.-LBS.)} = 2.69 \times \text{BRAKING RADIUS (IN.)} \times \text{LEVER FORCE (LBS.)}$$

"M" MACHINED CAM (1.75") & "S" SHORT LEVER (1.75"):

$$\text{DYNAMIC TORQUE (IN.-LBS.)} = 2.69 \times \text{BRAKING RADIUS (IN.)} \times \text{LEVER FORCE (LBS.)}$$

$$\text{STATIC (PARKING) TORQUE (IN.-LBS.)} = 1.345 \times \text{BRAKING RADIUS (IN.)} \times \text{LEVER FORCE (LBS.)}$$

$$\text{BRAKING RADIUS (IN.)} = [\text{DISC DIAMETER} \div 2] - 0.875$$

### ME20 SPECIFICATIONS

Maximum lever force "L" Long Lever:	225 Lbs.
Maximum lever force "M" & "S" Levers:	450 Lbs.
Accommodates Tolomatic disc diameters:	6-5/16", 8", 10", 12", 16"
Maximum disc diameter:	none
Housing Material:	Cast aluminum
Bolts:	Zinc plated grade 5
Wearable friction material:	0.8 in <sup>3</sup>
Friction material:	Replaceable, high-grade
Total lining area:	3.75 in <sup>2</sup>
Lever / Cam:	Heat treated one-piece lever/cam or machined "V" notch cam

### OPTIONS

Floating bracket: Stamped steel construction with zinc plated steel bushings

Additional lever positions: Consult factory

### MOUNTING DIMENSIONS

Disc Diameter	6.313"	8"	10"	12"	16"
<b>C</b>	3.531"	4.375"	5.375"	6.375"	8.375"
<b>D</b>	2.281"	3.125"	4.125"	5.125"	7.125"

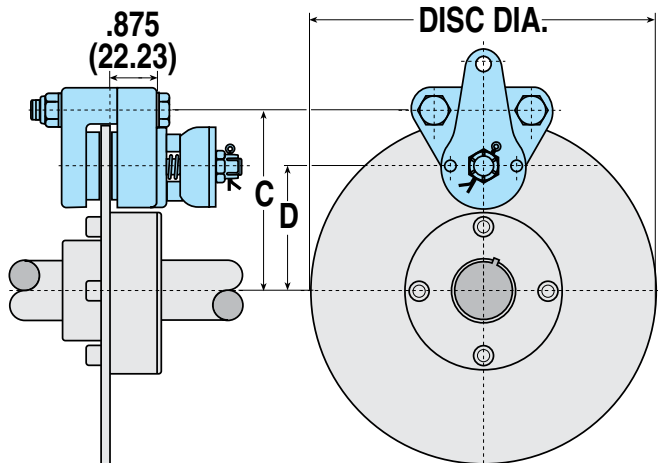

### CAM TRAVEL DATA

- 15° maximum travel when linings are new and with 1/32" gap each side of disc.
- Periodic tightening of lock nut will reduce travel of lever and will allow 1/4" wear on each lining.
- 90° maximum travel after 3/16" wear on each lining without intermediate tightening of lock nut.



## ME20 SERIES - ALUMINUM

### PERFORMANCE DATA

#### Dynamic Torque vs Lever Force

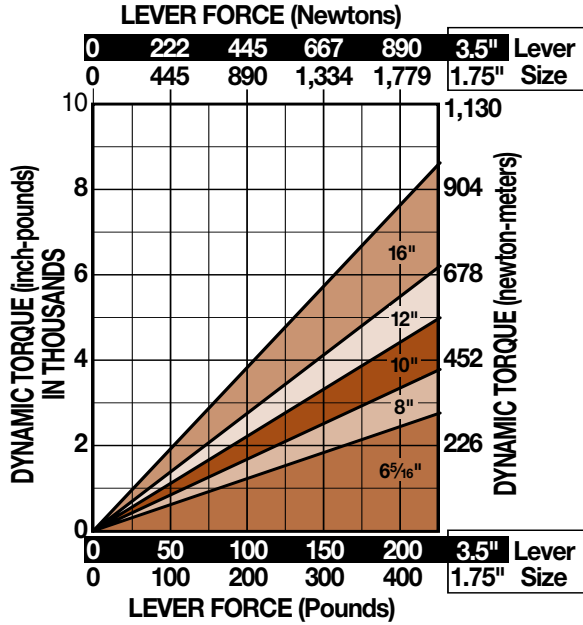

#### Static Torque vs Lever Force

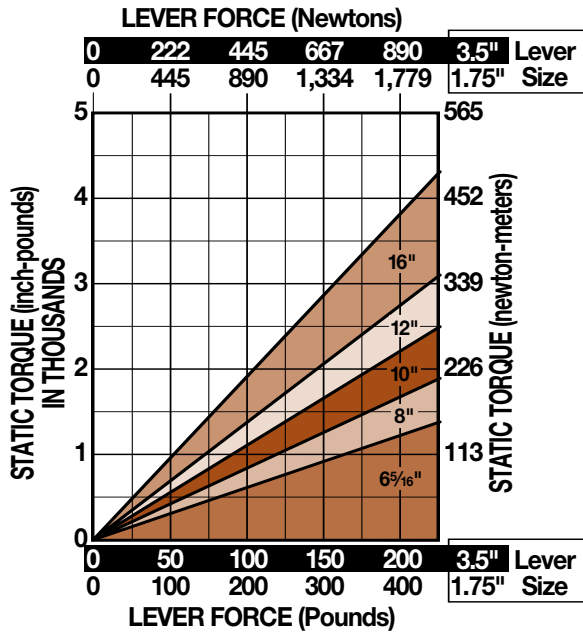

### BRAKE MODEL LETTER CODES

<b>A</b> 5/32" Thick Disc	<b>L</b> Long Lever (ME Brakes)	<b>ME</b> Mechanical Brake
<b>B</b> 1/4" Thick Disc	<b>M</b> Machined Cam (ME Brakes)	<b>S</b> Short Lever (ME Brakes)
<b>F</b> Floating Bracket Mount		

### "L" LONG LEVER - SINGLE ACTING

#### FIXED MOUNT - FLOATING DISC

Accommodates disc thickness: 5/32" 1/4"

Weight 1.50 lbs. .68 kgs.

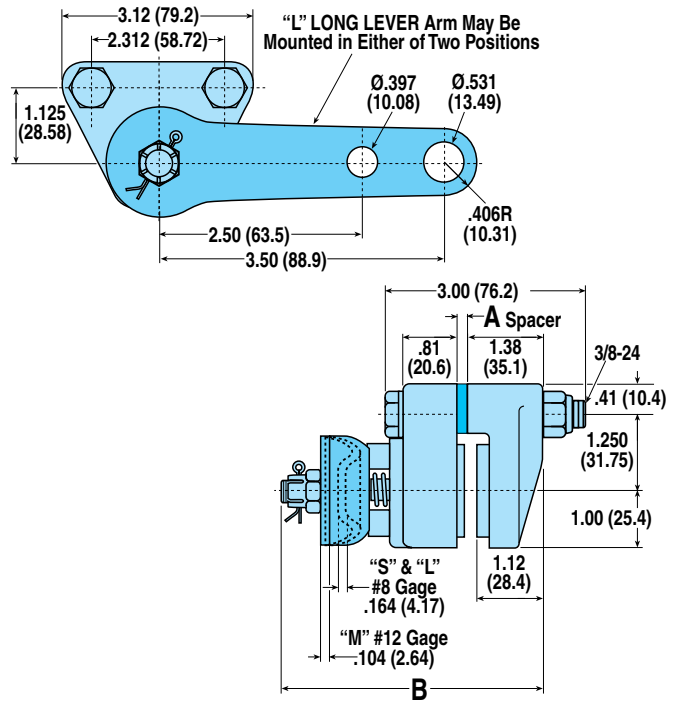

MODEL CODE	DISC THK.	A	B	OPTIONS / DESCRIPTION	ASSEMBLY NUMBER
ME20LA	5/32"	-	3.63"	Long Lever	0731-0003
ME20LB	1/4"	.094"	3.73"	Long Lever	0731-0005

### "L" LONG LEVER - SINGLE ACTING WITH FLOATING BRACKET

#### FLOATING MOUNT - FIXED DISC

Accommodates disc thickness: 5/32" 1/4"

Weight 2.25 lbs. 1.02 kgs.

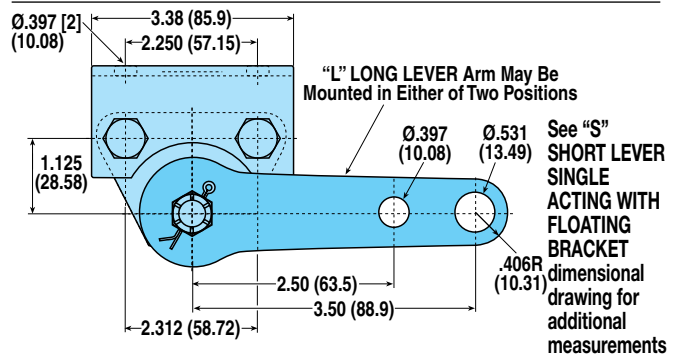

MODEL CODE	DISC THK.	A	B	OPTIONS / DESCRIPTION	ASSEMBLY NUMBER
ME20LAF	5/32"	-	3.63"	Long Lever, Floating Bracket	0731-0002
ME20LBF	1/4"	.094"	3.73"	Long Lever, Floating Bracket	0731-0006



## ME20 SERIES - ALUMINUM

### "M" MACHINED CAM - SINGLE ACTING FIXED MOUNT - FLOATING DISC

Accommodates disc thickness: 5/32" 1/4"

Weight 1.50 lbs. .68 kgs.

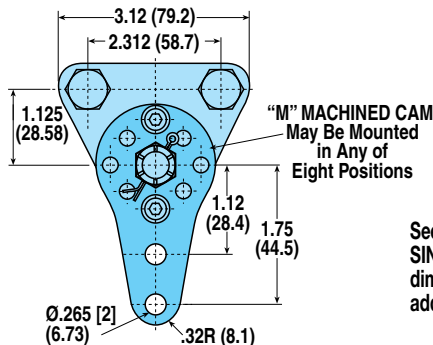

See "S" SHORT LEVER SINGLE ACTING dimensional drawing for additional measurements

MODEL CODE	DISC THK.	A	B	OPTIONS / DESCRIPTION	ASSEMBLY NUMBER
ME20MA	5/32"	-	3.63"	Machined Cam	0726-0000
ME20MB	1/4"	.094"	3.73"	Machined Cam	0726-0002

### "M" MACHINED CAM - SINGLE ACTING WITH FLOATING BRACKET FLOATING MOUNT - FIXED DISC

Accommodates disc thickness: 5/32" 1/4"

Weight 2.25 lbs. 1.02 kgs.

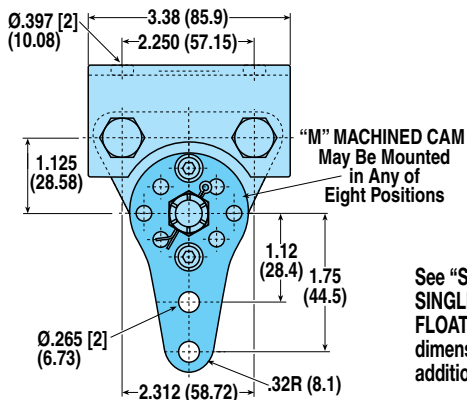

See "S" SHORT LEVER SINGLE ACTING WITH FLOATING BRACKET dimensional drawing for additional measurements

MODEL CODE	DISC THK.	A	B	OPTIONS / DESCRIPTION	ASSEMBLY NUMBER
ME20MAF	5/32"	-	3.63"	Machined Cam, Floating Bracket	0726-0001
ME20MBF	1/4"	.094"	3.73"	Machined Cam, Floating Bracket	0726-0003

### "S" SHORT LEVER - SINGLE ACTING FIXED MOUNT - FLOATING DISC

Accommodates disc thickness: 5/32" 1/4"

Weight 1.50 lbs. .68 kgs.

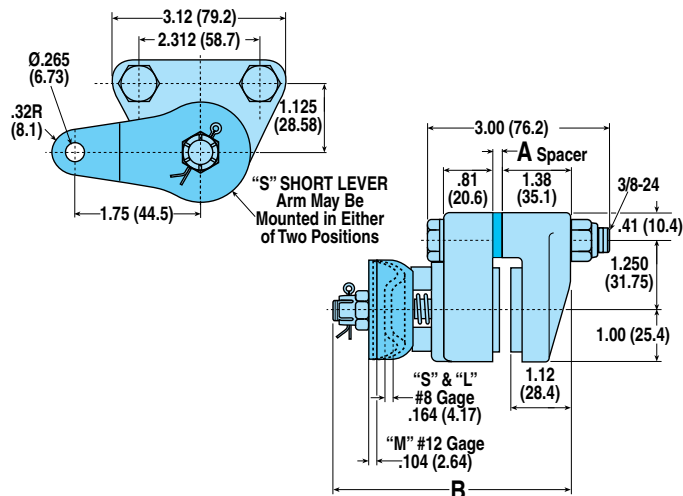

MODEL CODE	DISC THK.	A	B	OPTIONS / DESCRIPTION	ASSEMBLY NUMBER
ME20SA	5/32"	-	3.63"	Short Lever	0731-0000
ME20SB	1/4"	.094"	3.73"	Short Lever	0731-0007

### "S" SHORT LEVER - SINGLE ACTING WITH FLOATING BRACKET FLOATING MOUNT - FIXED DISC

Accommodates disc thickness: 5/32" 1/4"

Weight 2.25 lbs. 1.02 kgs.

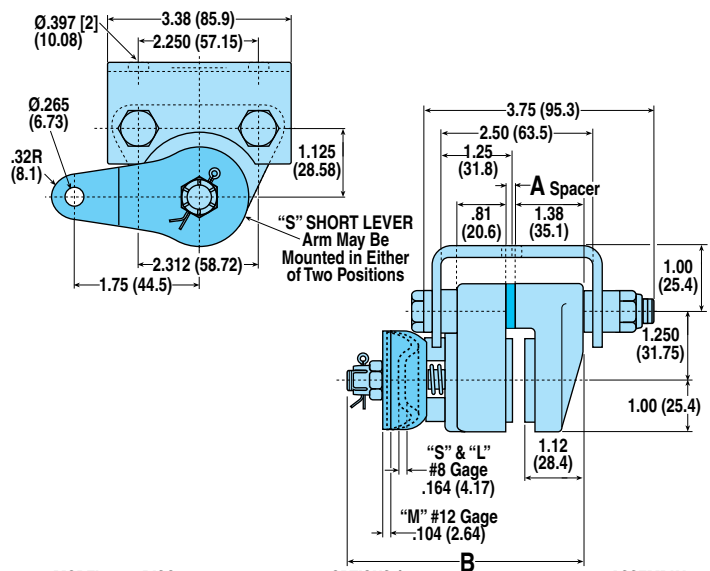

MODEL CODE	DISC THK.	A	B	OPTIONS / DESCRIPTION	ASSEMBLY NUMBER
ME20SAF	5/32"	-	3.63"	Short Lever, Floating Bracket	0731-0001
ME20SBF	1/4"	.094"	3.73"	Short Lever, Floating Bracket	0731-0004

CALIPER  
DISC  
BRAKES

FEATURES

APPLICATIONS

SELECTION  
GRAPHS

PNEUMATIC  
BRAKES

P10

P20

P220

HYDRAULIC  
BRAKES

H10

H20

H220

H220I

H441

H960

HYDRAULIC/  
MECHANICAL  
BRAKE  
COMBOS

H/ME20

H/ME220

MECHANICAL  
BRAKES

ME10

ME20

ME220

MB3

SPRING  
APPLIED  
BRAKES

FS20

FS220

FS220I

FS595

DISCS  
HUBS &  
BUSHINGS

TENSION  
CONTROL  
COMBINATIONS

INTENSIFIER

SELECTION

WORKSHEET

## ME220 SERIES - ALUMINUM OR CAST IRON

### AVAILABLE STYLES

#### Aluminum Single Acting

FIXED MOUNT - FLOATING DISC



PICTURED: 0745-0000

#### Aluminum Single Acting with Floating Bracket

FLOATING MOUNT - FIXED DISC



PICTURED: 0745-0001

#### Cast Iron Single Acting

FIXED MOUNT - FLOATING DISC



PICTURED: 0745-0002

#### Cast Iron Single Acting with Floating Bracket

FLOATING MOUNT - FIXED DISC



PICTURED: 0745-0003

### ME220 SPECIFICATIONS

Maximum lever force Aluminum Housing:	580 Lbs.
Maximum lever force Cast Iron Housing:	660 Lbs.
Accommodates Tolomatic disc diameters:	6-5/16", 8", 10", 12", 16"
Maximum disc diameter:	16"
Housing Material:	Cast aluminum or Cast ductile iron
Bolts:	Zinc plated grade 8
Wearable friction material:	1.6 in <sup>3</sup>
Friction material:	Replaceable, high-grade
Total lining area:	7.5 in <sup>2</sup>
Lever / Cam:	Heat treated one-piece lever/cam or machine "V" notch cam
Lining Wear Adjustment:	One step procedure

#### OPTIONS

Floating bracket: Available

### CAM TRAVEL DATA

1. Gap between lining faces and disc when new = .048" total.
2. Angular movement required to actuate brake when new = 7° 30".
3. Maximum axial movement without intermediate adjustment = .387".
4. Wear allowed before adjustment .104" each side.

### DISC SIZING EQUATIONS

DYNAMIC TORQUE (IN.-LBS.) = 7.45 x BRAKING RADIUS (IN.) x LEVER FORCE (LBS.)  
 STATIC (PARKING) TORQUE (IN.-LBS.) = 3.725 x BRAKING RADIUS (IN.) x LEVER FORCE (LBS.)

### PERFORMANCE DATA

#### Dynamic Torque vs Lever Force

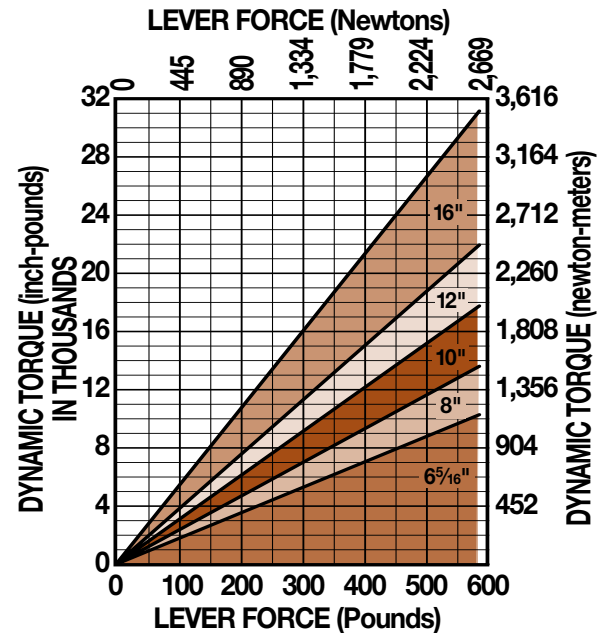

#### Static Torque vs Lever Force

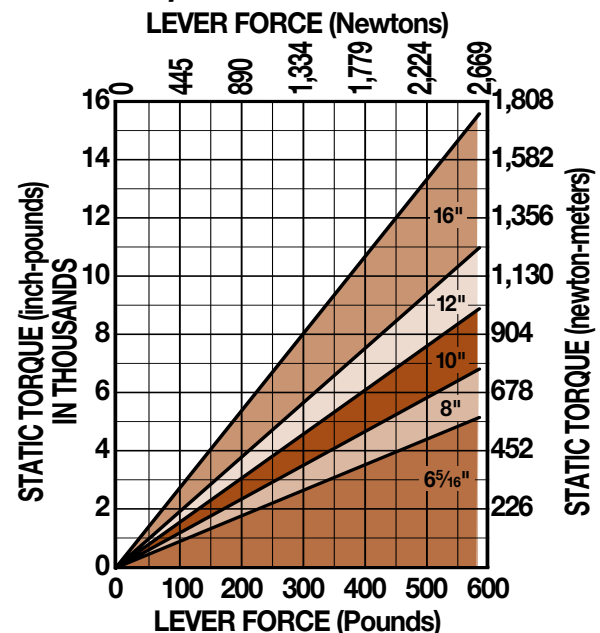

### BRAKE MODEL LETTER CODES

A 5/32" Thick Disc	L 3/8" Thick Disc
B 1/4" Thick Disc	M Machined Cam (ME Brakes)
E 1/2" Thick Disc	ME Mechanical Brake
F Floating Bracket Mount	Q 1-1/2" Thick Disc
I Iron	

## ME220 SERIES - ALUMINUM OR CAST IRON

### SINGLE ACTING FIXED MOUNT - FLOATING DISC

Accommodates disc thickness: 5/32" 1/4" 3/8" 1/2"

Aluminum Weight 6.0 lbs. 2.72 kgs.

Cast Iron Weight 10.9 lbs. 4.94 kgs.

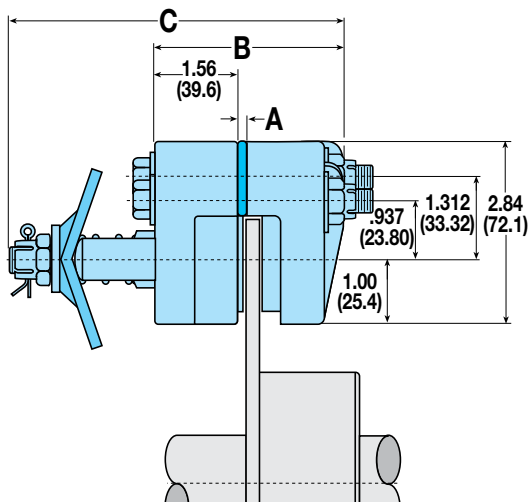

MODEL CODE	DISC THK.	A	B	C	OPTIONS / DESCRIPTION	ASSEMBLY NUMBER
ME220A	5/32"	-	3.03"	5.12"	Mechanical Brake	0745-0000
ME220MAI	5/32"	.500"	3.45"	5.64"	Machined Cam, Cast Iron	0745-0002
ME220B	1/4"	.094"	3.13"	5.22"	Mechanical Brake	0745-0010
ME220MBI	1/4"	.594"	3.55"	5.73"	Machined Cam, Cast Iron	0745-0012
ME220L	3/8"	.218"	3.25"	5.34"	Mechanical Brake	0745-0015
ME220LE	1/2"	.344"	3.38"	5.47"	Mechanical Brake	0745-0020

### MOUNTING DIMENSIONS

Disc Diameter	6.313"	8"	10"	12"	16"
<b>D</b>	2.13"	3.00"	4.00"	5.00"	7.09"
Braking Radius	2.38"	3.15"	4.11"	5.08"	7.21"

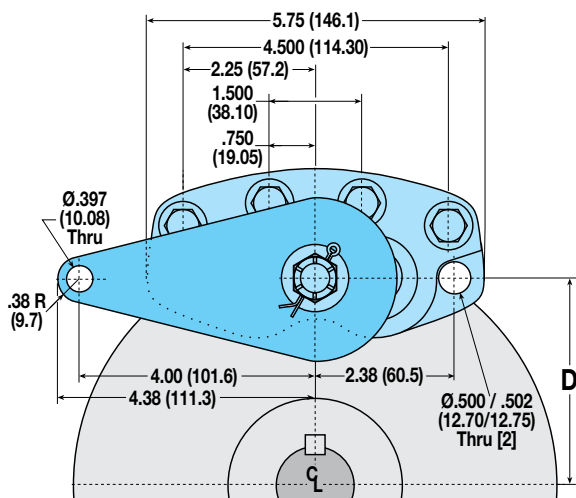

### SINGLE ACTING WITH FLOATING BRACKET

#### FIXED MOUNT - FLOATING DISC

Accommodates disc thickness: 5/32" 1/4" 3/8" 1/2" 1-1/2"

Aluminum Weight 7.5 lbs. 3.40 kgs.

Cast Iron Weight 12.4 lbs. 5.62 kgs.

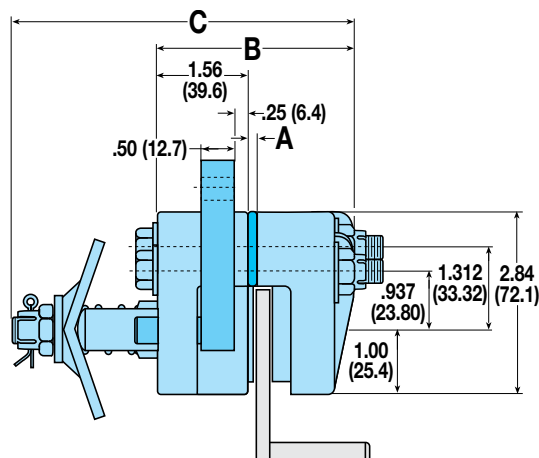

MODEL CODE	DISC THK.	A	B	C	OPTIONS / DESCRIPTION	ASSEMBLY NUMBER
ME220AF	5/32"	-	3.03"	5.12"	Floating Bracket	0745-0001
ME220MAFI	5/32"	.500"	3.45"	5.64"	Fltg Brkt, Mach Cam, Cast Iron	0745-0003
ME220BF	1/4"	.094"	3.13"	5.22"	Floating Bracket	0745-0011
ME220MBFI	1/4"	.594"	3.55"	5.73"	Fltg Brkt, Mach Cam, Cast Iron	0745-0013
ME220LF	3/8"	.218"	3.25"	5.34"	Floating Bracket	0745-0008
ME220MLFI	3/8"	.718"	3.67"	5.86"	Fltg Brkt, Mach Cam, Cast Iron	0745-0017
ME220EF	1/2"	.344"	3.38"	5.47"	Floating Bracket	0745-0021
ME220MEFI	1/2"	.844"	3.80"	5.98"	Fltg Brkt, Mach Cam, Cast Iron	0745-0024
ME220MQFI	1-1/2"	1.844"	4.80"	6.98"	Fltg Brkt, Mach Cam, Cast Iron	0745-0026

### MOUNTING DIMENSIONS

Disc Diameter	6.313"	8"	10"	12"	16"
<b>D</b>	2.13"	3.00"	4.00"	5.00"	7.09"
Braking Radius	2.38"	3.15"	4.11"	5.08"	7.21"

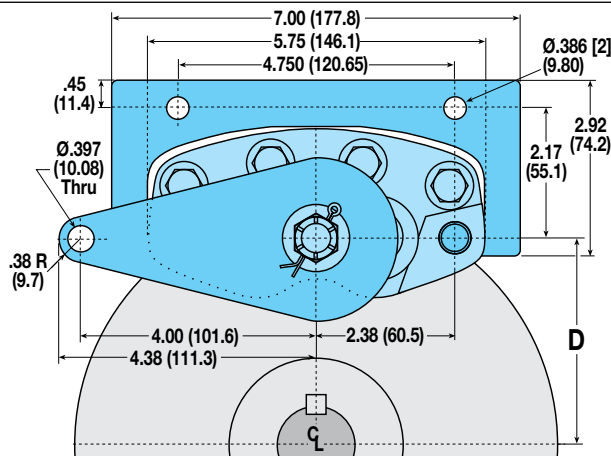

## MB3 SERIES - CAST IRON

### AVAILABLE STYLES

#### Single Acting

FIXED MOUNT - FLOATING DISC



PICTURED: 0790-0000

### MB3 SPECIFICATIONS

Maximum lever force:	660 Lbs.
Accommodates Tolomatic disc diameters:	10", 12", 16"
Maximum disc diameter:	30"
Housing Material:	Cast iron
Bolts:	Zinc plated grade 5
Wearable friction material:	6.06 in <sup>3</sup>
Friction material:	Replaceable, high-grade
Total lining area:	9.69 in <sup>2</sup>
Machined Cam:	Positioning in 60° increments
Lining Wear Adjustment:	One step procedure
Designed to be more efficient and priced lower than competitive brakes	

### CAM TRAVEL DATA

- 0° travel with .500" disc.
- 90° maximum travel after .125" wear on each side of lining without intermediate tightening of the lock nut.

### DISC SIZING EQUATIONS

$$\text{DYNAMIC TORQUE (IN.-LBS.)} = 6.99 \times \text{BRAKING RADIUS (IN.)} \times \text{LEVER FORCE (LBS.)}$$

$$\text{STATIC (PARKING) TORQUE (IN.-LBS.)} = 3.49 \times \text{BRAKING RADIUS (IN.)} \times \text{LEVER FORCE (LBS.)}$$

$$\text{BRAKING RADIUS (IN.)} = [\text{DISC DIAMETER} \div 2] - 0.688$$

### PERFORMANCE DATA

#### Dynamic Torque vs Lever Force

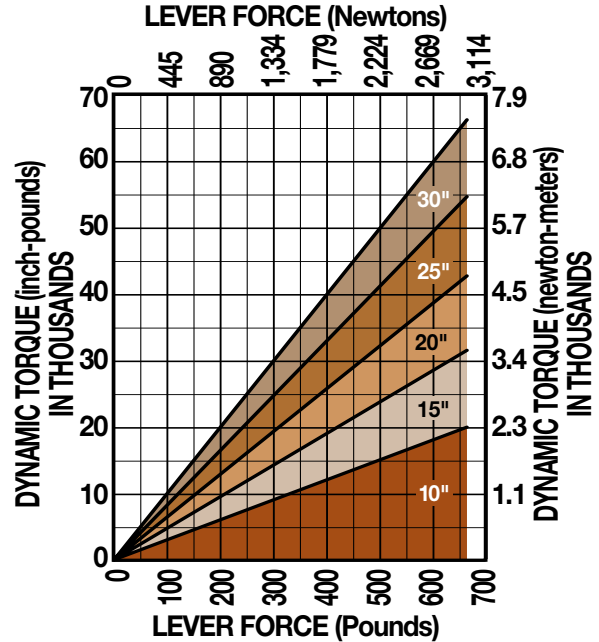

#### Static Torque vs Lever Force

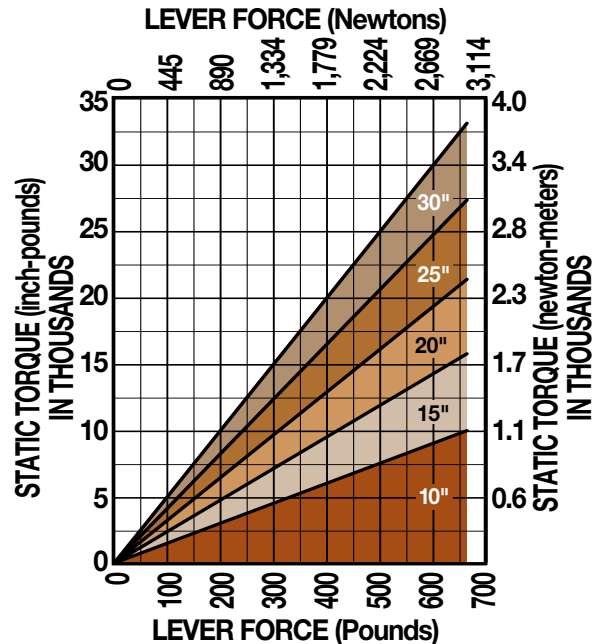

## MB3 SERIES - CAST IRON

### SINGLE ACTING

FIXED MOUNT - FLOATING DISC

Accommodates disc thickness: 1/2"

Weight 13.2 lbs. 5.99 kgs.

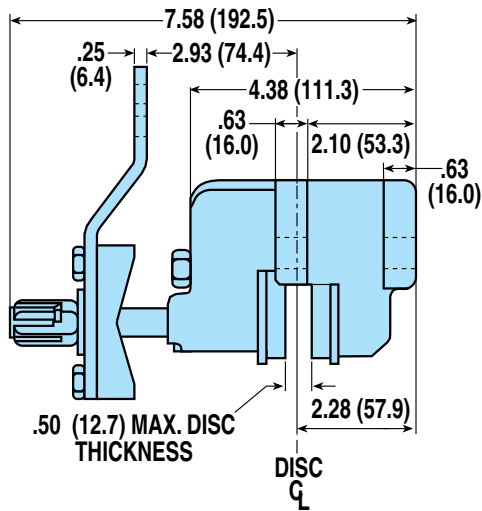

MODEL CODE	DISC THK.	OPTIONS / DESCRIPTION	ASSEMBLY NUMBER
MB3	1/2"	Mechanical Brake	0790-0000

### MOUNTING DIMENSIONS

Disc Diameter	10"	15"	20"	25"	30"
<b>A</b>	5.50"	8.00"	10.50"	13.00"	15.50"
Braking Radius	4.09"	6.59"	9.09"	11.59"	14.09"

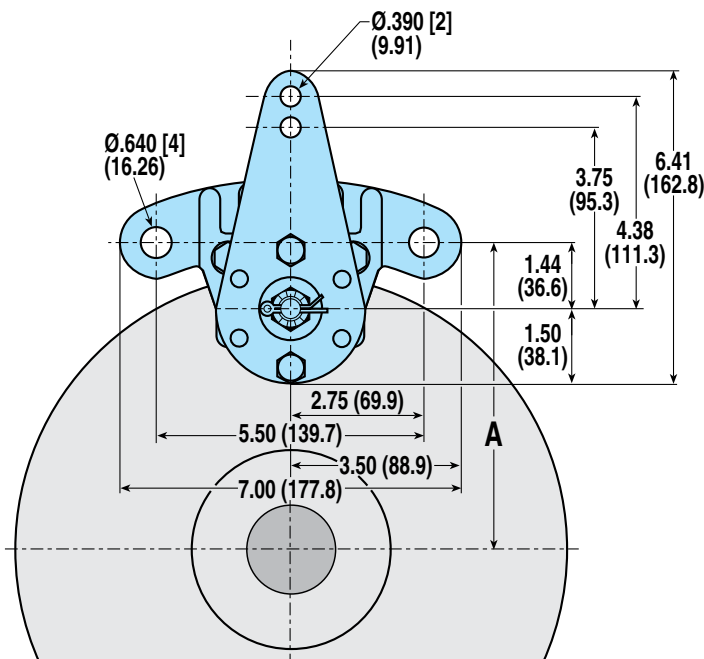



## FS20 SERIES - ALUMINUM

### AVAILABLE STYLES

**Single Acting -  
Hydraulically Released**

FLOATING MOUNT - FIXED DISC



PICTURED: 0760-0000

**Single Acting -  
Pneumatically Released**

FLOATING MOUNT - FIXED DISC



PICTURED: 0760-0016

### FS20 SPECIFICATIONS

Maximum hydraulic pressure:	1,500 PSI non shock
Maximum pneumatic pressure:	100 PSI non shock
Minimum hydraulic pressure to release brake:	750 PSI
Minimum pneumatic pressure to release brake:	80 PSI (FS20P only)
Accommodates Tolomatic disc diameters:	6-5/16", 8", 10", 12", 16"
Maximum disc diameter:	none
Housing Material:	Die cast aluminum
Bolts:	Zinc plated grade 8
Seals:	Buna-N Standard
Wearable friction material, hydraulic:	.53 in <sup>3</sup>
Wearable friction material, pneumatic:	.24 in <sup>3</sup>
Friction material:	Replaceable, high-grade
Total lining area:	3.8 in <sup>2</sup>
Floating bracket:	Standard
Fluid displacement, hydraulic:	0.056 in <sup>3</sup>
Fluid displacement, pneumatic:	0.359 in <sup>3</sup>

### OPTIONS

Seals: EPR seals

### BRAKE MODEL LETTER CODES

<b>A</b> 5/32" Thick Disc	<b>FS</b> Spring Applied	<b>P</b> Pneumatically Released
<b>B</b> 1/4" Thick Disc	<b>G</b> EPR Seals	

### DISC SIZING EQUATIONS

STATIC (PARKING) TORQUE (IN.-LBS.) = TANGENTIAL FORCE (LBS.) x BRAKING RADIUS (IN.)  
 BRAKING RADIUS (IN.) = [DISC DIAMETER ÷ 2] - 0.875

### PERFORMANCE DATA

**\*Hydraulic Static Torque vs Lining Wear**

\*For pneumatically released units (FS20P) see Disc Sizing Equations below

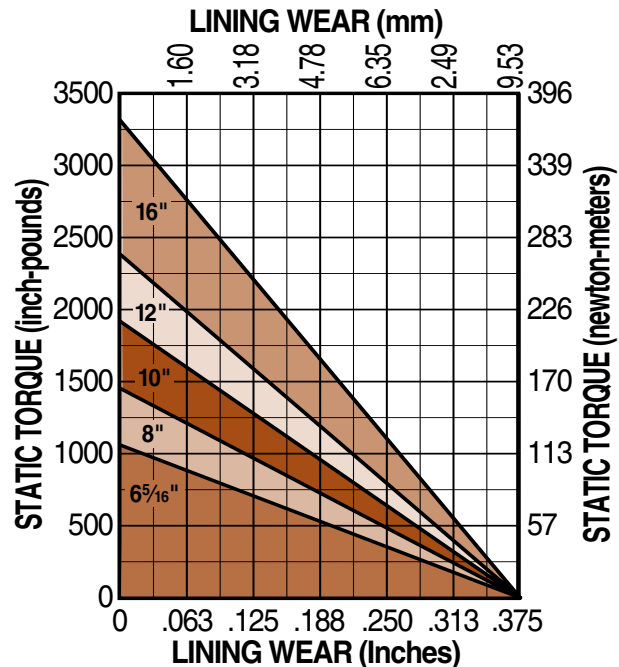

### Tangential Force

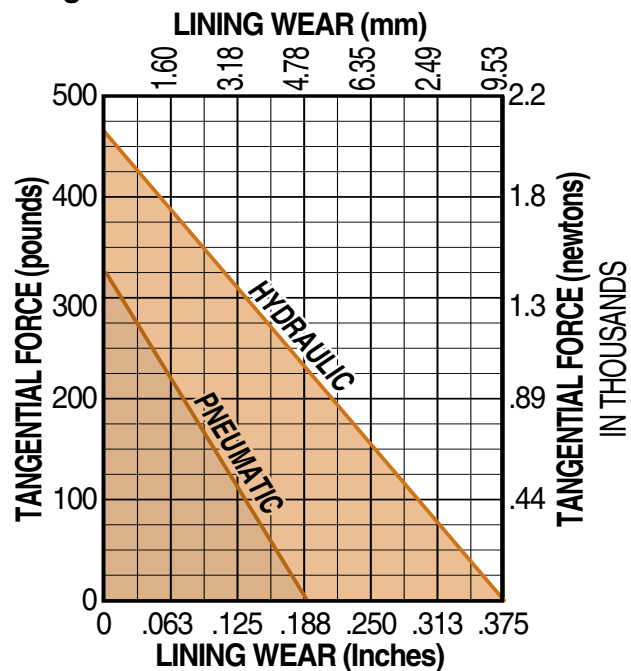

## FS20 SERIES - ALUMINUM

### SINGLE ACTING WITH FLOATING BRACKET - HYDRAULICALLY RELEASED FLOATING MOUNT - FIXED DISC

Accommodates disc thickness: 5/32" 1/4"

Weight 4.0 lbs. 1.81 kgs.

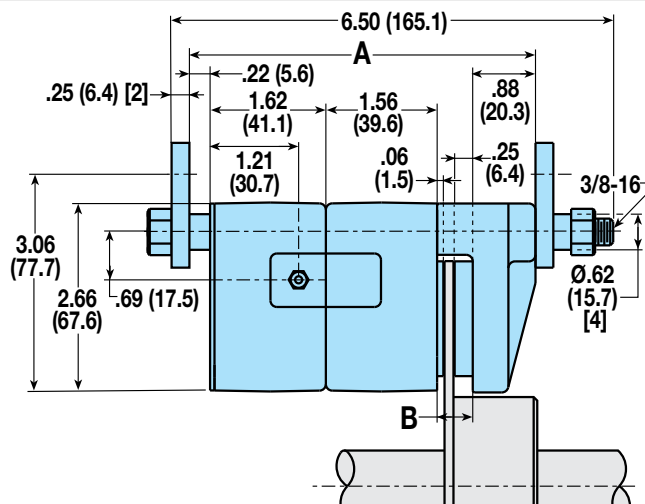

MODEL CODE	DISC THK.	A	B	OPTIONS / DESCRIPTION	ASSEMBLY NUMBER
FS20A	5/32"	4.78"	.500"	Spring Applied	0760-0000
FS20AG	5/32"	4.78"	.500"	Spring Applied, EPR Seals	0760-0003
FS20B	1/4"	4.87"	.594"	Spring Applied	0760-0001
FS20BG	1/4"	4.87"	.594"	Spring Applied, EPR Seals	0760-0004

### MOUNTING DIMENSIONS

Disc Diameter		6.313"	8"	10"	12"	16"
Braking Radius	<b>C</b>	2.281"	3.125"	4.125"	5.125"	7.125"
	<b>D</b>	4.344"	5.188"	6.188"	7.188"	9.188"

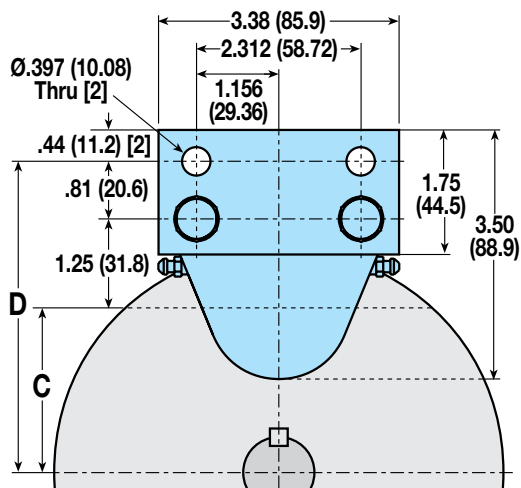

### SINGLE ACTING WITH FLOATING BRACKET - PNEUMATICALLY RELEASED FLOATING MOUNT - FIXED DISC

Accommodates disc thickness: 5/32" 1/4"

Weight 7.75 lbs. 3.52 kgs.

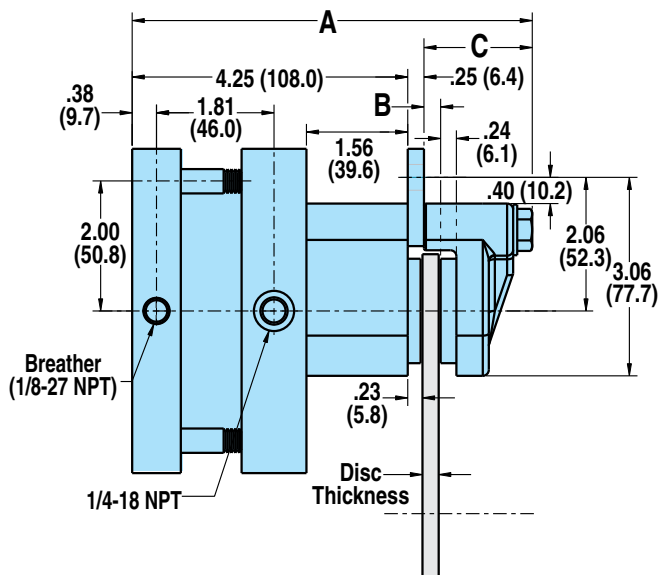

MODEL CODE	DISC THK.	A	B	C	OPTIONS / DESCRIPTION	ASSEMBLY NUMBER
FS20PA	5/32"	6.09"	.16"	1.59"	Spring Applied	0760-0023
FS20PB	1/4"	6.18"	.26"	1.68"	Spring Applied	0760-0016

### MOUNTING DIMENSIONS

Disc Diameter		6.313"	8"	10"	12"	16"
Braking Radius	<b>D</b>	2.281"	3.125"	4.125"	5.125"	7.125"
	<b>E</b>	4.281"	5.125"	6.125"	7.125"	9.125"

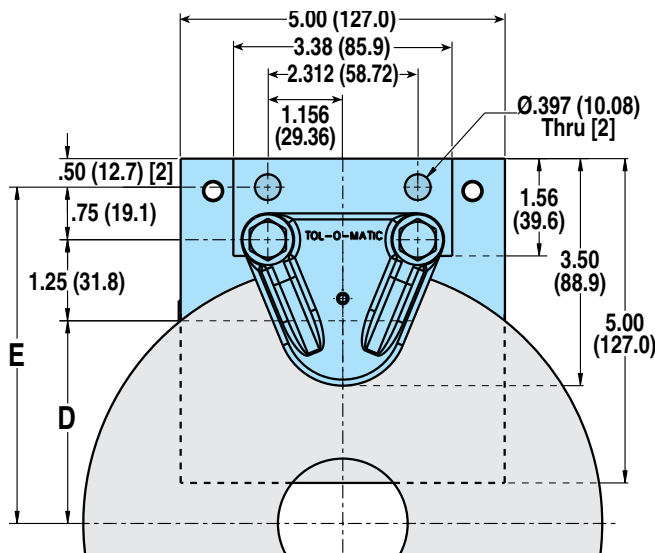

## FS220B SERIES - ALUMINUM

### AVAILABLE STYLES

**Single Acting - B - 750 PSI Release**  
FLOATING MOUNT - FIXED DISC



PICTURED: 0740-0000

### FS220B SPECIFICATIONS

Maximum hydraulic pressure:	2,000 PSI non shock
Minimum hydraulic pressure to release brake:	750 PSI
Accommodates Tolomatic disc diameters:	6-5/16", 8", 10", 12", 16"
Maximum disc diameter:	16"
Housing Material:	Die cast aluminum
Bolts:	Zinc plated grade 8
Seals:	Buna-N Standard
Wearable friction material:	1.6 in <sup>3</sup>
Friction material:	Replaceable, high-grade
Total lining area:	7.5 in <sup>2</sup>
Floating bracket:	Standard
Fluid displacement:	0.113 in <sup>3</sup>

### BRAKE MODEL LETTER CODES

<b>A</b> 5/32" Thick Disc	<b>E</b> 1/2" Thick Disc	<b>L</b> 3/8" Thick Disc
<b>B</b> 1/4" Thick Disc	<b>FS</b> Spring Applied	

### DISC SIZING EQUATIONS

STATIC (PARKING) TORQUE (IN.-LBS.) = TANGENTIAL FORCE (LBS.) x BRAKING RADIUS (IN.)

### PERFORMANCE DATA

#### Static Torque vs Lining Wear

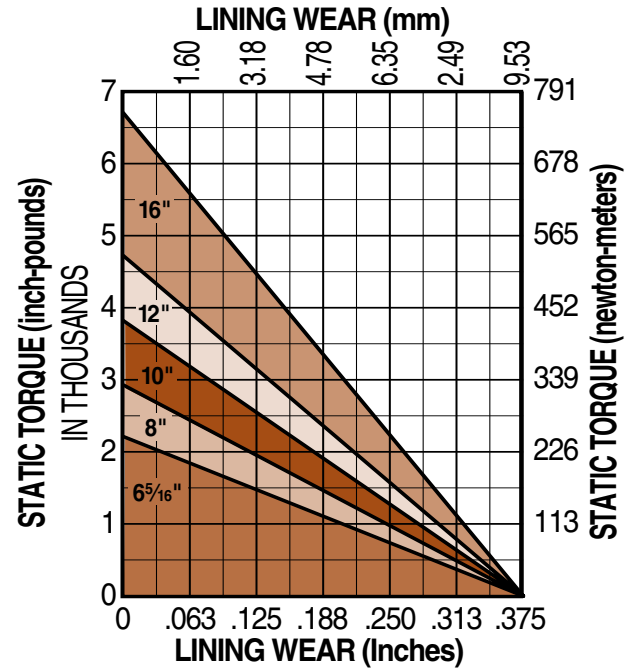

#### Tangential Force

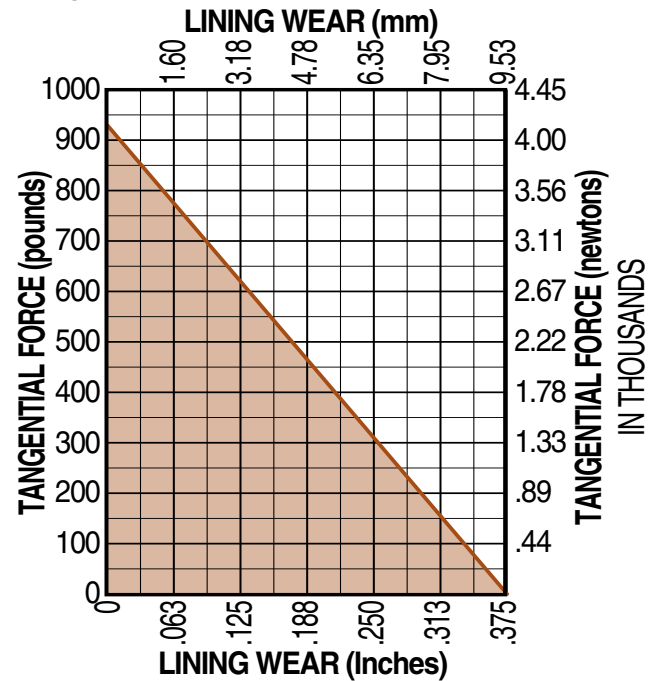

## FS220B SERIES - ALUMINUM

### SINGLE ACTING WITH FLOATING BRACKET

#### FLOATING MOUNT - FIXED DISC

Accommodates disc thickness: 5/32" 1/4" 3/8" 1/2"

Weight 8.0 lbs. 3.63 kgs.

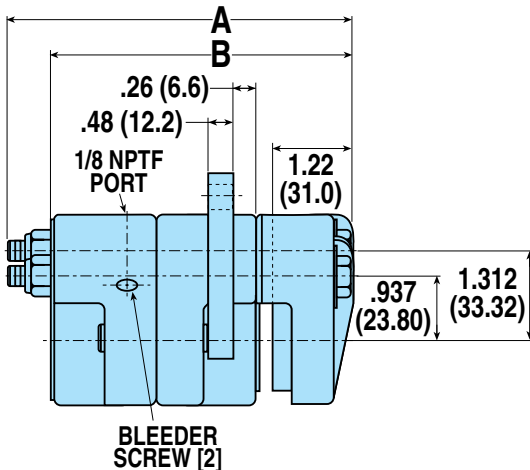

MODEL CODE	DISC THK.	A	B	OPTIONS / DESCRIPTION	ASSEMBLY NUMBER
FS220BA	5/32"	5.31"	4.56"	Floating Bracket, "B" Strength	0740-0000
FS220BB	1/4"	5.31"	4.65"	Floating Bracket, "B" Strength	0740-0017
FS220BL	3/8"	5.81"	4.78"	Floating Bracket, "B" Strength	0740-0019
FS220BE	1/2"	5.81"	4.90"	Floating Bracket, "B" Strength	0740-0021

### MOUNTING DIMENSIONS

Disc Diameter	6.313"	8"	10"	12"	16"
Braking Radius	2.38"	3.15"	4.11"	5.08"	7.21"
<b>C</b>	4.30"	5.17"	6.17"	7.17"	9.17"
<b>D</b>	3.45"	4.32"	5.32"	6.32"	8.41"
<b>E</b>	3.07"	3.94"	4.94"	5.94"	8.03"
<b>F</b>	2.13"	3.00"	4.00"	5.00"	7.09"

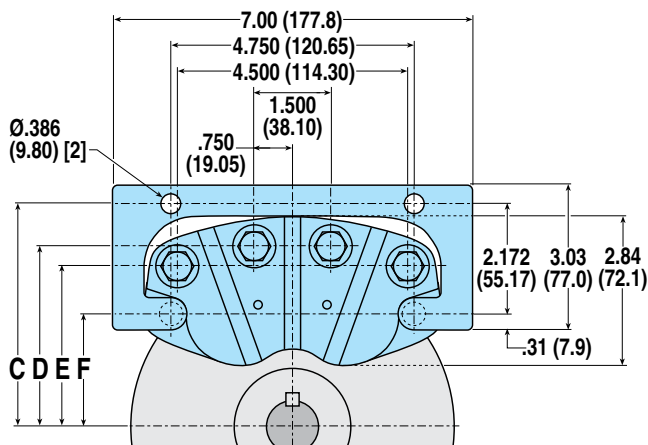

## FS220C SERIES - ALUMINUM

### AVAILABLE STYLES

**Single Acting - C - 1500 PSI Release**  
FLOATING MOUNT - FIXED DISC



PICTURED: 0741-0000

### FS220C SPECIFICATIONS

Maximum hydraulic pressure:	2,000 PSI non shock
Minimum hydraulic pressure to release brake:	1500 PSI
Accommodates Tolomatic disc diameters:	6-5/16", 8", 10", 12", 16"
Maximum disc diameter:	16"
Housing Material:	Die cast aluminum
Bolts:	Zinc plated grade 8
Seals:	Buna-N Standard
Wearable friction material:	1.6 in <sup>3</sup>
Friction material:	Replaceable, high-grade
Total lining area:	7.5 in <sup>2</sup>
Floating bracket:	Standard
Fluid displacement:	0.113 in <sup>3</sup>

### BRAKE MODEL LETTER CODES

<b>A</b> 5/32" Thick Disc	<b>E</b> 1/2" Thick Disc	<b>L</b> 3/8" Thick Disc
<b>B</b> 1/4" Thick Disc	<b>FS</b> Spring Applied	

### PERFORMANCE DATA

#### Static Torque vs Lining Wear

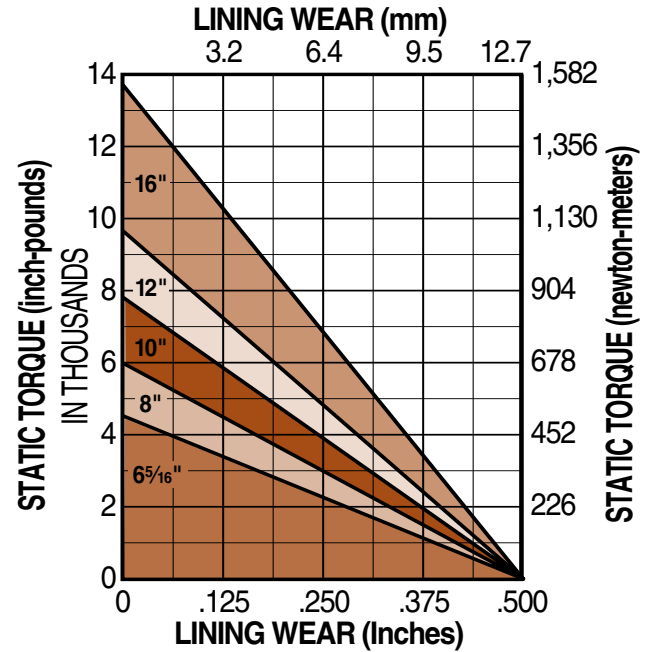

#### Tangential Force

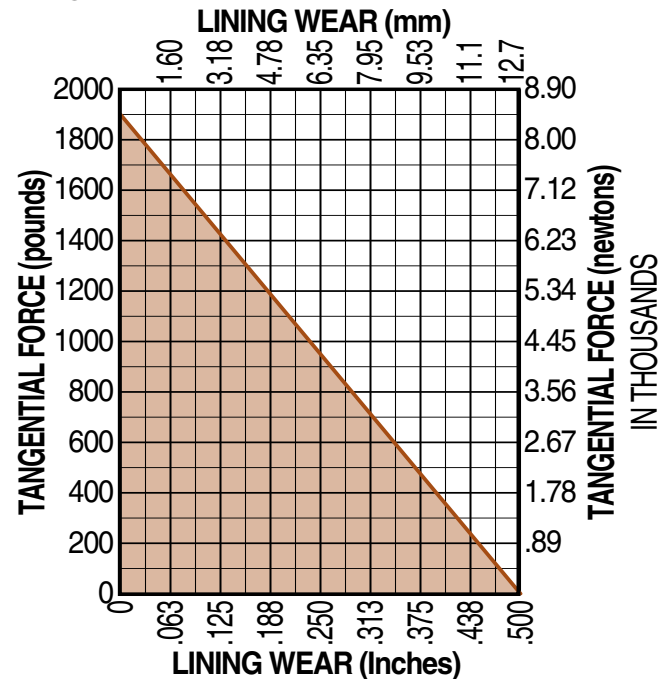

### DISC SIZING EQUATIONS

STATIC (PARKING) TORQUE (IN.-LBS.) = TANGENTIAL FORCE (LBS.) x BRAKING RADIUS (IN.)



## FS220C SERIES - ALUMINUM

### SINGLE ACTING WITH FLOATING BRACKET

#### FLOATING MOUNT - FIXED DISC

Accommodates disc thickness: 5/32" 1/4" 3/8" 1/2"

Weight 8.0 lbs. 3.63 kgs.

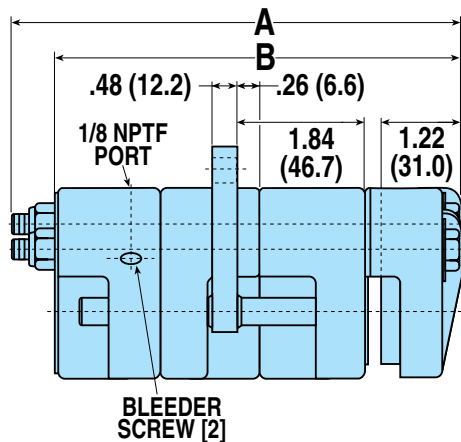

MODEL CODE	DISC THK.	A	B	OPTIONS / DESCRIPTION	ASSEMBLY NUMBER
FS220CA	5/32"	6.81"	6.16"	Floating Bracket, "C" Strength	0741-0000
FS220CB	1/4"	6.81"	6.25"	Floating Bracket, "C" Strength	0741-0018
FS220CL	3/8"	7.31"	6.38"	Floating Bracket, "C" Strength	0741-0020
FS220CE	1/2"	7.31"	6.50"	Floating Bracket, "C" Strength	0741-0022

### MOUNTING DIMENSIONS

Disc Diameter	6.313"	8"	10"	12"	16"
Braking Radius	2.38"	3.15"	4.11"	5.08"	7.21"
<b>C</b>	4.30"	5.17"	6.17"	7.17"	9.17"
<b>D</b>	3.45"	4.32"	5.32"	6.32"	8.41"
<b>E</b>	3.07"	3.94"	4.94"	5.94"	8.03"
<b>F</b>	2.13"	3.00"	4.00"	5.00"	7.09"

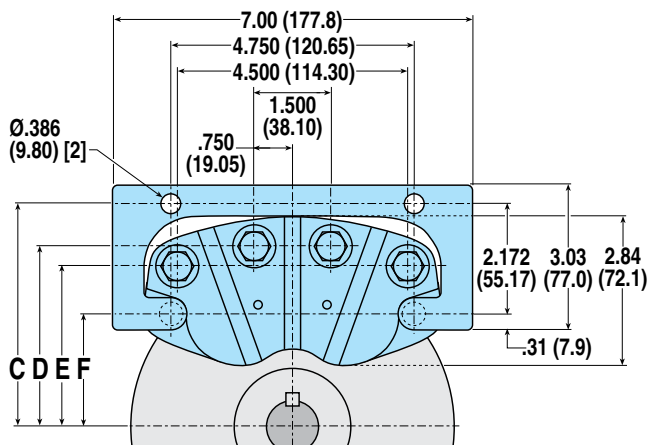

## FS220BI SERIES - DUCTILE IRON

### AVAILABLE STYLES

**Single Acting - B - 750 PSI Release**

FLOATING MOUNT - FIXED DISC



PICTURED: 0740-0001

### FS220BI SPECIFICATIONS

Maximum hydraulic pressure:	2,000 PSI non shock
Minimum hydraulic pressure to release brake:	750 PSI
Accommodates Tolomatic disc diameters:	6-5/16", 8", 10", 12", 16"
Maximum disc diameter:	16"
Housing Material:	Cast ductile iron
Bolts:	Zinc plated grade 8
Seals:	Buna-N Standard
Wearable friction material:	2.7 in <sup>3</sup>
Friction material:	Replaceable, high-grade
Total lining area:	9.6 in <sup>2</sup>
Floating bracket:	Standard
Fluid displacement:	0.113 in <sup>3</sup>
Recommended wear compensation interval:	.06 in. lining wear

### BRAKE MODEL LETTER CODES

<b>A</b> 5/32" Thick Disc	<b>FS</b> Spring Applied	<b>K</b> Manual Compensator
<b>B</b> 1/4" Thick Disc	<b>I</b> Iron	<b>L</b> 3/8" Thick Disc
<b>E</b> 1/2" Thick Disc	<b>J</b> Manual Retractor	

### DISC SIZING EQUATIONS

STATIC (PARKING) TORQUE (IN.-LBS.) = TANGENTIAL FORCE (LBS.) x BRAKING RADIUS (IN.)

### PERFORMANCE DATA

#### Static Torque vs Lining Wear

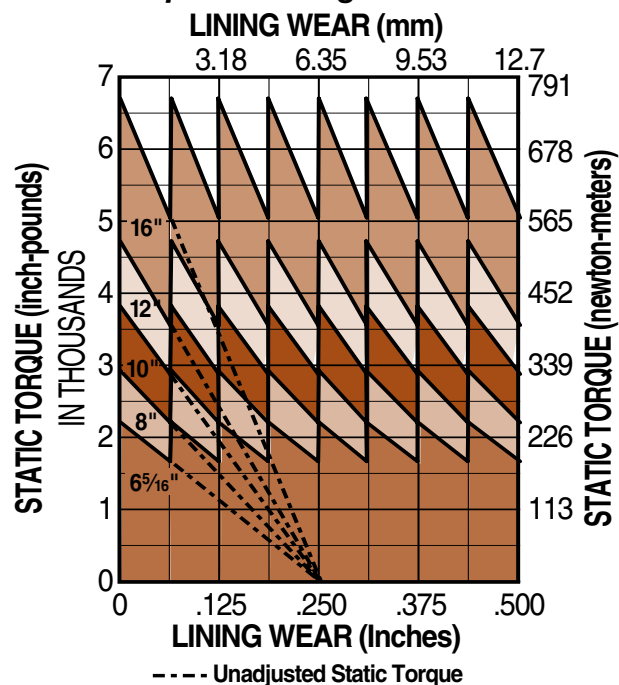

#### Tangential Force

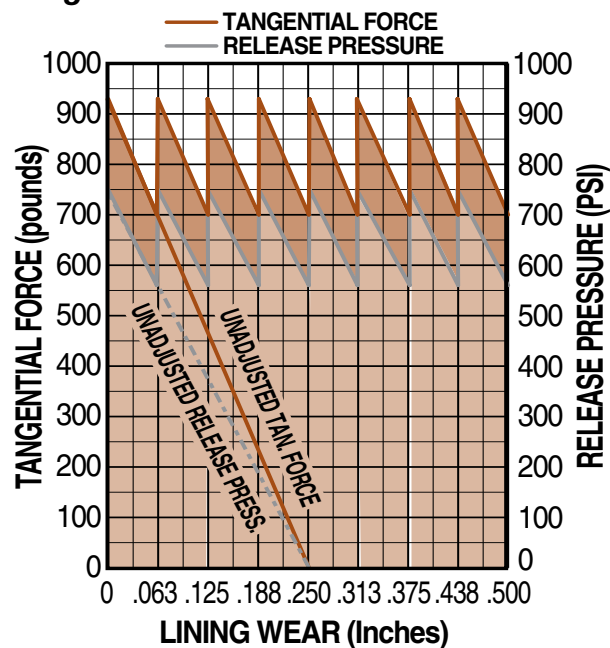

## FS220BI SERIES - DUCTILE IRON

### SINGLE ACTING WITH FLOATING BRACKET

#### FLOATING MOUNT - FIXED DISC

Accommodates disc thickness: 5/32" 1/4" 3/8" 1/2"

Weight 14.5 lbs. 6.58 kgs.

#### STANDARD MODELS

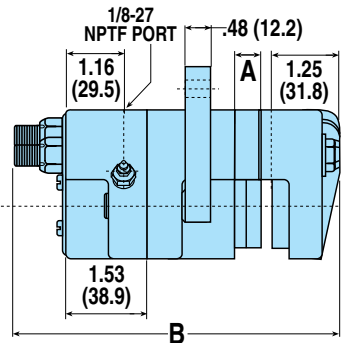

#### JK OPTION MODELS

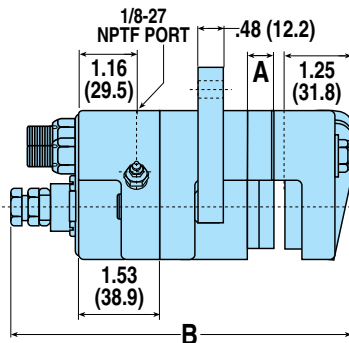

MODEL CODE	DISC THK.	A	B	OPTIONS / DESCRIPTION	ASSEMBLY NUMBER
FS220BIA	5/32"	—	5.27"	Floating Bracket, "B" Strength	0740-0001
FS220BIB	1/4"	.093"	5.77"	Floating Bracket, "B" Strength	0740-0003
FS220BIL	3/8"	.218"	5.77"	Floating Bracket, "B" Strength	0740-0004
FS220BIE	1/2"	.344"	5.77"	Floating Bracket, "B" Strength	0740-0005
FS220BIAJK	5/32"	.500"	6.32"	Ftg Bkt, "B" Stgh, ManRet, ManComp	0740-0006
FS220BIBJK	1/4"	.594"	6.42"	Ftg Bkt, "B" Stgh, ManRet, ManComp	0740-0007
FS220BILJK	3/8"	.718"	6.54"	Ftg Bkt, "B" Stgh, ManRet, ManComp	0740-0008
FS220BIEJK	1/2"	.844"	6.67"	Ftg Bkt, "B" Stgh, ManRet, ManComp	0740-0009

### MOUNTING DIMENSIONS

Disc Diameter	6.313"	8"	10"	12"	16"
Braking Radius	2.38"	3.15"	4.11"	5.08"	7.21"
<b>C</b>	4.30"	5.17"	6.17"	7.17"	9.17"
<b>D</b>	3.45"	4.32"	5.32"	6.32"	8.41"
<b>E</b>	3.07"	3.94"	4.94"	5.94"	8.03"
<b>F</b>	2.13"	3.00"	4.00"	5.00"	7.09"

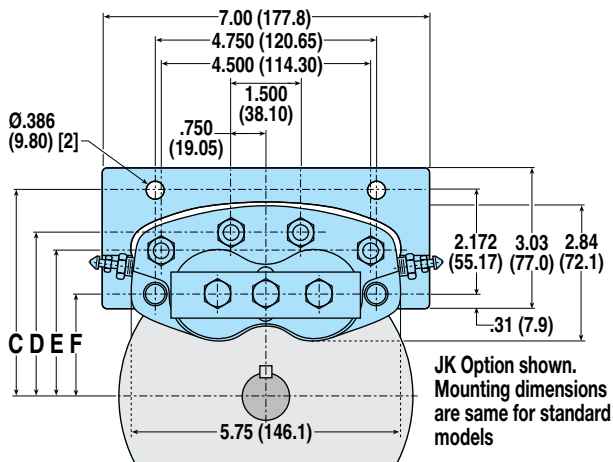

## FS220CI SERIES - DUCTILE IRON

### AVAILABLE STYLES

**Single Acting - C - 1500 PSI Release**  
FLOATING MOUNT - FIXED DISC



PICTURED: 0741-0009 (Shown with JK Option)

### FS220CI SPECIFICATIONS

Maximum hydraulic pressure:	2,000 PSI non shock
Minimum hydraulic pressure to release brake:	1500 PSI
Accommodates Tolomatic disc diameters:	6-5/16", 8", 10", 12", 16"
Maximum disc diameter:	16"
Housing Material:	Cast ductile iron
Bolts:	Zinc plated grade 8
Seals:	Buna-N Standard
Wearable friction material:	2.7 in <sup>3</sup>
Friction material:	Replaceable, high-grade
Total lining area:	9.6 in <sup>2</sup>
Floating bracket:	Standard
Fluid displacement:	0.113 in <sup>3</sup>
Recommended wear compensation interval:	.10 in. lining wear

### BRAKE MODEL LETTER CODES

<b>A</b> 5/32" Thick Disc	<b>FS</b> Spring Applied	<b>K</b> Manual Compensator
<b>B</b> 1/4" Thick Disc	<b>I</b> Iron	<b>L</b> 3/8" Thick Disc
<b>E</b> 1/2" Thick Disc	<b>J</b> Manual Retractor	

### PERFORMANCE DATA

#### Static Torque vs Lining Wear

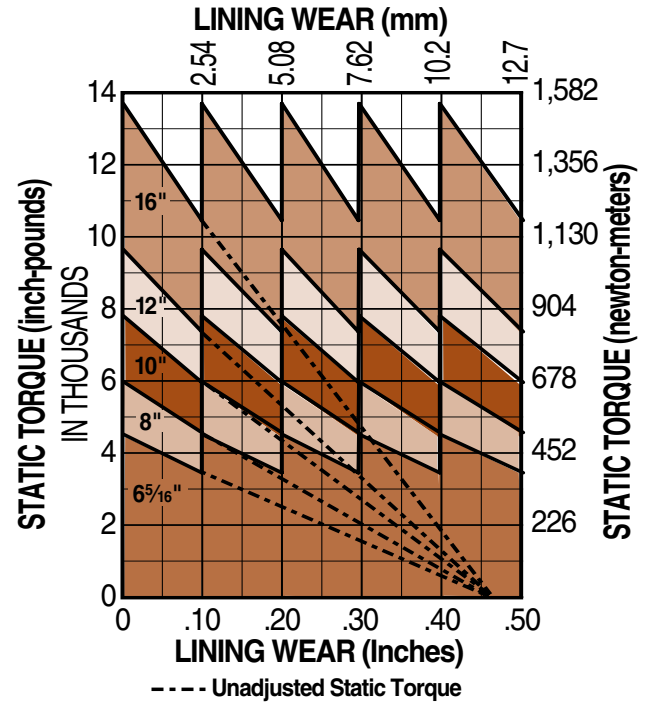

#### Tangential Force

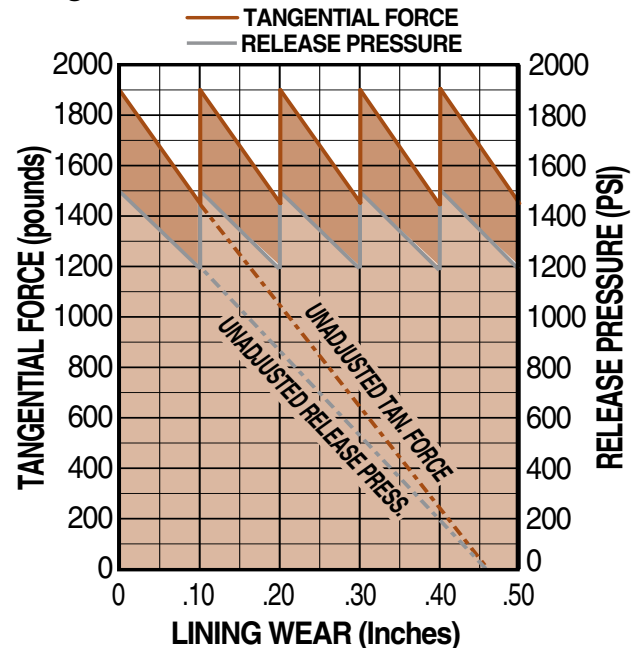

### DISC SIZING EQUATIONS

STATIC (PARKING) TORQUE (IN.-LBS.) = TANGENTIAL FORCE (LBS.) x BRAKING RADIUS (IN.)

- FEATURES
- APPLICATIONS
- SELECTION GRAPHS
- PNEUMATIC BRAKES
- P10
- P20
- P220
- HYDRAULIC BRAKES
- H10
- H20
- H220
- H220I
- H441
- H960
- HYDRAULIC/MECHANICAL BRAKE COMBOS
- H/ME20
- H/ME220
- MECHANICAL BRAKES
- ME10
- ME20
- ME220
- MB3
- SPRING APPLIED BRAKES
- FS20
- FS220
- FS220I
- FS395
- DISCS HUBS & BUSHINGS
- TENSION CONTROL COMBINATIONS
- INTENSIFIER
- SELECTION WORKSHEET

## FS220CI SERIES - DUCTILE IRON

### SINGLE ACTING WITH FLOATING BRACKET

#### FLOATING MOUNT - FIXED DISC

Accommodates disc thickness: 5/32" 1/4" 3/8" 1/2"

Weight 20.0 lbs. 9.07 kgs.

#### STANDARD MODELS

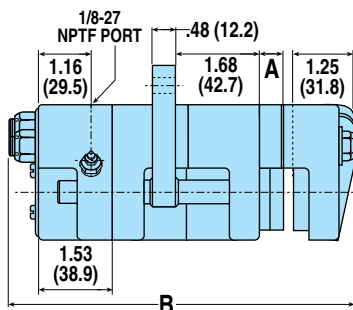

#### JK OPTION MODELS

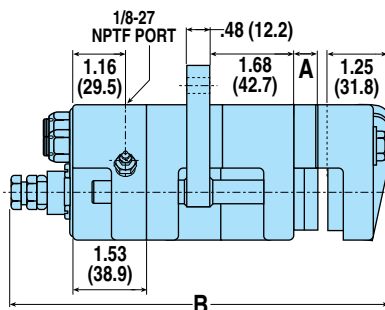

MODEL CODE	DISC THK.	A	B	OPTIONS / DESCRIPTION	ASSEMBLY NUMBER
FS220CIA	5/32"	—	6.77"	Floating Bracket, "C" Strength	0741-0005
FS220CIB	1/4"	.093"	6.77"	Floating Bracket, "C" Strength	0741-0006
FS220CIL	3/8"	.218"	7.27"	Floating Bracket, "C" Strength	0741-0007
FS220CIE	1/2"	.344"	7.27"	Floating Bracket, "C" Strength	0741-0008
FS220CIAJK	5/32"	.562"	7.96"	Ftg Bkt, "C" Stgh, ManRet, ManComp	0741-0009
FS220CIBJK	1/4"	.656"	8.06"	Ftg Bkt, "C" Stgh, ManRet, ManComp	0741-0010
FS220CILJK	3/8"	.780"	8.18"	Ftg Bkt, "C" Stgh, ManRet, ManComp	0741-0011
FS220CIEJK	1/2"	.906"	8.32"	Ftg Bkt, "C" Stgh, ManRet, ManComp	0741-0012

### MOUNTING DIMENSIONS

Disc Diameter	6.313"	8"	10"	12"	16"
Braking Radius	2.38"	3.15"	4.11"	5.08"	7.21"
<b>C</b>	4.30"	5.17"	6.17"	7.17"	9.17"
<b>D</b>	3.45"	4.32"	5.32"	6.32"	8.41"
<b>E</b>	3.07"	3.94"	4.94"	5.94"	8.03"
<b>F</b>	2.13"	3.00"	4.00"	5.00"	7.09"

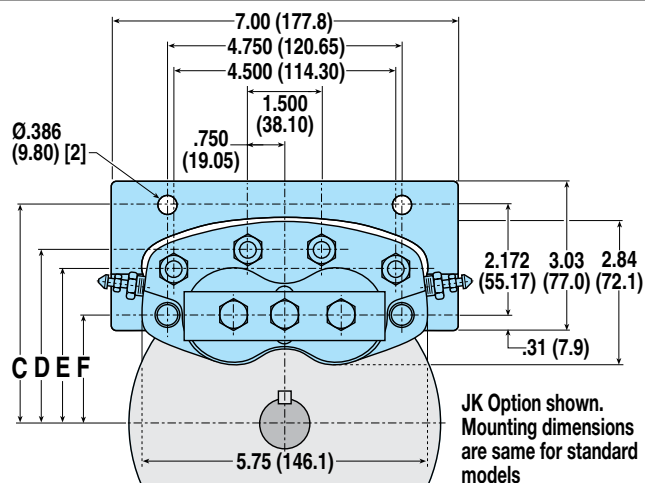



## FS595 SERIES - DUCTILE IRON

### AVAILABLE STYLES

#### Double Acting

FLOATING MOUNT - FIXED DISC



PICTURED: 0781-0000

### FS595 SPECIFICATIONS

Maximum hydraulic pressure:	2,000 PSI non shock
Minimum hydraulic pressure to release brake:	1,400 PSI
Accommodates Tolomatic disc diameters:	16"
Minimum disc diameter:	14"
Maximum disc diameter:	none
Housing Material:	Cast ductile iron
Bolts:	Zinc plated grade 8
Seals:	Buna-N Standard
Wearable friction material:	3.43 in <sup>3</sup>
Friction material:	Replaceable, high-grade
Total lining area:	9.14 in <sup>2</sup>
Fluid displacement for .03 inch clearance:	0.230 in <sup>3</sup>
Recommended wear compensation interval:	.25 in. lining wear

### OPTIONS

Seals:	Viton® seals
Adaptable to thinner discs:	Consult factory

### BRAKE MODEL LETTER CODES

<b>C</b> With Bleeder Fittings	<b>FS</b> Spring Applied	<b>O</b> 1-1/4" Thick Disc
<b>D</b> Double Acting	<b>I</b> Iron	<b>Q</b> 1-1/2" Thick Disc
<b>E</b> 1/2" Thick Disc	<b>K</b> Manual Compensator	<b>V</b> Viton® Seals

### DISC SIZING EQUATIONS

STATIC (PARKING) TORQUE (IN.-LBS.) = TANGENTIAL FORCE (LBS.) x BRAKING RADIUS (IN.)  
 BRAKING RADIUS (IN.) = [DISC DIAMETER ÷ 2] - 1.280

### PERFORMANCE DATA

#### Static Torque vs Lining Wear

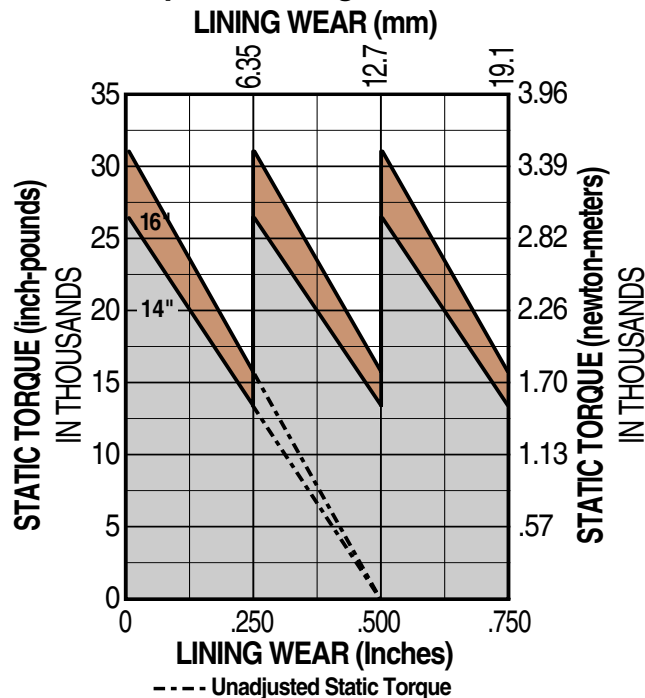

#### Tangential Force

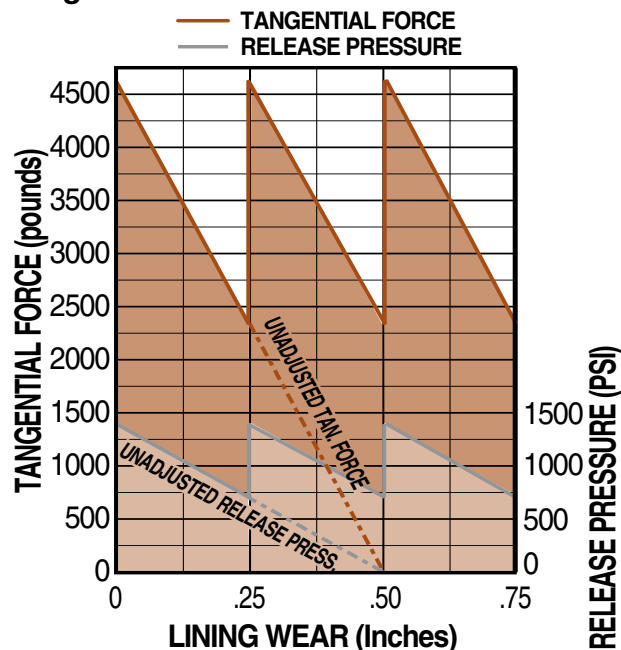

## FS595 SERIES - DUCTILE IRON

### DOUBLE ACTING FIXED MOUNT - FIXED DISC

Accommodates disc thickness: 1/2" 1-1/4" 1-1/2"

Weight 36.0 lbs. 16.33 kgs.

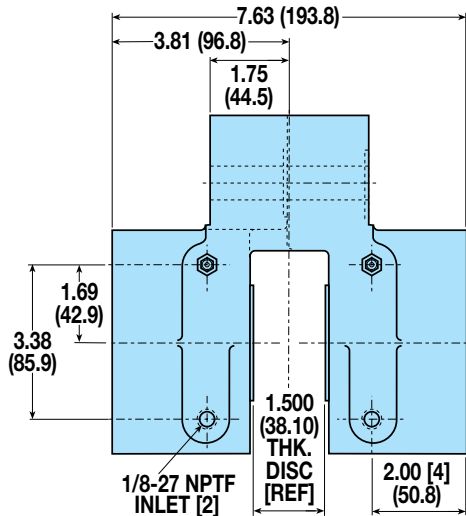

MODEL CODE	DISC THK.	OPTIONS / DESCRIPTION	ASSEMBLY NUMBER
FS595DCIKE	1/2"	Double Acting, Iron, Man Wear Comp	0781-0011
FS595DCIKO	1-1/4"	Double Acting, Iron, Man Wear Comp	0781-0018
FS595DCIKQ	1-1/2"	Double Acting, Iron, Man Wear Comp	0781-0000
FS595DCIKQV	1-1/2"	Dbi Act, Iron, Man Comp, Viton® Seals	0781-0001

### MOUNTING DIMENSIONS

Disc Diameter	14"	16"
A	9.16"	10.16"
Braking Radius	B 5.72"	6.72"

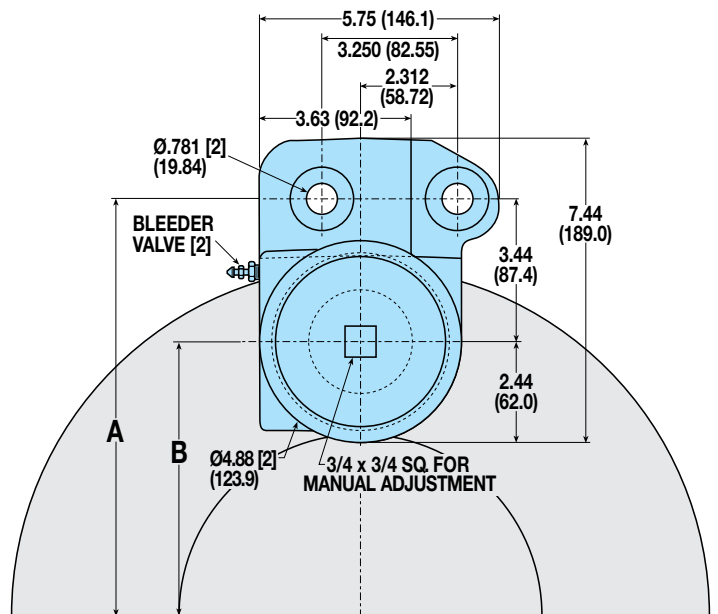

Viton® is a registered trademark of the E.I. Du Pont de Nemours Co., [www.dupont.com](http://www.dupont.com)

SEE NEXT PAGE FOR FS595 DUAL

## FS595 DUAL SERIES - DUCTILE IRON

### AVAILABLE STYLES

#### Double Acting

FLOATING MOUNT - FIXED DISC



PICTURED: 0782-0003

### FS595 DUAL SPECIFICATIONS

Maximum hydraulic pressure:	2,000 PSI non shock
Minimum hydraulic pressure to release brake:	1,400 PSI
Accommodates Tolomatic disc diameters:	16"
Minimum disc diameter:	14"
Maximum disc diameter:	none
Housing Material:	Cast ductile iron
Bolts:	Zinc plated grade 8
Seals:	Buna-N Standard
Wearable friction material:	6.86 in <sup>3</sup>
Friction material:	Replaceable, high-grade
Total lining area:	18.28 in <sup>2</sup>
Fluid displacement for .03 inch clearance:	0.460 in <sup>3</sup>
Recommended wear compensation interval:	.25 in. lining wear

#### OPTIONS

Adaptable to thinner discs: Consult factory

### BRAKE MODEL LETTER CODES

<b>C</b> With Bleeder Fittings	<b>FS</b> Spring Applied	<b>L</b> 3/8" Thick Disc
<b>D</b> Double Acting	<b>I</b> Iron	<b>N</b> 1" Thick Disc
<b>E</b> 1/2" Thick Disc	<b>K</b> Manual Compensator	<b>Q</b> 1-1/2" Thick Disc

### DISC SIZING EQUATIONS

STATIC (PARKING) TORQUE = TANGENTIAL FORCE x BRAKING RADIUS  
 BRAKING RADIUS = [DISC DIAMETER ÷ 2] - 1.280

### PERFORMANCE DATA

#### Static Torque vs Lining Wear

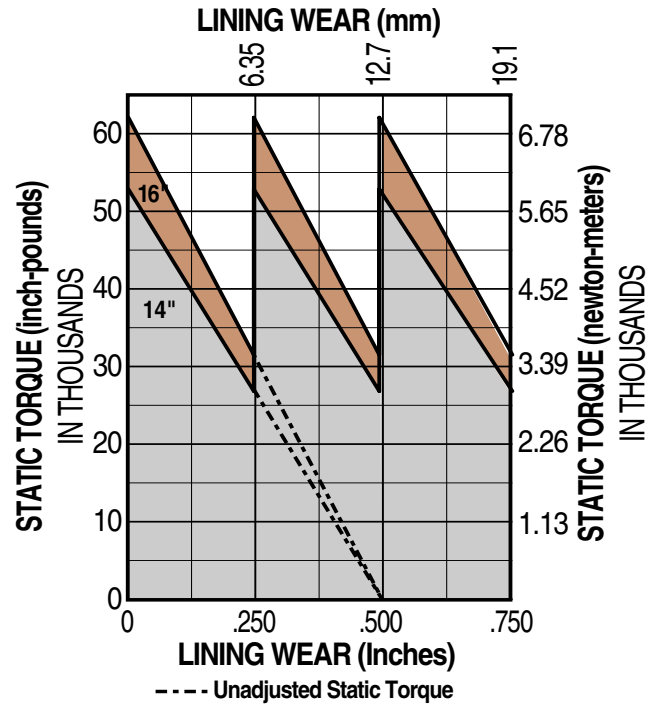

#### Tangential Force

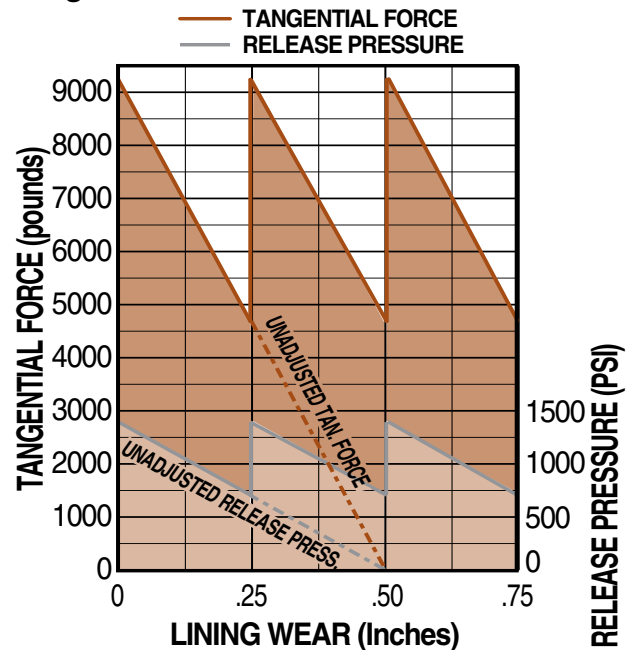

- FEATURES
- APPLICATIONS
- SELECTION GRAPHS
- PNEUMATIC BRAKES
- P10
- P20
- P220
- HYDRAULIC BRAKES
- H10
- H20
- H220
- H220I
- H441
- H960
- HYDRAULIC/MECHANICAL BRAKE COMBOS
- H/ME20
- H/ME220
- MECHANICAL BRAKES
- ME10
- ME20
- ME220
- MB3
- SPRING APPLIED BRAKES
- FS20
- FS220
- FS220I
- FS595
- DISCS, HUBS & BUSHINGS
- TENSION CONTROL COMBINATIONS
- INTENSIFIER
- SELECTION WORKSHEET

## FS595 DUAL SERIES - DUCTILE IRON

### DOUBLE ACTING FIXED MOUNT - FIXED DISC

Accommodates disc thickness: 3/8" 1/2" 1" 1-1/2"

Weight 72.0 lbs. 32.66 kgs.

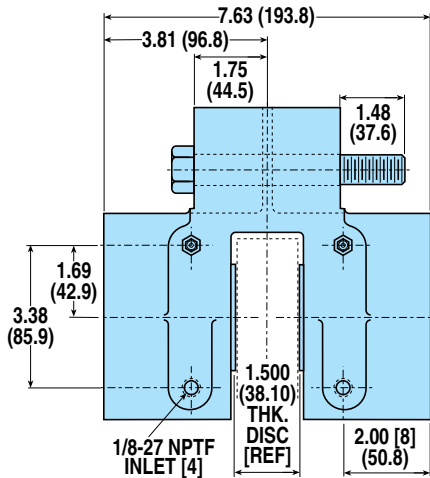

MODEL CODE	DISC THK.	OPTIONS / DESCRIPTION	ASSEMBLY NUMBER
FS595DCIKL-Dual	3/8"	DUAL, Double Acting, Iron, Man Wear Comp	0782-0006
FS595DCIKE-Dual	1/2"	DUAL, Double Acting, Iron, Man Wear Comp	0782-0007
FS595DCIKN-Dual	1"	DUAL, Double Acting, Iron, Man Wear Comp	0782-0008
FS595DCIKQ-Dual	1-1/2"	DUAL, Double Acting, Iron, Man Wear Comp	0782-0003

### MOUNTING DIMENSIONS

Disc Diameter	14"	16"
<b>A</b>	8.58"	9.67"
<b>B</b>	5.23"	6.23"
Braking Radius	<b>C</b> 5.72"	6.72"

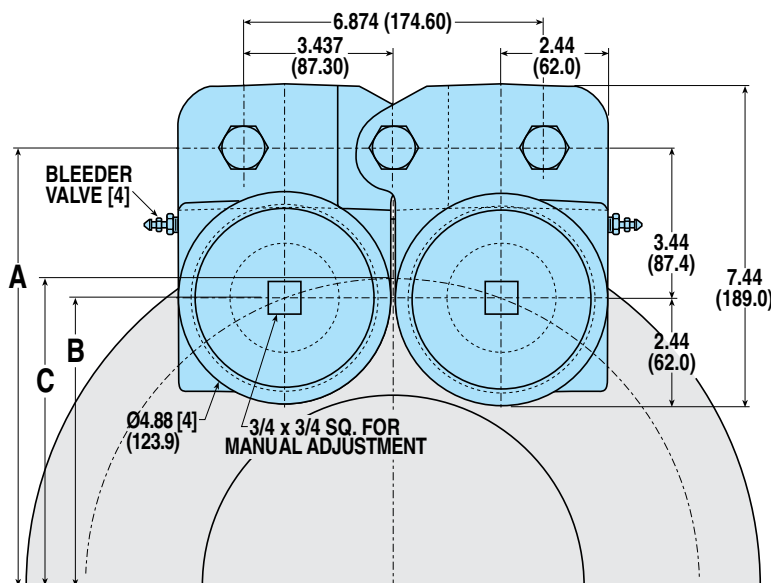

### Top View

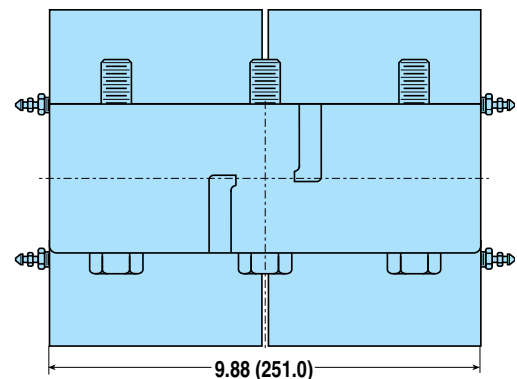

CALIPER  
DISC  
BRAKES

FEATURES

APPLICATIONS

SELECTION  
GRAPHS

PNEUMATIC  
BRAKES

P10

P20

P220

HYDRAULIC  
BRAKES

H10

H20

H220

H220I

H441

H960

HYDRAULIC/  
MECHANICAL  
BRAKE  
COMBOS

H/ME20

H/ME220

MECHANICAL  
BRAKES

ME10

ME20

ME220

MB3

SPRING  
APPLIED  
BRAKES

FS20

FS220

FS220I

FS595

DISCS  
HUBS &  
BUSHINGS

TENSION  
CONTROL  
COMBINATIONS

INTENSIFIER

SELECTION

WORKSHEET

## FIXED HUB & DISC ASSEMBLIES

### AVAILABLE STYLES

#### Hub & Disc Assembly



PICTURED: 0802-0020

### FIXED HUB & DISC SPECIFICATIONS

Disc material:	Carbon 1010 steel
Disc manufacturing details:	Flat within .010 inch, stress relieved and blanchard ground to an 80 (RMS) micro-inch finish
Hub material:	Machined from cold rolled steel
Included fasteners:	Socket head cap screws Keyway set screws

### PERFORMANCE DATA

#### Maximum Power Capacity

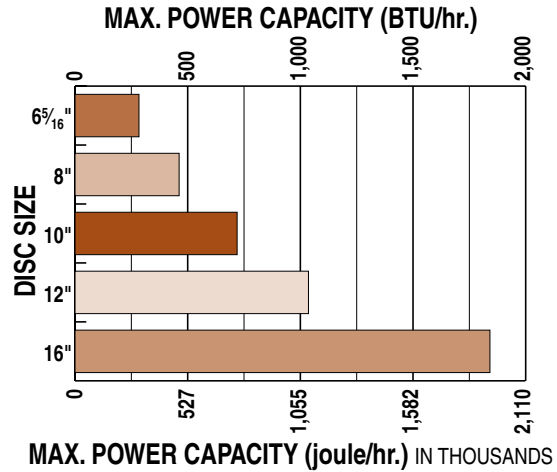

#### Maximum Torque Ratings

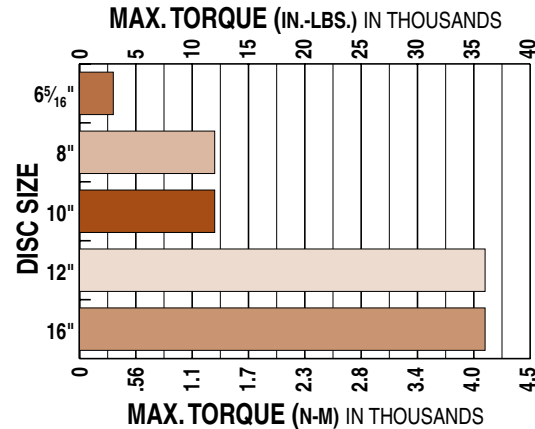

#### Single Stop Maximum Energy

Absorption Capacities\* \*Disc temperature 380° F

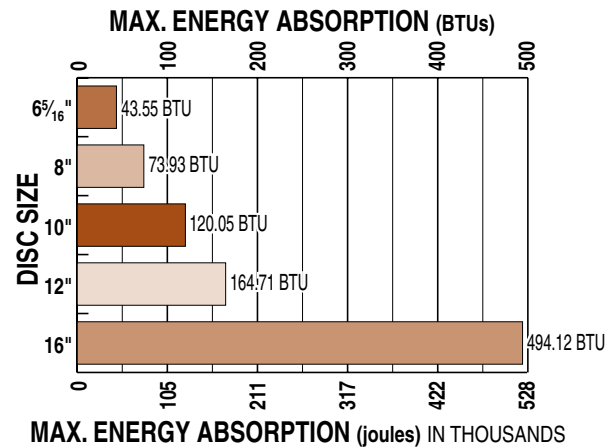

- FEATURES
- APPLICATIONS
- SELECTION GRAPHS
- PNEUMATIC BRAKES
- P10
- P20
- P220
- HYDRAULIC BRAKES
- H10
- H20
- H220
- H220I
- H441
- H960
- HYDRAULIC/MECHANICAL BRAKE COMBOS
- H/ME20
- H/ME220
- MECHANICAL BRAKES
- ME10
- ME20
- ME220
- MB3
- SPRING APPLIED BRAKES
- FS20
- FS220
- FS220I
- FS595
- DISCS HUBS & BUSHINGS
- TENSION CONTROL COMBINATIONS
- INTENSIFIER
- SELECTION WORKSHEET



## FIXED HUB & DISC ASSEMBLIES

### 6<sup>5</sup>/<sub>16</sub>" DISC

For use with pneumatic, hydraulic, mechanical or spring applied caliper disc brakes

Weight 1.4 lbs. .64 kgs.

Disc Thickness: 0.156"

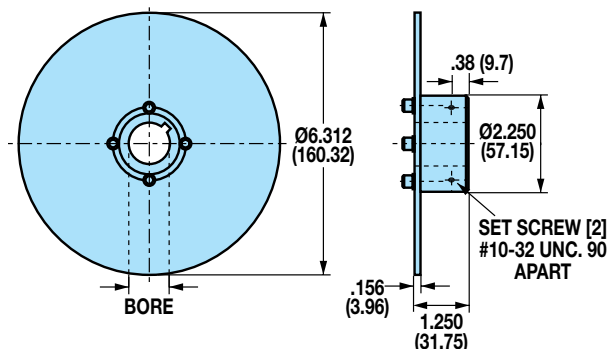

ASSY NO.	BORE	KEY SIZE
0801-0008	.500"	.125" x .125"
0801-0010	.625"	.188" x .188"
0801-0012	.750"	.188" x .188"

ASSY NO.	BORE	KEY SIZE
0801-0014	.875"	.188" x .188"
0801-0016	1.000"	.250" x .250"

### 10" DISC

For use with pneumatic, hydraulic, mechanical or spring applied caliper disc brakes

Weight 5.5 lbs. 2.49 kgs.

Disc Thickness: 0.156"

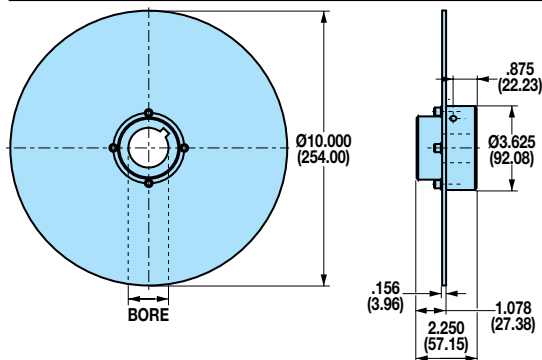

ASSY NO.	BORE	KEY SIZE
0803-0016	1.000"	.250" x .250"
0803-0018	1.125"	.250" x .250"
0803-0020	1.250"	.250" x .250"
0803-0022	1.375"	.313" x .313"

ASSY NO.	BORE	KEY SIZE
0803-0024	1.500"	.375" x .375"
0803-0026	1.625"	.375" x .375"
0803-0028	1.750"	.375" x .375"

### 8" DISC

For use with pneumatic, hydraulic, mechanical or spring applied caliper disc brakes

Weight 3.5 lbs. 1.59 kgs.

Disc Thickness: 0.156"

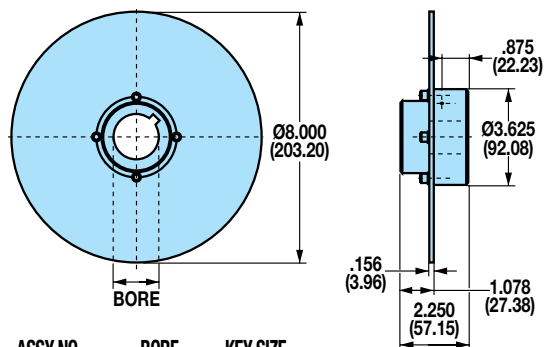

ASSY NO.	BORE	KEY SIZE
0802-0016	1.000"	.250" x .250"
0802-0018	1.125"	.250" x .250"
0802-0020	1.250"	.250" x .250"
0802-0022	1.375"	.313" x .313"

ASSY NO.	BORE	KEY SIZE
0802-0024	1.500"	.375" x .375"
0802-0026	1.625"	.375" x .375"
0802-0028	1.750"	.375" x .375"

### 12" DISC

For use with pneumatic, hydraulic, mechanical or spring applied caliper disc brakes

Weight 7.9 lbs. 3.58 kgs.

Disc Thickness: 0.156"

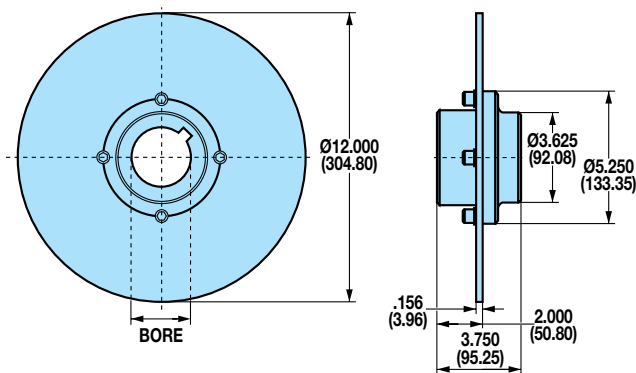

ASSY NO.	BORE	KEY SIZE
0804-0024	1.500"	.375" x .375"
0804-0028	1.750"	.375" x .375"
0804-0032	2.000"	.500" x .500"

ASSY NO.	BORE	KEY SIZE
0804-0036	2.250"	.500" x .500"
0804-0040	2.500"	.625" x .625"

### 16" DISC

For use with pneumatic, hydraulic, mechanical or spring applied caliper disc brakes

Weight 14.1 lbs. 6.40 kgs.

Disc Thickness: 0.250"

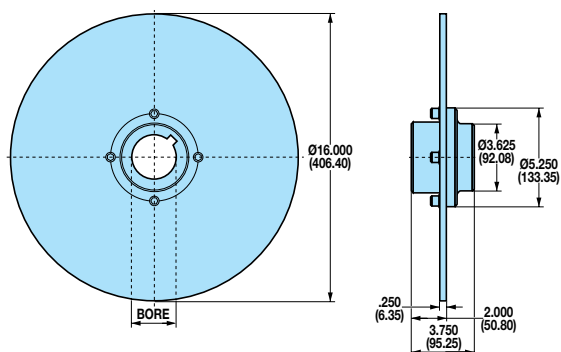

ASSY NO.	BORE	KEY SIZE
0805-0024	1.500"	.375" x .375"
0805-0028	1.750"	.375" x .375"
0805-0032	2.000"	.500" x .500"

ASSY NO.	BORE	KEY SIZE
0805-0036	2.250"	.500" x .500"
0805-0040	2.500"	.625" x .625"

## FIXED HUB & DISC ASSEMBLIES WITH QUICK DISCONNECT (Q.D.) BUSHINGS

### AVAILABLE STYLES

#### Hub & Disc Assembly with Quick Disconnect (Q.D.) Bushings



PICTURED: 0808-0114

### 6 5/16" DISC

For use with pneumatic, hydraulic, mechanical or spring applied caliper disc brakes

Weight 2.1 lbs. .95 kgs.

Disc Thickness: 0.156"

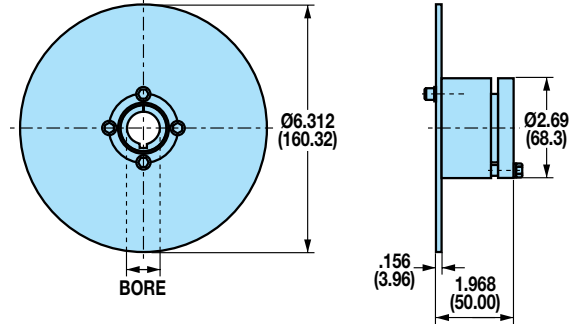

ASSY NO.	BORE	KEY SIZE
0801-0109	.563"	.125" x .125"
0801-0110	.625"	.188" x .188"
0801-0111	.688"	.188" x .188"
0801-0112	.750"	.188" x .188"

ASSY NO.	BORE	KEY SIZE
0801-0114	.875"	.188" x .188"
0801-0115	.938"	.250" x .250"
0801-0116	1.000"	.250" x .250"
0801-0117	1.063"	.250" x .250"

### FIXED HUB & DISC SPECIFICATIONS

Disc material:	Carbon 1010 steel
Disc manufacturing details:	Flat within .010 inch, stress relieved and blanchard ground to an 80 (RMS) micro-inch finish
Bushings:	Upper lock quick disconnect
Included fasteners:	Socket head cap screws Key way set screws

### 8" DISC

For use with pneumatic, hydraulic, mechanical or spring applied caliper disc brakes

Weight 2.8 lbs. 1.27 kgs.

Disc Thickness: 0.156"

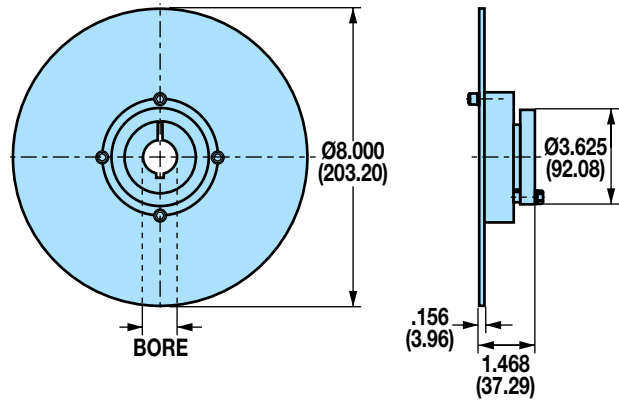

ASSY NO.	BORE	KEY SIZE
0802-0108	.500"	.125" x .125"
0802-0109	.563"	.125" x .125"
0802-0110	.625"	.188" x .188"
0802-0111	.688"	.188" x .188"
0802-0112	.750"	.188" x .188"
0802-0113	.813"	.188" x .188"
0802-0114	.875"	.188" x .188"
0802-0115	.938"	.250" x .250"
0802-0116	1.000"	.250" x .250"

ASSY NO.	BORE	KEY SIZE
0802-0117	1.063"	.250" x .250"
0802-0118	1.125"	.250" x .250"
0802-0119	1.188"	.250" x .250"
0802-0120	1.250"	.250" x .250"
0802-0121	1.313"	.313" x .313"
0802-0122	1.375"	.313" x .313"
0802-0123	1.438"	.375" x .250**
0802-0124	1.500"	.375" x .250**
0802-0125	1.563"	.375" x .250**

### PERFORMANCE DATA

#### Maximum Torque Ratings

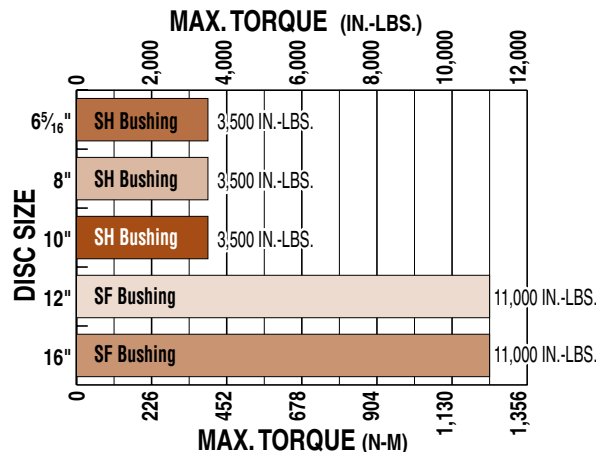

\*NON-STANDARD KEYS ARE SUPPLIED ALONG WITH HUB AND DISC ASSEMBLIES

## FIXED HUB & DISC ASSEMBLIES WITH QUICK DISCONNECT (Q.D.) BUSHINGS

### 10" DISC

For use with pneumatic, hydraulic, mechanical or spring applied caliper disc brakes

Weight 4.1 lbs. 1.86 kgs. Disc Thickness: 0.156"

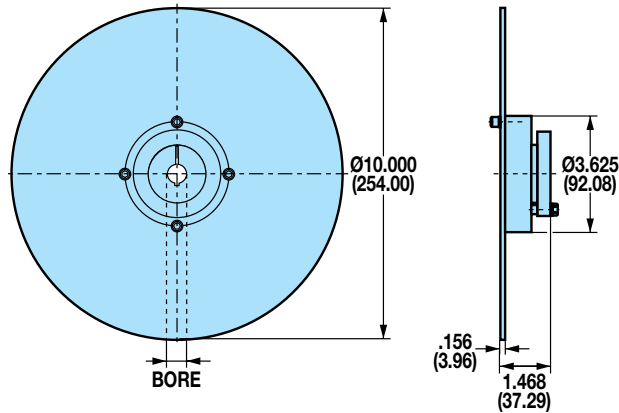

ASSY NO.	BORE	KEY SIZE
0803-0110	.625"	.188" x .188"
0803-0111	.688"	.188" x .188"
0803-0112	.750"	.188" x .188"
0803-0114	.875"	.188" x .188"
0803-0115	.938"	.250" x .250"
0803-0116	1.000"	.250" x .250"
0803-0117	1.063"	.250" x .250"
0803-0118	1.125"	.250" x .250"

ASSY NO.	BORE	KEY SIZE
0803-0119	1.188"	.250" x .250"
0803-0120	1.250"	.250" x .250"
0803-0121	1.313"	.313" x .313"
0803-0122	1.375"	.313" x .313"
0803-0123	1.438"	.375" x .250**
0803-0124	1.500"	.375" x .250**
0803-0125	1.563"	.375" x .250**

\*NON-STANDARD KEYS ARE SUPPLIED ALONG WITH HUB AND DISC ASSEMBLIES

### 12" DISC

For use with pneumatic, hydraulic, mechanical or spring applied caliper disc brakes

Weight 9.3 lbs. 4.22 kgs. Disc Thickness: 0.156"

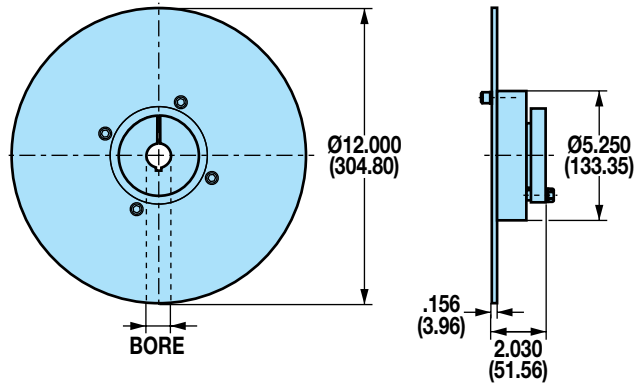

ASSY NO.	BORE	KEY SIZE
0804-0108	.500"	.125" x .125"
0804-0112	.750"	.188" x .188"
0804-0114	.875"	.188" x .188"
0804-0115	.938"	.250" x .250"
0804-0116	1.000"	.250" x .250"
0804-0117	1.063"	.250" x .250"
0804-0118	1.125"	.250" x .250"
0804-0119	1.188"	.250" x .250"
0804-0120	1.250"	.250" x .250"
0804-0121	1.313"	.313" x .313"
0804-0122	1.375"	.313" x .313"
0804-0123	1.438"	.375" x .375"
0804-0124	1.500"	.375" x .375"
0804-0125	1.563"	.375" x .375"
0804-0126	1.625"	.375" x .375"
0804-0127	1.688"	.375" x .375"

ASSY NO.	BORE	KEY SIZE
0804-0128	1.750"	.375" x .375"
0804-0130	1.875"	.500" x .500"
0804-0131	1.938"	.500" x .500"
0804-0132	2.000"	.500" x .500"
0804-0133	2.063"	.500" x .500"
0804-0134	2.125"	.500" x .500"
0804-0135	2.188"	.500" x .500"
0804-0136	2.250"	.500" x .500"
0804-0137	2.313"	.500" x .625**
0804-0138	2.375"	.500" x .625**
0804-0139	2.438"	.500" x .625**
0804-0140	2.500"	.500" x .625**
0804-0141	2.563"	.375" x .625**
0804-0142	2.625"	.375" x .625**
0804-0143	2.688"	.375" x .625**
0804-0144	2.750"	.375" x .625**

### 16" DISC

For use with pneumatic, hydraulic, mechanical or spring applied caliper disc brakes

Weight 18.1 lbs. 8.21 kgs. Disc Thickness: 0.250"

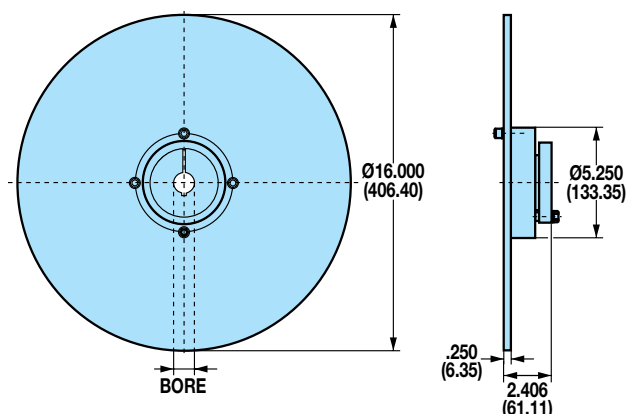

ASSY NO.	BORE	KEY SIZE
0805-0108	.500"	.125" x .125"
0805-0112	.750"	.188" x .188"
0805-0114	.875"	.188" x .188"
0805-0116	1.000"	.250" x .250"
0805-0117	1.063"	.250" x .250"
0805-0118	1.125"	.250" x .250"
0805-0119	1.188"	.250" x .250"
0805-0120	1.250"	.250" x .250"
0805-0121	1.313"	.313" x .313"
0805-0122	1.375"	.313" x .313"
0805-0123	1.438"	.375" x .375"
0805-0124	1.500"	.375" x .375"
0805-0125	1.563"	.375" x .375"
0805-0126	1.625"	.375" x .375"

ASSY NO.	BORE	KEY SIZE
0805-0128	1.750"	.375" x .375"
0805-0130	1.875"	.500" x .500"
0805-0131	1.938"	.500" x .500"
0805-0132	2.000"	.500" x .500"
0805-0134	2.125"	.500" x .500"
0805-0135	2.188"	.500" x .500"
0805-0137	2.313"	.500" x .625**
0805-0138	2.375"	.500" x .625**
0805-0139	2.438"	.500" x .625**
0805-0140	2.500"	.500" x .625**
0805-0141	2.563"	.375" x .625**
0805-0143	2.688"	.375" x .625**
0805-0144	2.750"	.375" x .625**

CALIPER  
DISC  
BRAKES

FEATURES

APPLICATIONS

SELECTION  
GRAPHS

PNEUMATIC  
BRAKES

P10

P20

P220

HYDRAULIC  
BRAKES

H10

H20

H220

H220I

H441

H960

HYDRAULIC/  
MECHANICAL  
BRAKE  
COMBOS

H/ME20

H/ME220

MECHANICAL  
BRAKES

ME10

ME20

ME220

MB3

SPRING  
APPLIED  
BRAKES

FS20

FS220

FS220I

FS595

DISCS  
HUBS &  
BUSHINGS

TENSION  
CONTROL  
COMBINATIONS

INTENSIFIER

SELECTION

WORKSHEET

## QUICK DISCONNECT (Q.D.) BUSHINGS & HUBS

### AVAILABLE STYLES

**Quick Disconnect (Q.D.) Bushings must be used with Quick Disconnect (Q.D.) Hubs**



PICTURED: 0801-1151



PICTURED: 0801-1119

### Q.D. BUSHING - 6<sup>5</sup>/<sub>16</sub>" DISC (SH)

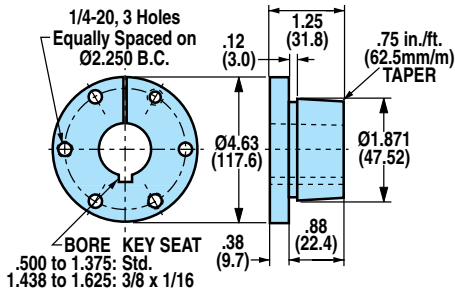

ASSY. NO.	TYPE	BORE	KEY SIZE	WT. (LBS.)	WT. (KGS.)
0801-1123	SH	.563"	.125" x .125"	0.9	.41
0801-1125	SH	.688"	.188" x .188"	0.8	.36
0801-1126	SH	.750"	.188" x .188"	0.8	.36
0801-1127	SH	.813"	.188" x .188"	0.8	.36
0801-1128	SH	.875"	.188" x .188"	0.8	.36
0801-1129	SH	.938"	.250" x .250"	0.8	.36
0801-1131	SH	1.000"	.250" x .250"	0.7	.32
0801-1132	SH	1.063"	.250" x .250"	0.7	.32
0801-1133	SH	1.125"	.250" x .250"	0.7	.32

### Q.D. BUSHING - 8" & 10" DISC (SH)

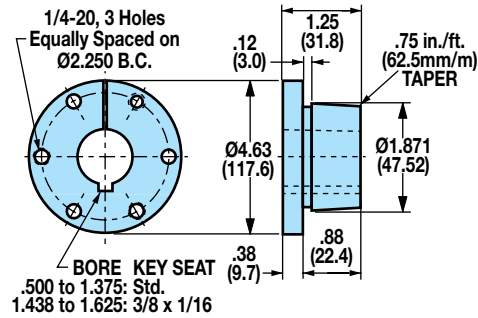

ASSY. NO.	TYPE	BORE	KEY SIZE	WT. (LBS.)	WT. (KGS.)
0801-1122	SH	.500"	.125" x .125"	0.9	.41
0801-1123	SH	.563"	.125" x .125"	0.9	.41
0801-1124	SH	.625"	.188" x .188"	0.9	.41
0801-1125	SH	.688"	.188" x .188"	0.8	.36
0801-1126	SH	.750"	.188" x .188"	0.8	.36
0801-1127	SH	.813"	.188" x .188"	0.8	.36
0801-1128	SH	.875"	.188" x .188"	0.8	.36
0801-1129	SH	.938"	.250" x .250"	0.8	.36
0801-1131	SH	1.000"	.250" x .250"	0.7	.32
0801-1132	SH	1.063"	.250" x .250"	0.7	.32
0801-1133	SH	1.125"	.250" x .250"	0.7	.32
0801-1134	SH	1.188"	.250" x .250"	0.6	.27
0801-1135	SH	1.250"	.250" x .250"	0.6	.27
0801-1136	SH	1.313"	.313" x .313"	0.5	.23
0801-1137	SH	1.375"	.313" x .313"	0.5	.23
0801-1138	SH	1.438"	.375" x .250**	0.5	.23
0801-1139	SH	1.500"	.375" x .250**	0.4	.18
0801-1140	SH	1.563"	.375" x .250**	0.4	.18
0801-1141	SH	1.625"	.375" x .250**	0.4	.18

\*NON-STANDARD KEYS ARE SUPPLIED ALONG WITH HUB AND DISC ASSEMBLIES

### Q.D. HUB - 8" & 10" DISC (SH)

For use with quick disconnect (Q.D.) bushing

0802-1137 Weight 1.6 lbs. .73 kgs.

### Q.D. HUB - 6<sup>5</sup>/<sub>16</sub>" DISC (SH)

For use with quick disconnect (Q.D.) bushing

0801-1119 Weight 1.2 lbs. .54 kgs.

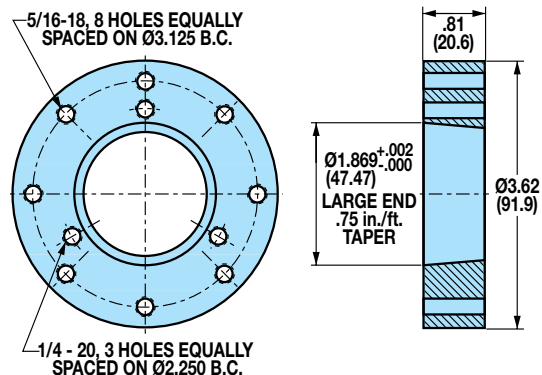
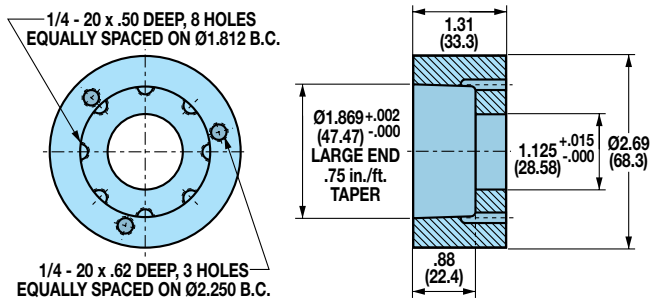

## QUICK DISCONNECT (Q.D.) BUSHINGS & HUBS

### Q.D. BUSHING INSTALLATION

When a wrench or length of pipe is used to increase leverage in tightening bushing screws, it is imperative to adhere to the wrench torque values given below.

When mounting the bushing, the tightening force on the screws is multiplied many times by the wedging action of the tapered surface. This action compresses the bushing for a snug fit on the shaft. The bushing screws should always be tightened alternately and progressively.

BUSHING	WRENCH TORQUE (IN.-LBS.)	WRENCH LENGTH (INCHES)	WRENCH PULL (POUNDS)
SH	108	4	27
SF	360	6	60

### Q.D. BUSHING - 12" & 16" DISC (SF)

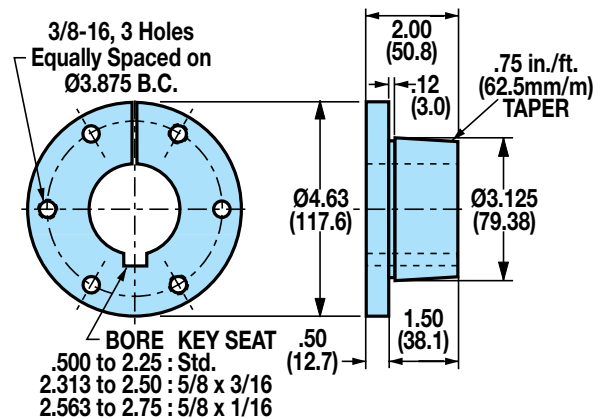

ASSY. NO.	TYPE	BORE	KEY SIZE	WT. (LBS.)	WT. (KGS.)
0801-1142	SF	.500"	.125" x .125"	4.9	2.22
0801-1143	SF	.563"	.125" x .125"	4.9	2.22
0801-1144	SF	.625"	.188" x .188"	4.8	2.18
0801-1145	SF	.688"	.188" x .188"	4.8	2.18
0801-1146	SF	.750"	.188" x .188"	4.8	2.18
0801-1147	SF	.813"	.188" x .188"	4.7	2.13
0801-1148	SF	.875"	.188" x .188"	4.7	2.13
0801-1149	SF	.938"	.250" x .250"	4.6	2.09
0801-1150	SF	1.000"	.250" x .250"	4.6	2.09
0801-1151	SF	1.063"	.250" x .250"	4.5	2.04
0801-1152	SF	1.125"	.250" x .250"	4.5	2.04
0801-1153	SF	1.188"	.250" x .250"	4.4	2.00
0801-1154	SF	1.250"	.250" x .250"	4.4	2.00
0801-1155	SF	1.313"	.313" x .313"	4.3	1.95
0801-1156	SF	1.375"	.313" x .313"	4.2	1.91
0801-1157	SF	1.438"	.375" x .375"	4.1	1.86
0801-1158	SF	1.500"	.375" x .375"	4.0	1.81
0801-1159	SF	1.563"	.375" x .375"	4.0	1.81
0801-1160	SF	1.625"	.375" x .375"	3.9	1.77
0801-1161	SF	1.688"	.375" x .375"	3.8	1.72
0801-1162	SF	1.750"	.375" x .375"	3.7	1.68
0801-1163	SF	1.875"	.500" x .500"	3.5	1.59
0801-1164	SF	1.938"	.500" x .500"	3.4	1.54
0801-1165	SF	2.000"	.500" x .500"	3.3	1.50
0801-1166	SF	2.063"	.500" x .500"	3.2	1.45
0801-1167	SF	2.125"	.500" x .500"	3.1	1.41
0801-1168	SF	2.188"	.500" x .500"	3.0	1.36
0801-1169	SF	2.250"	.500" x .500"	2.9	1.32
0801-1170	SF	2.313"	.500" x .625**	2.9	1.32
0801-1171	SF	2.375"	.500" x .625**	2.8	1.27
0801-1172	SF	2.438"	.500" x .625**	2.7	1.22
0801-1173	SF	2.500"	.500" x .625**	2.6	1.18
0801-1174	SF	2.563"	.375" x .625**	2.4	1.09
0801-1175	SF	2.625"	.375" x .625**	2.3	1.04
0801-1176	SF	2.688"	.375" x .625**	2.2	1.00
0801-1177	SF	2.750"	.375" x .625**	2.0	.91
0801-1178	SF	2.812"	NONE	1.8	.82
0801-1179	SF	2.937"	NONE	1.5	.68

### Q.D. HUB - 12" & 16" DISC (SF)

For use with quick disconnect (Q.D.) bushing

0804-1141 Weight 4.70 lbs. 2.13 kgs.

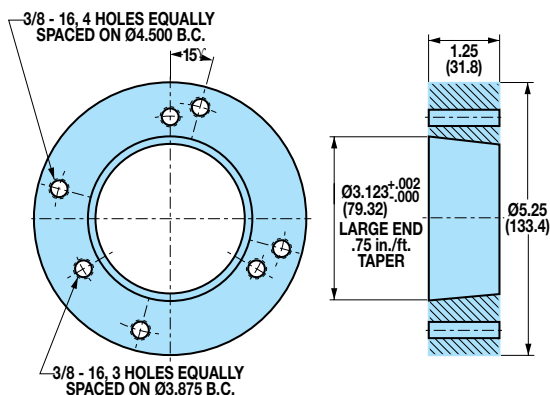

\*NON-STANDARD KEYS ARE SUPPLIED ALONG WITH HUB AND DISC ASSEMBLIES



## ONE-PIECE HUB AND DISC

### AVAILABLE STYLES

#### One-Piece Hub and Disc



PICTURED: 0801-1210

### ONE-PIECE HUB & DISC SPECIFICATIONS

Disc material:	Grey cast iron (G3000)
Disc manufacturing details:	Flat within .010 inch, 80 (RMS) micro-inch finish
Included fasteners:	none

### 6" DISC

For use with pneumatic, hydraulic, mechanical or spring applied caliper disc brakes

Weight 1.8 lbs. .82 kgs. Disc Thickness: 0.187"

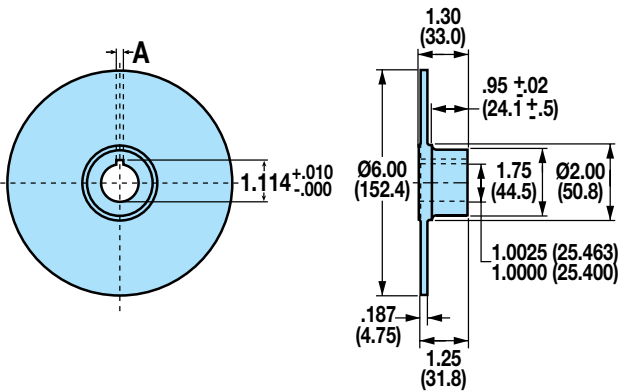

ASSY. NO.	BORE	KEY SIZE	DIM "A"
0801-1210	1.000"	.188" x .188"	.190" / .188"
0801-1211	1.000"	.25" x .125"	.253" / .251"

## BLANK DISC

### AVAILABLE STYLES

#### Blank Disc



PICTURED: 0801-1200

### BLANK DISC SPECIFICATIONS

Disc material:	SAE 1010-1020 CRS
Disc manufacturing details:	Flat within .010 inch, 80 (RMS) micro-inch finish
Included fasteners:	none

### 6<sup>5</sup>/<sub>16</sub>", 8", 10", 12" & 16" DISCS

For use with pneumatic, hydraulic, mechanical or spring applied caliper disc brakes

#### NO DIMENSIONAL DRAWING REQUIRED

ASSY. NO.	DISC DIAMETER	DISC THICKNESS	WT. (LBS.)	WT. (KGS.)
0801-1200	6.313"	.156"	1.3	.59
0802-1200	8.000"	.156"	2.2	1.00
0803-1200	10.000"	.156"	3.4	1.54
0804-1200	12.000"	.156"	4.8	2.18
0805-1200	16.000"	.250"	13.7	6.21

- FEATURES
- APPLICATIONS
- SELECTION GRAPHS
- PNEUMATIC BRAKES
- P10
- P20
- P220
- HYDRAULIC BRAKES
- H10
- H20
- H220
- H2201
- H441
- H960
- HYDRAULIC/MECHANICAL BRAKE COMBOS
- H/ME20
- H/ME220
- MECHANICAL BRAKES
- ME10
- ME20
- ME220
- ME3
- SPRING APPLIED BRAKES
- FS20
- FS220
- FS2201
- FS395
- DISCS HUBS & BUSHINGS
- TENSION CONTROL COMBINATIONS
- INTENSIFIER
- SELECTION WORKSHEET

## DISC WITH BOLT CIRCLES & PILOT HOLE

### AVAILABLE STYLES

Disc with Bolt Circles & Pilot Hole



PICTURED: 0801-1208

### DISC SPECIFICATIONS

Disc material:	SAE 1010-1020 CRS
Disc manufacturing details:	Flat within .010 inch, 80 (RMS) micro-inch finish
Included fasteners:	none

### 6<sup>5</sup>/<sub>16</sub>" , 8" , 10" , 12" & 16" DISCS

For use with pneumatic, hydraulic, mechanical or spring applied caliper disc brakes

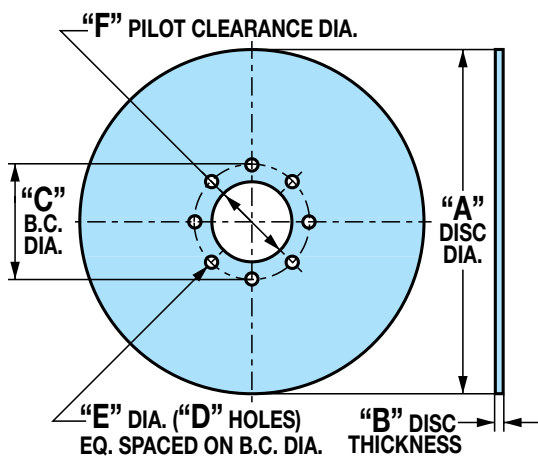

ASSEMBLY NUMBER	"A" DISC DIA.	"B" DISC THK	"C" B.C. DIA.	"D" NO. OF BOLT HOLES	"E" HOLE DIA.	"F" PILOT CLEAR. DIA.
0801-1206	6.313"	.156"	1.812"	8	.332"	1.376"
0802-1208	8.000"	.156"	3.125"	8	.343"	2.375"
0803-1210	10.000"	.156"	3.125"	8	.343"	2.375"
0804-1212	12.000"	.156"	4.500"	4	.406"	3.750"
0805-1216	16.000"	.250"	4.500"	4	.406"	3.750"
0805-1220	16.000"	.500"	4.500"	4	.406"	3.750"

## INTENSIFIER

### AVAILABLE STYLES

Intensifier



PICTURED: 1770-0000

**NOTE: NOT FOR USE WITH SPRING APPLIED OR SPRING RETRACTING CALIPER DISC BRAKES**

### INTENSIFIER SPECIFICATIONS

INPUT:	Pneumatic pressure, maximum:	100 PSI
	Piston seal:	U-cup design
	Cylinder material:	Hard coated aluminum
	Input to output ratio:	1 : 10
OUTPUT:	Hydraulic pressure, maximum:	1,000 PSI
	Hydraulic fluid displacement:	0.44 in <sup>3</sup>
	Cylinder seal:	O-ring, Buna-N
	Cylinder material:	Aluminum
	1/8 NPT Port:	Standard, for oil reservoir and/or pressure gauge

### Options:

Hydraulic cylinder seal:	O-ring, EPR
Hydraulic cylinder seal:	O-ring, Viton®

### INTENSIFIER KIT

For use with non-spring retracting hydraulic caliper disc brakes, Tolomatic series: H10, H20, H/ME20, H220, H/ME220

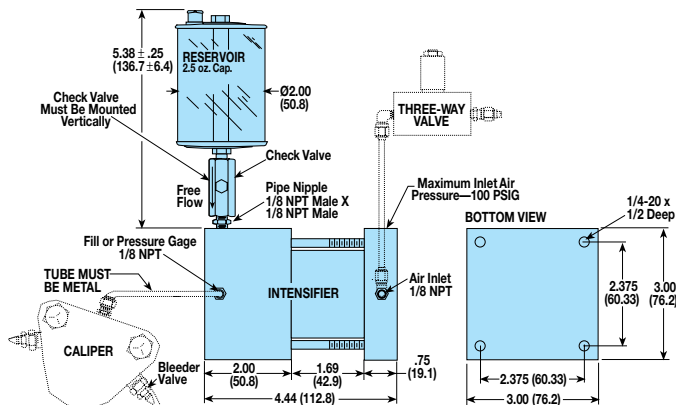

ASSEMBLY NUMBER	SEAL TYPE	KIT INCLUDES:	INTENSIFIER NUMBER
1770-0002	Buna-N	Intensifier, reservoir, check valve & pipe nipple	1770-0000
1770-0003	EPR	Intensifier, reservoir, check valve & pipe nipple	1770-0001
1770-0004	Viton®	Intensifier, reservoir, check valve & pipe nipple	1770-0005



## TENSION CONTROL COMBINATIONS

### AVAILABLE STYLES

#### Ventilated Disc

FIXED MOUNT - FIXED DISC



PICTURED: 0803-1214

### DISC PERFORMANCE DATA

#### Thermal Dissipative Capacity of Ventilated Disc

(BASED ON A MAXIMUM DISC TEMPERATURE OF 375°F AND AN AMBIENT TEMPERATURE OF 75°F)

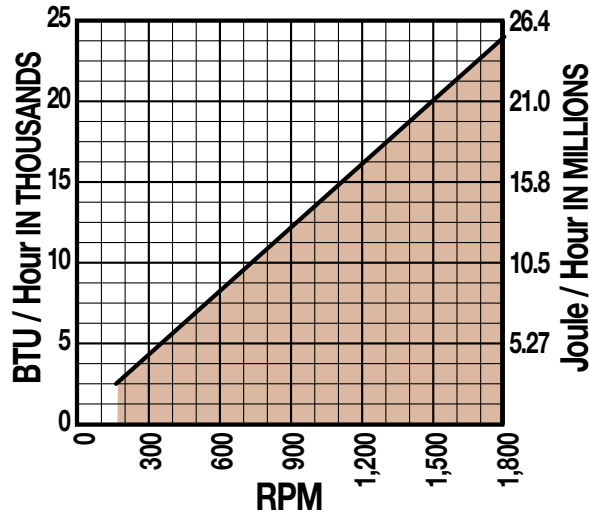

### 11" DISC

For use with hydraulic caliper disc brakes

Weight 15.4 lbs. 6.99 kgs. Disc Thickness: 1.20"

SEE CALIPER & DISC DRAWING AT RIGHT FOR DISC DIMENSIONS

ASSY. NO.	DESCRIPTION	COMPONENTS INCLUDED
0803-0202	Ventilated Disc Assembly	Ventilated Disc, Pilot Plate HHCS (1/2"-13 x 1-1/2") [5], Lockwashers [5]

### PERFORMANCE DATA

PERFORMANCE DATA GRAPHS ARE REPEATED FROM: PAGE 36 - PNEUMATIC  
PAGE 42 - HYDRAULIC

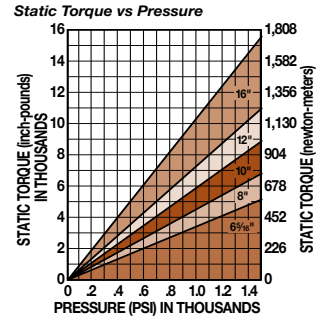
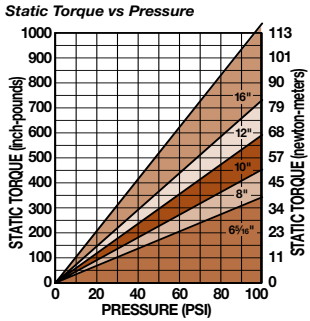
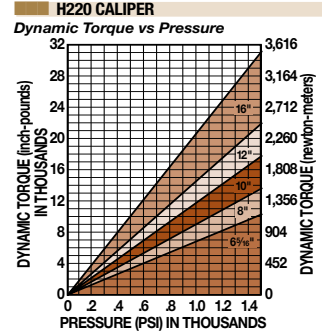
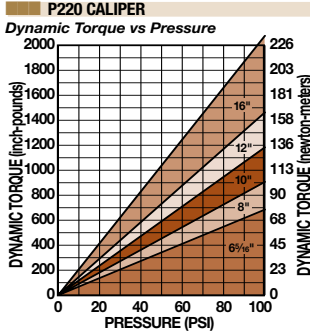

### CALIPER & DISC

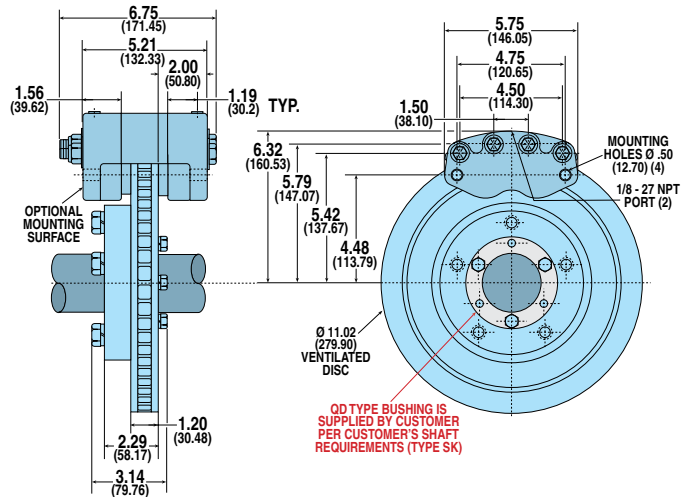

### Calipers for Ventilated Disc

ASSY. NO.	MODEL CODE	DESCRIPTION
0735-0304	P220DX	Pneumatic, Double Acting
0735-0704	P220DX	Pneumatic, Double Acting w/Segmented Pucks
0735-0312	H220DXC	Hydraulic, Double Acting w/Bleeder Fittings

### DISC SIZING EQUATIONS

DYNAMIC TORQUE (IN.-LBS.) = 2.88 x BRAKING RADIUS (IN.) x PRESSURE (PSI)  
 STATIC (PARKING) TORQUE (IN.-LBS.) = 1.44 x BRAKING RADIUS (IN.) x PRESSURE (PSI)

### BRAKE MODEL LETTER CODES

C w/ bleeder fittings	H Hydraulic	X Non-standard Disc Thickness
D Dual Acting	P Pneumatic	

- FEATURES
- APPLICATIONS
- SELECTION GRAPHS
- PNEUMATIC BRAKES
- P10
- P20
- P220
- HYDRAULIC BRAKES
- H10
- H20
- H220
- H2201
- H441
- H960
- HYDRAULIC/MECHANICAL BRAKE COMBOS
- H/ME20
- H/ME220
- MECHANICAL BRAKES
- ME10
- ME20
- ME220
- MB3
- SPRING APPLIED BRAKES
- FS20
- FS220
- FS2201
- FS395
- DISCS HUBS & BUSHINGS
- TENSION CONTROL COMBINATIONS
- INTENSIFIER
- SELECTION WORKSHEET

## SELECTION: GENERAL

### HOW CALIPER DISC BRAKES WORK

Basically, a caliper disc brake functions like an ordinary rod cylinder. Components consist of a piston, a puck (or pad) of wearable friction material, a housing, and opposing side and a disc on which the brake acts. When pressure is applied to the piston, the puck is

moved into contact with the disc, causing the disc to stop rotating or, in a tensioning application, to supply constant drag. The housing contains the piston and

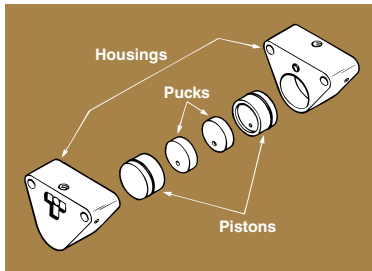

puck and is located above the disc. There are always two sides to a caliper disc brake: One is known as the “live side” with the piston and puck; the other may be either another “live side” or it may be a “dead side” (another puck which contacts the disc when the “live side” piston is actuated).

Disc brakes are widely used in three areas: Stopping, retarding (tensioning) and holding. In any application it is necessary to determine how much torque is required, how much heat will be generated (and thus, to be dissipated) and the anticipated service life of the linings. Once these variables are determined, then find the combination of disc and caliper that will most economically meet these requirements.

### DETERMINE THE KIND OF BRAKING TO BE DONE

- Industrial
  - Tensioning
  - Constant Slip
- Vehicular

### DETERMINE PRESSURE (LEVER FORCE) AVAILABLE

All torque calculations (except for spring applied brakes) are based on the pressure (lever force) available for your application. Maximum pneumatic pressure for Tolomatic caliper disc brakes is 100 PSI. Maximum hydraulic pressure varies by model between 1,000 PSI and 2,000 PSI. Maximum lever force for mechanical brakes varies with model and lever length. Refer to individual models for pressure (lever force) ratings.

### CALCULATE THE TORQUE REQUIRED

For convenience, we express the torque formulae separately for industrial applications, vehicular applications and tensioning applications. See the formulae section

(pages 92-95) to determine the torque needed for your application.

### CALCULATE HEAT DISSIPATION REQUIRED

The energy generated will either be expressed as BTU per hour (particularly for tensioning applications) or BTU per stop. The formulae for calculating these values are different for industrial, tensioning and vehicular braking. See the formulae section (pages 92-95) to determine the heat generated for your application.

### DETERMINE MAXIMUM DISC DIAMETER

There are two criteria to determine disc diameter:

- **ENVELOPE SIZE** – how much room is allowed in the design for disc and caliper. This affects the braking radius and thus the torque that the caliper can develop.
- **HEAT DISSIPATION REQUIRED** – Cycle rate and torque are needed to determine the heat an application will generate per hour, and thus the heat that the disc will need to dissipate. Discs will normally dissipate heat at the rate of 3 BTU per hour, per square inch of disc area. This assumes a disc temperature of 220° F above ambient temperature of 80°F. Discs rotating at extreme speeds may dissipate heat at rates as high as 5 BTU per hour, per square inch of disc area. If required torque, cycle rate and small envelope size combine to create heat dissipation requirements that are greater than standard disc capabilities, your choices are:
  - 1.) Use a thicker disc (that will act as a heat sink).
  - 2.) Use multiple discs/calipers for the application.
  - 3.) Use a ventilated disc (to increase the heat dissipation rate).
  - 4.) Cool disc with forced air (to increase the heat dissipation rate).

### DETERMINE THE TYPE OF BRAKE ACTUATION

Choose a brake based on the type of actuation available (pneumatic, hydraulic, etc.) and whether dynamic or static braking is required for the application.

Tolomatic offers brakes actuated in 5 different ways:

#### • PNEUMATIC

Pneumatic actuation is used in industrial and tensioning applications because pneumatic service is easily controllable and readily available in most industrial settings.

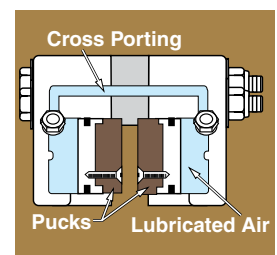



## SELECTION: GENERAL

### • HYDRAULIC

Hydraulic actuated brakes are normally used in applications where higher torque output is needed. They may be operated with a variety of fluids including the standard mineral based hydraulic oils, automotive brake fluids and non-flammable phosphate ester fluids (each requires different seals).

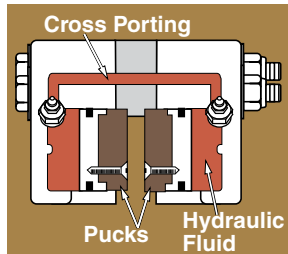

### • MECHANICAL

Mechanically actuated brakes are often used for emergency stopping or holding brakes or in situations where pneumatic or hydraulic pressure is not available. Mechanical caliper disc brakes operate when the cam lever is rotated. This pushes the actuating pins against the lining's backing plate thus forcing the lining into the disc.

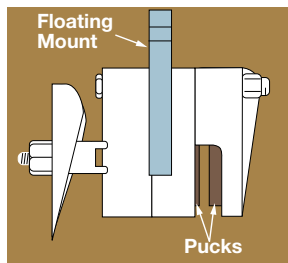

### • HYDRAULIC / MECHANICAL COMBOS

Combination brakes give the added flexibility to apply mechanical braking as well as hydraulic braking from one caliper.

### • SPRING APPLIED

These brakes require pressure (normally hydraulic) to release it from the disc. Braking force is provided by a stack (or stacks) of Belleville spring washers. The conical washers are capable of storing enormous force. When the brake is pressurized the force moves a piston(s) to compress the spring washer stack(s), thus releasing the disc. Because the force applied by the spring stack is reduced as the spring washers expand, spring applied brakes are used mainly for applications that require occasional stopping or holding. They should not be used in tension-constant slip applications or cyclic stopping industrial applications.

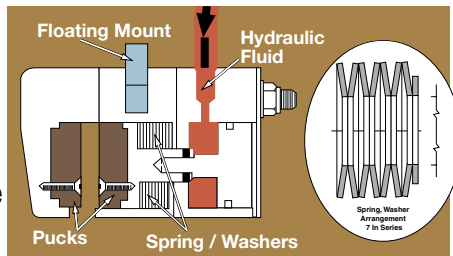

### CHOOSE TOLOMATIC BRAKE SIZE

Tolomatic brakes are grouped by size. These sizes relate to the piston size for each brake. Because maximum pressure (lever force) generated differs between the type of brake (pneumatic, hydraulic, etc.), the maximum torque available differs. The graphs on pages 29 to 31 will be helpful in determining the approximate brake size that will work for your application. Go to each individual brake section to find the equations and performance graphs for that brake.

For easy reference, torque output equations that apply to each series of brake are shown at the bottom of the page (see example below). Each equation features:

- [1.] a constant value (*A product of brake piston area, the coefficient of friction and a safety factor.*), multiplied by
- [2.] braking radius (*Common disc sizes appear on the page with the dimensional drawing.*), multiplied by
- [3.] pressure (lever force) (*You will need to determine.*).

DISC SIZING EQUATIONS		
1	2	3
$\text{STATIC (PARKING) TORQUE (IN.-LBS.)} = 6.99 \times \text{BRAKING RADIUS (IN.)} \times \text{LEVER FORCE (LBS.)}$		
$\text{BRAKING RADIUS (IN.)} = \text{DISC DIAMETER} \div 2 - 0.688$		

The performance data graphs represent these equations for common disc sizes in a convenient, visual way to quickly see how well each brake size will fit your application.

### CHOOSE DOUBLE ACTING OR SINGLE ACTING BRAKE

#### Double Acting

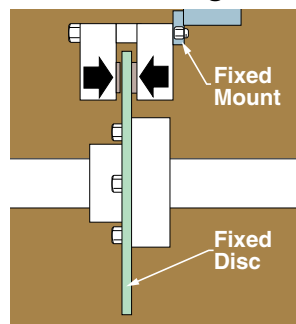

#### Single Acting

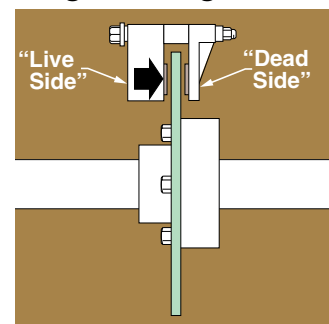

- Double acting brakes feature two "live sides". Each side has a piston that actuates the lining, forcing it against the disc. Hydraulic and pneumatic brakes are available in double acting as well as single acting models.
- Single acting brakes have a piston that actuates the lining on the "live side", forcing it against the disc. The "dead side" has a stationary lining attached to the housing. Since only one side has a moving piston, the brakes mounting must allow it to float. Spring applied, mechanical and hydraulic/mechanical brakes are generally single acting.



## SELECTION: GENERAL

### DETERMINE MOUNT FOR BRAKE AND DISC

#### • For Double Acting Brakes

**FIXED CALIPER MOUNT/ FIXED DISC** – A double acting caliper can be fixed mounted since both linings have pistons to move them. The disc is also fixed mounted.

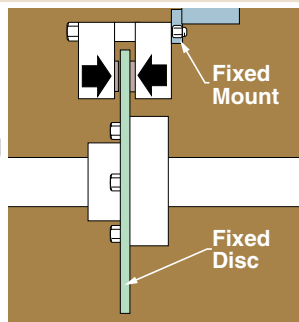

#### • For Single Acting Brakes

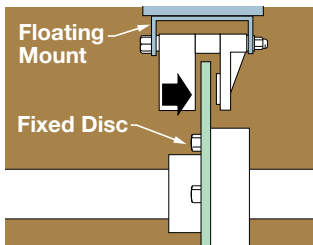

**FLOATING CALIPER MOUNT/FIXED DISC** – A floating mount bracket permits the caliper to shift position when braking force is applied. The disc is rigidly mounted to the shaft.

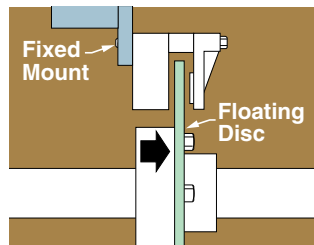

**FIXED CALIPER MOUNT/ FLOATING DISC** – The caliper is rigidly mounted and a floating disc mount attaches the disc to the shaft. The two forms of floating disc are:  
**1.)** Disc and hub are mounted on a spline on the shaft. **2.)** Hub is rigidly keyed to the shaft and the disc is spring loaded to the hub, providing floating ability.

### CONSIDER OPTIONS

Hydraulic brakes may operate with a variety of fluids. Tolomatic brakes use Buna-N seals most commonly. These seals are suited for use with standard mineral based hydraulic oil. EPR seals, for use with automotive brake fluids, are available for most Tolomatic brakes. Some models also give you the choice of Viton® seals, these seals are suited for use with nonflammable phosphate ester fluids.

Some Tolomatic brakes are available with retractable pistons. A brake with this feature has a small compression spring within the piston which causes it to retract from the

disc when pressure is released. Retractable brakes are used in applications that require a brake with absolutely no residual drag from the linings on the disc.

Almost all Tolomatic brakes can be modified to fit a variety of disc thicknesses.

**NOTE: TOLOMATIC RETRACTABLE BRAKES SHOULD NOT BE USED IN VEHICULAR APPLICATIONS WITH A MASTER CYLINDER OR WITH AN INTENSIFIER.**

### DETERMINE LIFE EXPECTANCY OF LININGS

Another consideration in selecting a brake is the life expectancy of the linings. This factor is particularly important if the brake is to be placed in a “hard-to-service” location, faces long intervals between servicing, or is to be used in a tensioning-constant slip application.

Basically, lining life expectancy is a factor of the amount of energy transmitted through the lining and may be measured in total number of stops or hours of life. Both measurements may be reduced to horsepower hours of heat that the lining must endure.

Tolomatic’s standard lining is made of a non-asbestos organic material and has a maximum operating temperature of 300°F. An optional sintered metallic lining (depending on model) offers maximum operating temperatures from 400° to 500°F. See the formulae section to determine the lining life expectancy for your application.

## SELECTION: FORMULAE: INDUSTRIAL

### INDUSTRIAL APPLICATIONS FORMULAE

#### Calculation of Torque Required

Many industrial applications are concerned with rotary motions that must be brought to rest in a specified time. The torque necessary to satisfy the time requirement must be determined. A convenient formula used to calculate the torque requirement of a single shaft system is:

$$T = \frac{WK^2N}{308t} \quad [1a]$$

Where: **T** = Torque; ft-lbs

**W** = Weight of rotating member; lbs.

**K** = Radius of gyration of rotating member; ft.

**N** = Speed of rotating shaft; rpm

**t** = Stopping time required; seconds

or: 
$$T = \frac{WK^2N}{3,696t} \quad [1b]$$

Where: **T** = Torque; in-lbs

**K** = Radius of gyration of rotating member; in.

Industrial applications often consist of more than one rotating mass system (i.e., two or more shafts with gears, sheaves, drums, etc.) interconnected and operating at different speeds. In such systems the rotating elements must be reduced to a common base. Since the energy of a rotating mass system is a function of the square of its speed, an equivalent  $WK^2$  of each rotating member relative to the shaft on which the brake disc is mounted can be calculated using the formulae in the Radius of Gyration Section (page 93).

#### Calculation of Heat Generation and Required Dissipation (Industrial)

Heat is always developed in the disc and linings of a brake when a rotating or moving body comes to rest. The kinetic energy in BTUs per stop may be expressed in the following formulae:

$$\text{BTU/Stop} = \frac{WK^2N^2}{4,570,000} \quad \text{for a single shaft system} \quad [4]$$

$$\text{BTU/Stop} = \frac{WK_e^2N_s^2}{4,570,000} \quad \text{for a multiple shaft system} \quad [5]$$

or

$$\text{BTU/Stop} = \frac{\pi TN_s t}{46,680} \quad [6]$$

Where: **T** = Torque; ft-lbs

**K** = Radius of gyration of rotating member; ft.

The weight and specific heat of the lining material is very small compared to the disc and can be ignored.

Since the amount of heat dissipated per hour by the disc at a given temperature above ambient is considered as being directly proportional to the exposed area of the disc, disc thickness should be kept small. Standard thicknesses are 5/32" and 1/4".

For the best service life the disc temperature should not exceed 300°F. Higher disc temperatures can be allowed, however, there will be a reduction in the life of the friction material. See Figure 1 (page 94).

In many applications there are no restrictions to disc diameter (within reason). Convert your calculated BTU/Stop to BTU/hr. with the following formula:

$$\text{BTU/hr.} = (\text{BTU/stop})(\text{stops/hr.}) \quad [7]$$

Then solve for the number of square feet of exposed disc area to dissipate the heat generated:

$$\text{Sq. Ft. Disc Area} = \frac{\text{BTU/hr}}{660} \quad [8]$$

Refer to Table 1 (page 94) for selection of proper disc diameter.

**NOTE: THE ABOVE FORMULA [8] IS BASED ON A 220°F TEMPERATURE RISE AND AN 80°F AMBIENT TEMPERATURE. IF A HIGHER DISC TEMPERATURE IS DESIRED REFER TO FORMULAE [14], [15], [16] IN THE TENSIONING-CONSTANT SLIP SECTION.**

If there is a restriction in the disc diameter(s) and there is sufficient time between stops or multiple of stops for heat dissipation then we can size the disc to act as a heat sink.

$$Wd = \frac{\text{BTU/hr.}}{(220)(Sp)} \quad [9]$$

Where: **Wd** = Weight of disc; lbs.

**Sp** = Specific heat of disc may be taken as .12 for steel; BTU/lbs.-°F

Refer to Table 1 (page 94) for selection. If your requirement falls outside of the standard(s) you may calculate the required thickness based on the maximum allowable diameter:

$$\text{Disc Thickness} = \frac{Wd}{(A)(.28)} \quad [10]$$

Where: **Thickness** is in inches

**A** = Area of maximum allowable diameter; in<sup>2</sup>

If it is found the disc thickness is unrealistic from an economic or space limitation standpoint, multiple discs will have to be provided or forced ventilation must be considered.

## SELECTION: FORMULAE: RADIUS OF GYRATION, TENSIONING

### RADIUS OF GYRATION FORMULAE

#### Radius of Gyration for Geometric Forms

Radius of gyration is the distance from the center of rotation at which the entire rotating mass could be concentrated and still be equivalent to the actual distributed mass.

Solid Cylinder About its Own Axis

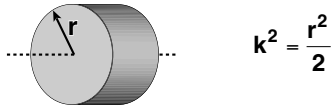

Hollow Cylinder About its Own Axis

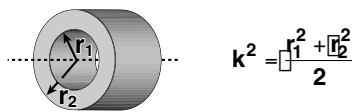

Where: **K** = Radius of gyration of rotating member; ft.  
**R** = Radius of rotating member; ft.

$$WK_e^2 = WK_s^2 + WK_1^2 \left[ \frac{N_1}{N_s} \right]^2 + \dots \quad [2]$$

Where: **WK<sub>e</sub><sup>2</sup>** = Equivalent WK<sup>2</sup> of the multiple shaft system; lbs-ft<sup>2</sup>

**WK<sub>s</sub><sup>2</sup>** = WK<sup>2</sup> of the shaft assembly on which the brake disc is mounted; lbs-ft<sup>2</sup>

**WK<sub>1</sub><sup>2</sup>** = WK<sup>2</sup> of the second shaft assembly; lbs-ft<sup>2</sup>

**N<sub>s</sub>** = speed of the shaft on which the brake disc is mounted; rpm

**N<sub>1</sub>** = speed of the second shaft; rpm

The formula for the torque required to bring the multiple shaft system to rest then becomes:

$$T = \frac{WK_e^2 N_s}{308t} \quad [3a]$$

Where: **T** = Torque; ft-lbs

$$\text{or } T = \frac{WK_e^2 N_s}{3,696t} \quad [3b]$$

Where: **T** = Torque; in-lbs (**WK<sub>e</sub><sup>2</sup>** is in lbs-in<sup>2</sup>)

### TENSIONING / CONSTANT SLIP APPLICATIONS FORMULAE

#### Calculation of Torque Required

Applications involving tensioning or constant drag require a different set of formulae since there is not a finite time to stop. Tensioning devices are designed to operate over an infinite period of time. The basic formula for calculating torque for web tensioning is:

$$T = (L)(F)(R) \quad [11]$$

Where: **T** = Torque; in-lbs

**L** = web width, in.

**F** = tension; lbs./inch of web width

**R** = maximum roll radius; in.

The basic formula for calculating BTUs generated per hour is:

$$\text{BTU/hr.} = \frac{(T)(\text{rpm})}{24.75} \quad [12]$$

#### Calculation of Heat Generation and Required Dissipation (Tensioning)

In tensioning applications the amount of heat generated must be dissipated as well. Often web velocity is given in fpm, this can be converted to rpm by:

$$\text{rpm} = \frac{\text{fpm}}{C} \quad [13]$$

Where: **C** = Circumference of roll at maximum diameter; ft.

Therefore to solve for the sq. ft. of surface area of the disc(s):

$$\text{Sq. Ft. Disc Area} = \frac{\text{BTU/hr}}{660} \quad [14]$$

The constant of 660 is based on a maximum disc temperature of 300°F.

To develop a constant for higher disc temperature:

$$\text{Constant} = (3)(\text{temperature rise above ambient}) \quad [15]$$

The actual disc temperature becomes:

$$\text{Disc Temperature} = \text{Temperature Rise} + \text{Ambient, } ^\circ\text{F} \quad [16]$$

Refer to Table 1. Select disc or discs equal to (or greater than) calculated sq. ft. Remember the higher the disc temperature the lower the life of the friction material. See Figure 1 (page 94).

## SELECTION: LINING LIFE

### LINING LIFE FORMULAE

#### Calculating Service Life of Lining(s)

The lining life per cubic inch shown by Figure 1 below is based on horsepower hours.

**FIGURE 1 – LINING MATERIAL LIFE (REPLACEABLE HIGH GRADE FRICTION MATERIAL - NON-ASBESTOS, ORGANIC)**

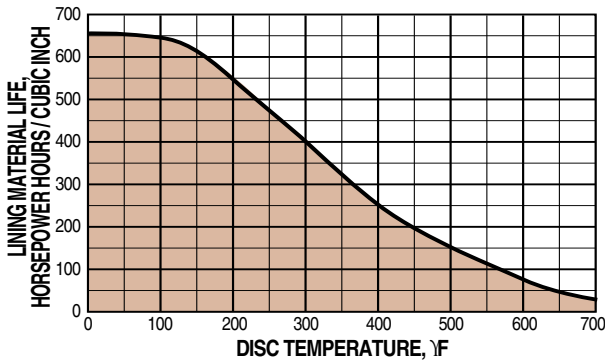

#### To find the life in hours of lining(s):

(Primarily for tensioning-constant slip applications)

$$\text{Ft-lbs/hr} = (\text{BTU/hr generated})(778) \quad [17]$$

Refer to Formula [12]

$$\text{HP hrs/hr} = \frac{\text{ft-lbs/hr}}{1,980,000} \quad [18]$$

Refer to Table 2 to determine cubic inches of wearable material of various caliper sizes.

$$\text{Life in Hours} = \frac{(\text{number of calipers}) \left( \frac{\text{cubic in.}}{\text{Table 2}} \right) (\text{HP hrs./in}^3 \text{ Figure 1})}{\text{HP hrs./hr.}} \quad [19]$$

To find the life of lining(s) in stops: When a rotating mass is brought to rest, the kinetic energy removed can be calculated by the following formulae:

$$E = \frac{\pi T N t}{60} \quad [20]$$

$$\text{or } E = \frac{W K^2 N^2}{5872} \quad [21]$$

Where:  $E$  = Kinetic Energy; ft-lbs

$$\text{HP hrs./Stop} = \frac{E}{1,980,000} \quad [22]$$

$$\text{Life in Stops} = \frac{(\text{number of calipers}) \left( \frac{\text{cubic in.}}{\text{Table 2}} \right) (\text{HP hrs./in}^3 \text{ Figure 1})}{\text{HP hrs./Stop}} \quad [23]$$

**LINING LIFE CALCULATIONS ARE ESTIMATES AND DO NOT ACCOUNT FOR FOREIGN CONTAMINANTS THAT MAY ABRASIVE THE LINING OR DISC AND REDUCE LIFE. WHEN THE LIFE MUST BE KNOWN ACCURATELY, FIELD TESTS SHOULD BE CONDUCTED UNDER ACTUAL OR SIMULATED SERVICE CONDITIONS.**

### TABLE 1 – DISC SPECIFICATIONS

DISC DIAMETER	EXPOSED AREA		WEIGHT*		MAXIMUM BTU / HR.	MAXIMUM JOULE/HR.
	IN <sup>2</sup>	SQ. FT.	SQ MM	LBS. KGS.		
6.313	62.58	0.43	40,374	1.37 0.62	283.8	299,360
8.000	100.53	0.70	64,858	3.52 1.60	462.0	487,329
10.000	157.08	1.09	101,342	5.46 2.48	719.4	758,842
12.000	226.20	1.57	145,935	7.91 3.59	1,036.0	1,092,799
16.000	402.12	2.79	259,432	14.06 6.38	1,841.4	1,942,356

\*BASED ON A STEEL DISC 1/4" THICK (EXCEPT FOR Ø6.313 WHICH IS BASED ON A STEEL DISC 5/32" THICK).

### TABLE 2 – CUBIC INCHES OF WEARABLE FRICTION MATERIAL

CALIPER SERIES	CUBIC INCHES	CALIPER SERIES	CUBIC INCHES	SERIES	INCHES
				FS440	1.75
10	.46	FS220		H441	3.71
20	.83	Aluminum	1.66	FS595	4.57
H220		FS220		H960	8.00
Aluminum	1.66	Cast Iron w/ JK options	2.35	MB3	6.06
H220		H440	3.32		
Cast Iron	2.35				

CALIPER CUBIC

### TABLE 3 – CAM TRAVEL DATA

#### ME10 and ME20 Calipers

- 15° maximum travel when linings are new and with 1/32" gap each side of disc.
- Periodic tightening of lock nut will reduce travel of lever and will allow 1/4" wear on each lining.
- 90° maximum travel after 3/16" wear on each lining without intermediate tightening of lock nut.

#### ME220 Calipers

- Gap between lining faces and disc when new = .048" total.
- Angular movement required to actuate brake when new = 7° 30".
- Maximum axial movement without intermediate adjustment = .387".
- Wear allowed before adjustment .104" each side.

#### MB3 Calipers

- 0° travel with .500" disc.
- 90° maximum travel after .125" wear on each side of lining without intermediate tightening of the lock nut.

## SELECTION: FORMULAE: VEHICULAR

### VEHICULAR APPLICATIONS FORMULAE

#### Calculation of Torque Required

$$\text{Dynamic } T = \frac{WR \left[ \frac{a}{g} + \frac{b}{100} \right]}{(D)} \quad [24]$$

- Where:
- T** = Torque per Axle, vehicle, or wheel; in-lbs
  - W** = Weight on axle including weight transfer, if any, vehicle or wheel; lbs.
  - R** = Loaded tire radius; in.
  - g** = 32.2 ft./sec<sup>2</sup>
  - b** = % of grade
  - D** = Gear Reduction, if drive line mounted
  - a** = Deceleration rate; ft/sec<sup>2</sup>

And

$$a = \frac{V}{t} = \frac{V^2}{2S} \quad [25]$$

- Where:
- V** = Velocity of vehicle, ft./sec., at moment of brake application
  - t** = Stopping time required; seconds
  - S** = Stopping distance of vehicle; ft.

$$\text{Parking } T = \frac{WR \left[ \frac{b}{100} \right]}{D} \quad [26]$$

#### Calculation of Heat Generation and Required Dissipation (Vehicular)

$$E = \frac{WV^2}{2g} \quad [27]$$

- Where:
- E** = Kinetic Energy; ft-lbs
  - W** = Weight of axle, vehicle, or wheel; lbs.
  - V** = Design speed of vehicle; ft/sec.

$$\text{BTU/hr. generated} = \frac{(E) \left( \frac{\text{stopping frequency/hr.}}{778} \right)}{778} \quad [28]$$

Then solving for the number of square feet of exposed disc area to dissipate the heat generated:

$$\text{Sq. Ft. Disc Area} = \frac{\text{BTU/hr}}{660} \quad [14]$$

The constant of 660 is based on a maximum disc temperature of 300°F.

If there is a restriction in the disc diameter(s) and there is sufficient time between stops or multiple of stops for heat dissipation then we can size the disc to act as a heat sink.

$$Wd = \frac{\text{BTU/hr.}}{(220)(Sp)} \quad [9]$$

- Where:
- Wd** = Weight of disc; lbs.
  - Sp** = Specific heat of disc may be taken as .12 for steel; BTU/lbs-°F

Refer to Table 1 (page 94) for selection. If your requirement falls outside of the standard(s) you may calculate the required thickness based on the maximum allowable diameter:

$$\text{Disc Thickness} = \frac{Wd}{(A)(.28)} \quad [10]$$

- Where:
- Thickness is in inches
  - A** = Area of maximum allowable diameter; in<sup>2</sup>

If it is found the disc thickness is unrealistic from an economic or space limitation standpoint, multiple discs will have to be provided or force ventilation must be considered.



## APPLICATION DATA WORKSHEET

- FEATURES
- APPLICATIONS
- SELECTION GRAPHS
- PNEUMATIC BRAKES
- P10
- P20
- P220
- HYDRAULIC BRAKES
- H10
- H20
- H220
- H441
- H960
- HYDRAULIC/MECHANICAL BRAKE COMBOS
- H/ME20
- H/ME220
- MECHANICAL BRAKES
- ME10
- ME20
- ME220
- MB3
- SPRING APPLIED BRAKES
- FS20
- FS220
- FS220I
- FS395
- DISCS HUBS & BUSHINGS
- TENSION CONTROL COMBINATIONS
- INTENSIFIER
- SELECTION
- WORKSHEET

Use this form to request engineering assistance. The data you furnish will enable us to understand your application and recommend\* the proper braking equipment. When available, please attach prints or dimensional drawings. **For best results copy this page first then fax to: (763) 478-8080 or Mail to: Tolomatic, 3800 County Road 116, Hamel, MN 55340**

NAME: \_\_\_\_\_  
 TITLE: \_\_\_\_\_  
 FIRM: \_\_\_\_\_  
 ADDRESS: \_\_\_\_\_  
 CITY: \_\_\_\_\_  
 STATE: \_\_\_\_\_ ZIP: \_\_\_\_\_  
 PHONE: ( \_\_\_\_\_ ) \_\_\_\_\_  
 FAX: ( \_\_\_\_\_ ) \_\_\_\_\_

TYPE OF EQUIPMENT BRAKES WILL BE USED ON:  
 \_\_\_\_\_  
 \_\_\_\_\_  
 \_\_\_\_\_  
 \_\_\_\_\_  
 MODEL: \_\_\_\_\_ PROJECT #: \_\_\_\_\_

### A. VEHICLE SPECIFICATIONS

PLEASE CONTACT FACTORY

### B. TENSIONING DATA

\_\_\_\_\_  
 \_\_\_\_\_  
 \_\_\_\_\_  
 \_\_\_\_\_  
 \_\_\_\_\_  
 \_\_\_\_\_  
 \_\_\_\_\_  
 \_\_\_\_\_  
 \_\_\_\_\_  
 \_\_\_\_\_  
 \_\_\_\_\_  
 \_\_\_\_\_  
 \_\_\_\_\_  
 \_\_\_\_\_  
 \_\_\_\_\_  
 \_\_\_\_\_  
 \_\_\_\_\_  
 \_\_\_\_\_  
 \_\_\_\_\_  
 \_\_\_\_\_  
 \_\_\_\_\_

### C. STATIONARY EQUIPMENT SPECIFICATIONS

CYCLIC STOPS?  Yes  No  
 W = Weight of rotating member, lbs.  
 R = Radius of rotating member, ft.  
 WK² OF ROTATING PARTS \_\_\_\_\_ @RPM \_\_\_\_\_  
 DECELERATION NEEDED:  
 Time \_\_\_\_\_ seconds from \_\_\_\_\_ RPM  
 \_\_\_\_\_ Radians per sec.<sup>2</sup>  
 RELEASE PRESSURE FOR SPRING-APPLIED BRAKES ..... \_\_\_\_\_ psi

### D. GENERAL APPLICATION DATA

FREQUENCY OF STOPS: ..... \_\_\_\_\_  
 COMPLETE OPERATING CYCLE: ..... \_\_\_\_\_  
 MAXIMUM ALLOWABLE DISC DIAMETER: ..... in.  
 MAXIMUM ALLOWABLE DISC THICKNESS: ..... in.  
 TYPE OF ACTUATION:  Mechanical  Spring Applied  
 Pneumatic  Hydraulic  
 MAXIMUM HYDRAULIC OR AIR PRESSURE: ..... psi  
 BACK PRESSURE: ..... psi  
 DRIVE SHAFT APPLICATIONS ONLY:  
 Gear ratio is \_\_\_\_\_ in favor of \_\_\_\_\_, or against \_\_\_\_\_ the brake  
 AVAILABLE DISPLACEMENT: ..... in.<sup>3</sup>  
 TYPE OF FLUID: \_\_\_\_\_ MAXIMUM TORQUE: \_\_\_\_\_ in.-lbs.  
 AMBIENT TEMPERATURES TO BE ENCOUNTERED: ..... °F  
 LINING LIFE DESIRED: ..... \_\_\_\_\_  
 LEVER FORCE AVAILABLE: ..... lbs.

### E. ADDITIONAL COMMENTS

\_\_\_\_\_  
 \_\_\_\_\_  
 \_\_\_\_\_  
 \_\_\_\_\_  
 \_\_\_\_\_  
 \_\_\_\_\_  
 \_\_\_\_\_  
 \_\_\_\_\_

\* Recommendation is based on information supplied by the customer. Final acceptance and approval is the responsibility of the customer after field testing or simulation of field testing on the machine it is designed for.



3800 County Road 116 • Hamel, MN 55340  
 Telephone: (763) 478-8000 • Fax: (763) 478-8080



## **Disc Cone Clutch**

Pages 98 through 109

Visit [www.tolomatic.com](http://www.tolomatic.com) for the latest updates and ordering.

## **APPLICATIONS**



Tolomatic Disc Cone clutches have been used in thousands of applications since their introduction nearly 50 years ago. Often used in conjunction with Tolomatic caliper disc brakes and Float-A-Shaft for complete control over

power transmission in OEM machines and automated assembly lines. These pictures show clutches being used in material handling, packaging machinery, a lathe and an assembly line.

## SELECTION GRAPH

### PERFORMANCE DATA - TRANSMITTED POWER vs RPM

#### Disc Cone Clutches

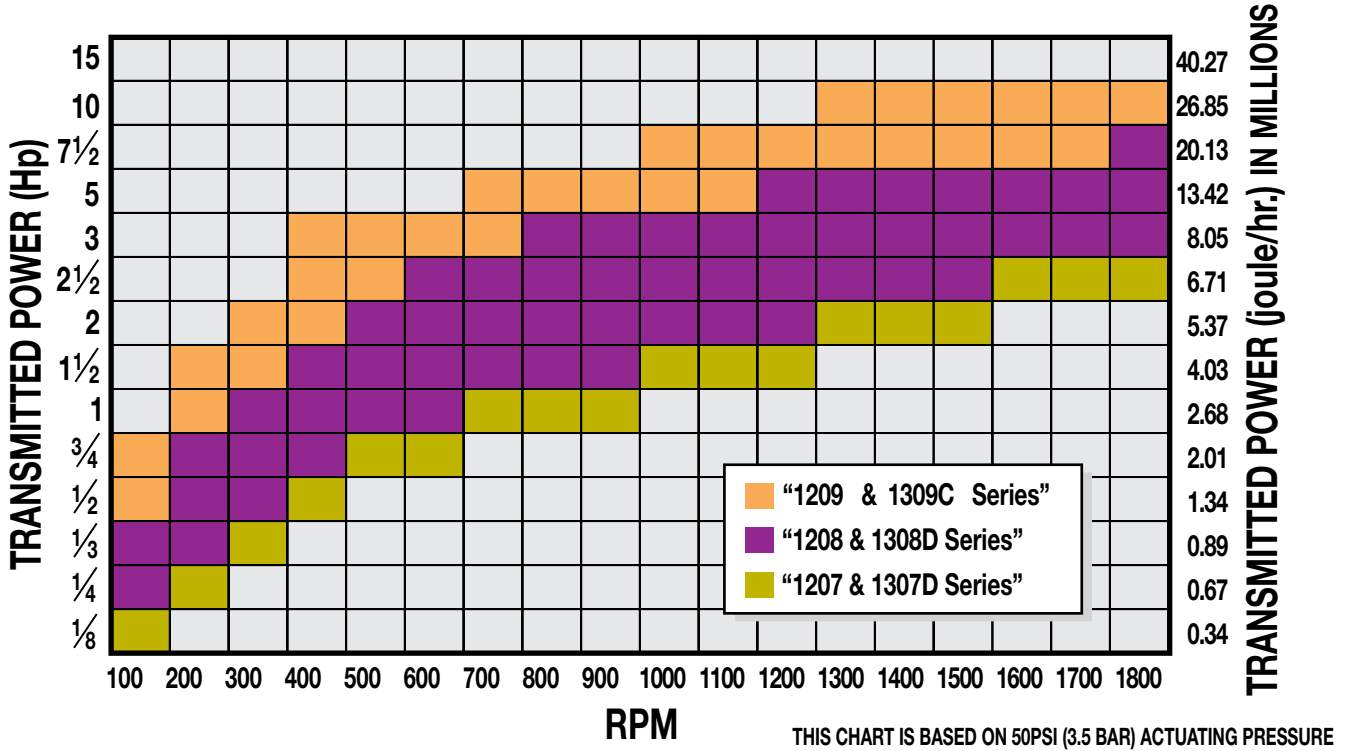

## FEATURES

### THE ONLY DISC CONE CLUTCH IN THE INDUSTRY

Tolomatic engineers developed the Disc/Cone clutch more than 40 years ago, and it's still the only disc/cone clutch available in the industry today. In this unique design the cone engages a cup on the pilot plate for immediate, positive engagement with no slippage. Tolomatic Disc/Cone Clutches offer high torque and compact profiles in lower cyclic applications.

The Disc/Cone clutch is available in two models; the 1200 series and the 1300 series.

The 1300 series offers a space saving design, while the 1200 series has a cast iron, heat dissipating finned plate which gives it almost 10 times the heat dissipating capacity of the 1300 series model.

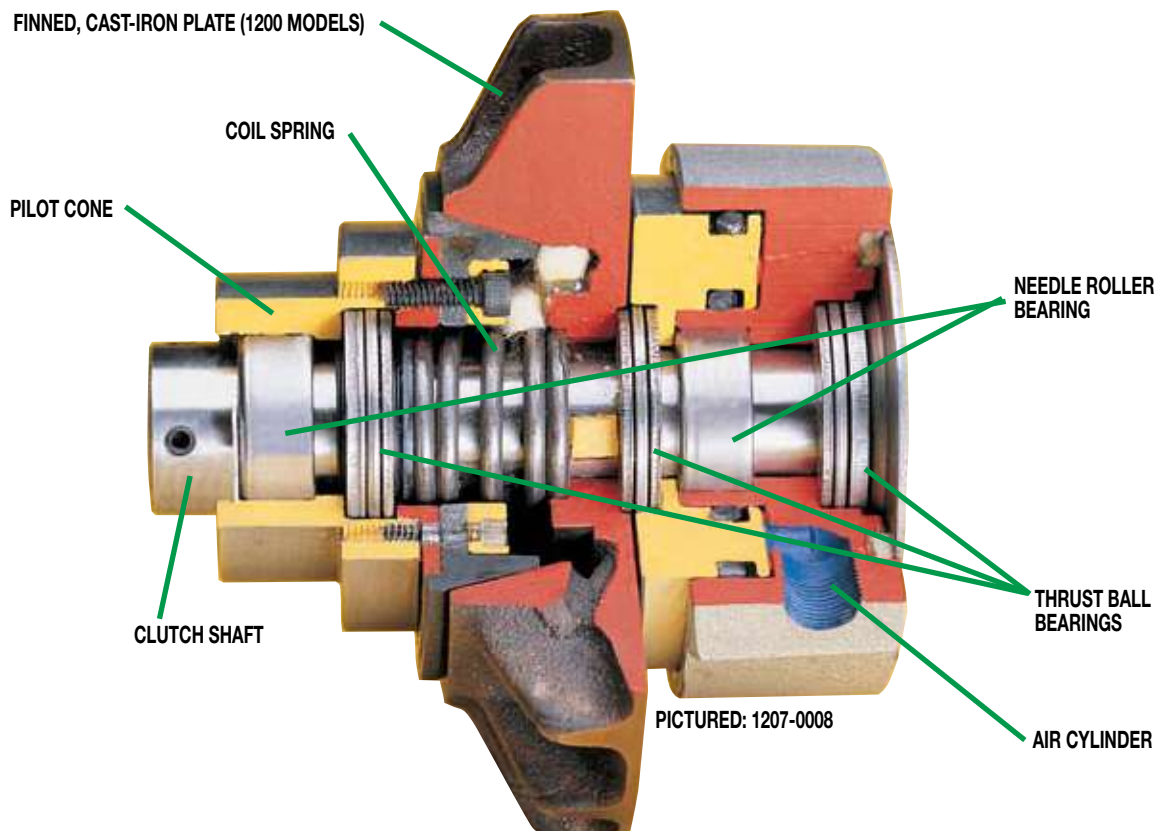

- DISC-PLATE, PILOT-MOUNT DESIGN
- HIGH TORQUE
- NO SLIPPAGE
- SPACE-SAVING DESIGN
- FAST RESPONSE BASED ON LOW AIR CONSUMPTION

## 1207, 1307D SERIES

### AVAILABLE STYLES

#### 1207 Series



PICTURED: 1207-0008

#### 1307D Series



PICTURED: 1307-0308

### 1207 & 1307D

#### Performance Data

#### Torque vs Pressure - 1207, 1307D

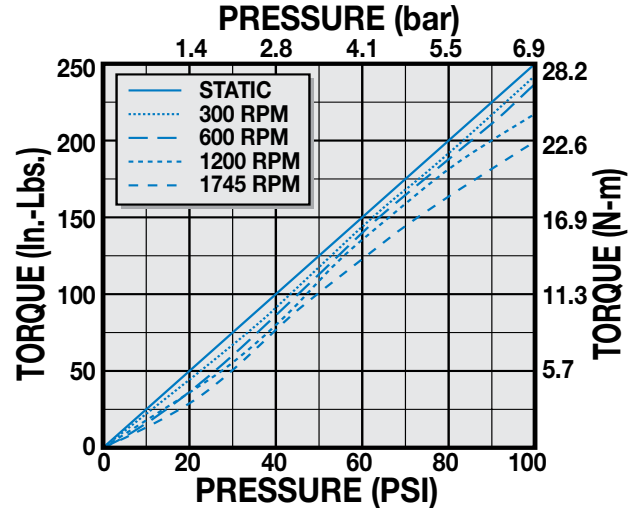

### 1207 SERIES

#### Specifications

ASSEMBLY NUMBER	DESCRIPTION	BORE SIZE	BASE WEIGHT	FREE AIR CONSUMPTION		MAX. PRESSURE
				NEW	WORN	
1207-0008	Clutch 1207-08	1/2" 12.7mm	4.0 lbs. 1.81 kg.	0.24 cu.in. 3.9 ml	1.09 cu.in. 17.9 ml	100 PSI 6.9bar
1207-0010	Clutch 1207-10	5/8" 15.9mm	4.0 lbs. 1.81 kg.	0.24 cu.in. 3.9 ml	1.09 cu.in. 17.9 ml	100 PSI 6.9bar

#### Performance data

#### RPM vs Torque at various cycle rates

RPM	CYCLE RATES (CPM)									
	1	3	5	10	15	20	25	30	35	40
300	247	247	247	247	247	247	247	247	247	247
600	240	240	240	240	240	240	240	240	240	180
1200	220	220	220	220	220	220	220	203	180	160
1745	200	200	200	200	200	200	160	143	123	105

TORQUE (IN.-LBS.)

### 1307D SERIES

#### Specifications

ASSEMBLY NUMBER	DESCRIPTION	BORE SIZE	BASE WEIGHT	FREE AIR CONSUMPTION		MAX. PRESSURE
				NEW	WORN	
1307-0308	Clutch 1307D-08	1/2" 12.7mm	3.1 lbs. 1.41 kg.	0.24 cu.in. 3.9 ml	1.09 cu.in. 17.9 ml	100 PSI 6.9bar
1307-0310	Clutch 1307D-10	5/8" 15.9mm	3.1 lbs. 1.41 kg.	0.24 cu.in. 3.9 ml	1.09 cu.in. 17.9 ml	100 PSI 6.9bar

#### Performance data

#### RPM vs Torque at various cycle rates

RPM	CYCLE RATES (CPM)									
	1	3	5	10	15	20	25	30	35	40
300	247	247	247	247	247	247	247	247	247	222
600	240	240	240	240	240	240	240	240	190	177
1200	220	220	220	220	190	65	37			
1745	200	200	200	57	35					

TORQUE (IN.-LBS.)



## 1207, 1307D SERIES

### 1207 & 1307D

#### Performance Data Response Times - 1207, 1307D

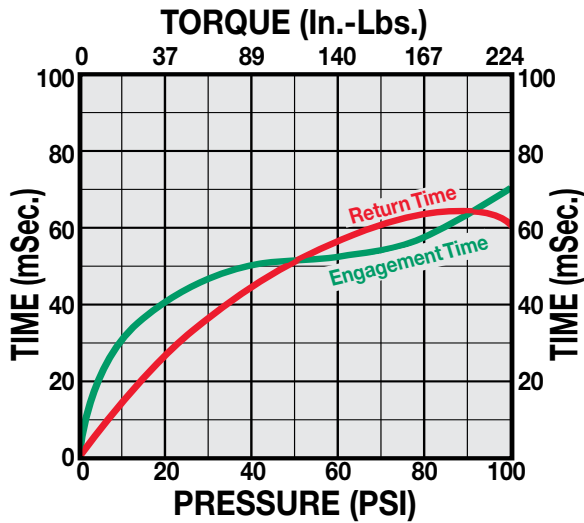

### 1207 ONLY

#### Performance Data Heat Dissipation - (1207 only)

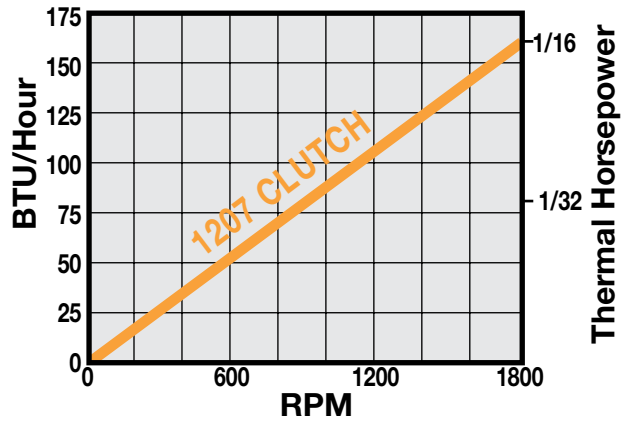

### 1207 SERIES

#### Dimensional Data

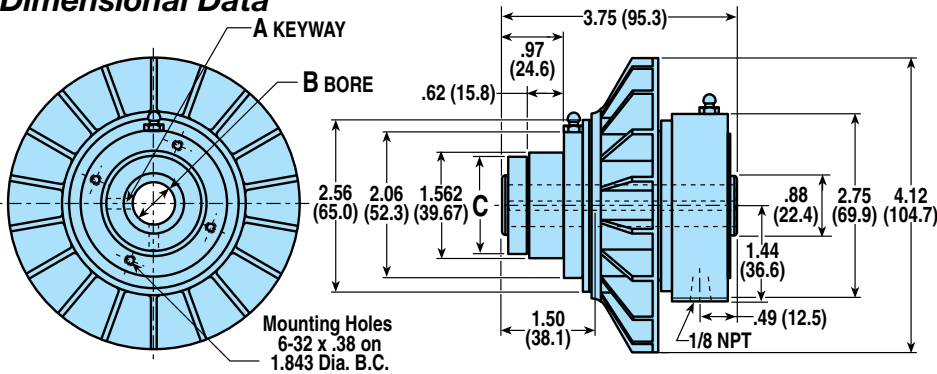

ASSEMBLY NUMBER	A	B BORE DIAMETER	C
1207-0008	1/8" x 1/16"	.50" (12.7mm)	-
1207-0010	3/16" x 1/16"	.625" (15.88mm)	1.38" (35.1mm)

### 1307D SERIES

#### Dimensional Data

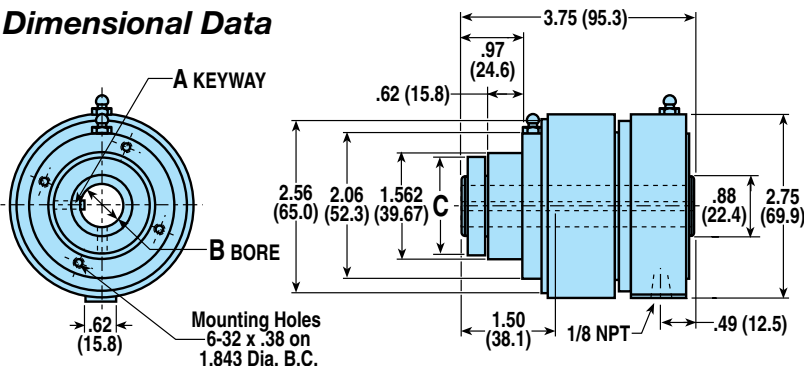

ASSEMBLY NUMBER	A	B BORE DIAMETER	C
1307-0308	1/8" x 1/16"	.50" (12.7mm)	-
1307-0310	3/16" x 1/16"	.625" (15.88mm)	1.38" (35.1mm)

# Disc Cone Clutch

## 1208, 1308D SERIES

### AVAILABLE STYLES

#### 1208 Series



PICTURED: 1208-0010

#### 1308D Series



PICTURED: 1308-0310

### 1208 & 1308D

#### Performance Data

#### Torque vs Pressure - 1208, 1308D

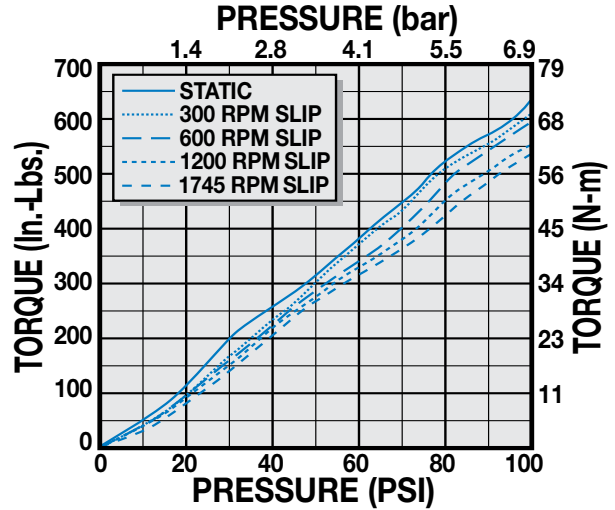

### 1208 SERIES

#### Specifications

ASSEMBLY NUMBER	DESCRIPTION	BORE SIZE	BASE WEIGHT	FREE AIR CONSUMPTION		MAX. PRESSURE
				NEW	WORN	
1208-0010	Clutch 1208-10	5/8" 15.9mm	8.0 lbs. 3.63 kg.	0.50 cu.in. 8.2 ml	2.65 cu.in. 43.4 ml	100 PSI 6.9bar
1208-0012	Clutch 1208-12	3/4" 19.1mm	8.0 lbs. 3.63 kg.	0.50 cu.in. 8.2 ml	2.65 cu.in. 43.4 ml	100 PSI 6.9bar
1208-0014	Clutch 1208-14	7/8" 22.2mm	8.0 lbs. 3.63 kg.	0.50 cu.in. 8.2 ml	2.65 cu.in. 43.4 ml	100 PSI 6.9bar

#### Performance data

#### RPM vs Torque at various cycle rates

RPM	CYCLE RATES (CPM)									
	1	3	5	10	15	20	25	30	35	40
300	635	635	635	635	635	635	635	635	635	635
600	600	600	600	600	600	600	600	600	550	475
1200	560	560	560	450	330	275	150	85		
1745	430	370	315	205	80	50	35			

TORQUE (IN.-LBS.)

### 1308D SERIES

#### Specifications

ASSEMBLY NUMBER	DESCRIPTION	BORE SIZE	BASE WEIGHT	FREE AIR CONSUMPTION		MAX. PRESSURE
				NEW	WORN	
1308-0310	Clutch 1308D-10	5/8" 15.9mm	8.0 lbs. 3.63 kg.	0.50 cu.in. 8.2 ml	2.65 cu.in. 43.4 ml	100 PSI 6.9bar
1308-0312	Clutch 1308D-12	3/4" 19.1mm	8.0 lbs. 3.63 kg.	0.50 cu.in. 8.2 ml	2.65 cu.in. 43.4 ml	100 PSI 6.9bar
1308-0314	Clutch 1308D-14	7/8" 22.2mm	8.0 lbs. 3.63 kg.	0.50 cu.in. 8.2 ml	2.65 cu.in. 43.4 ml	100 PSI 6.9bar

#### Performance data

#### RPM vs Torque at various cycle rates

RPM	CYCLE RATES (CPM)									
	1	3	5	10	15	20	25	30	35	40
300	635	635	635	635	635	635	635	635	635	635
600	600	600	600	600	405	290	225	155	80	40
1200	505	380	275	85						
1745	315	35								

TORQUE (IN.-LBS.)

# Disc Cone Clutch

## 1208, 1308D SERIES

### 1208 & 1308D

#### Performance Data

#### Response Times - 1208, 1308D

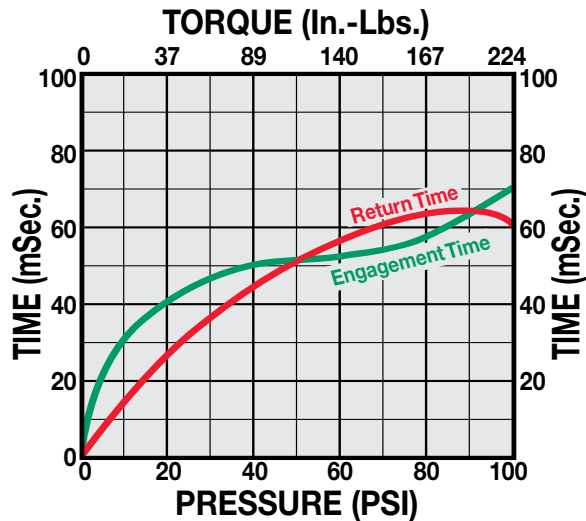

### 1208 ONLY

#### Performance Data

#### Heat Dissipation - (1208 only)

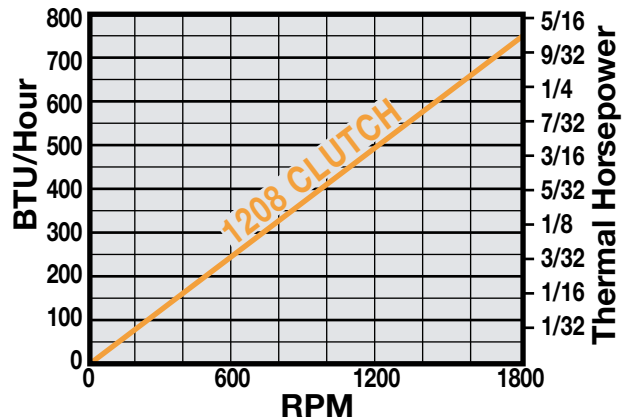

## 1208 SERIES

#### Dimensional Data

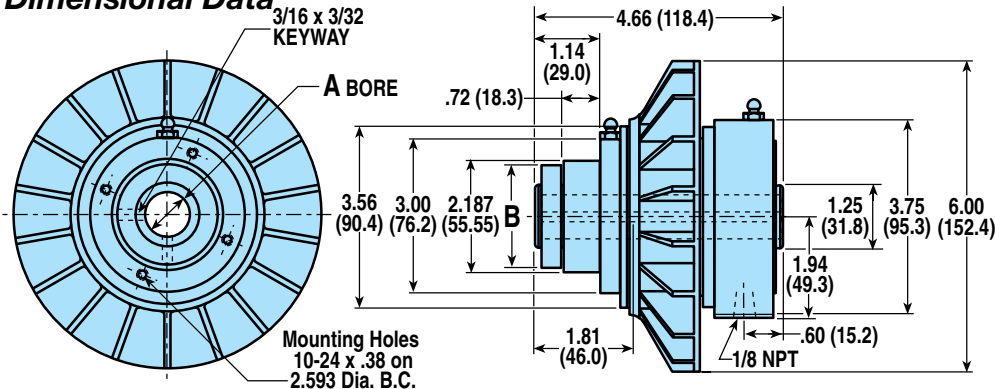

ASSEMBLY NUMBER	A BORE DIAMETER	B
1208-0010	.625" (15.88mm)	—
1208-0012	.75" (19.1mm)	—
1208-0014	.875" (22.23mm)	2.00" (50.8mm)

## 1308D SERIES

#### Dimensional Data

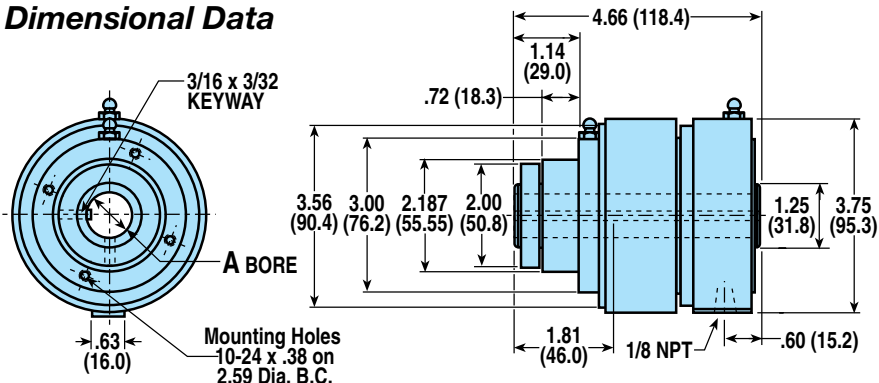

ASSEMBLY NUMBER	A BORE DIAMETER
1308-0310	.625" (15.88mm)
1308-0312	.75" (19.1mm)
1308-0314	.875" (22.23mm)

DISC CONE CLUTCHES

INTRODUCTION

APPLICATIONS

SELECTION GRAPH

FEATURES

1207-1307D SERIES

1208-1308D SERIES

1209-1309C SERIES

OPTIONAL COMBINATIONS

SELECTION

## 1209, 1309C SERIES

### AVAILABLE STYLES

#### 1209 Series



PICTURED: 1209-0016

#### 1309C Series



PICTURED: 1309-0316

### 1209 & 1309C

#### Performance Data

#### Torque vs Pressure - 1209, 1309C

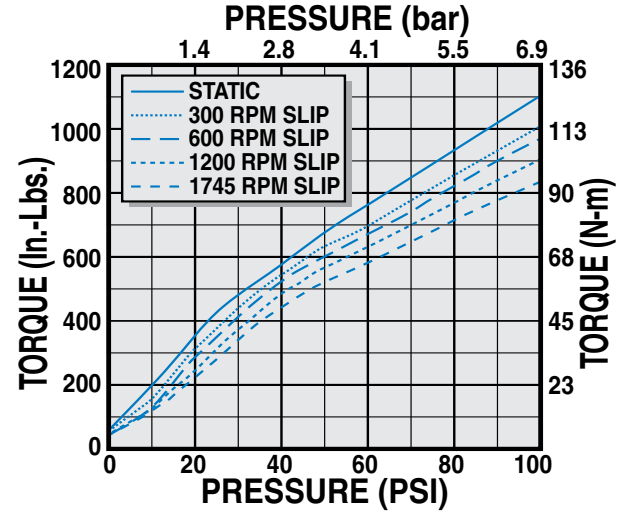

### 1209 SERIES

#### Specifications

ASSEMBLY NUMBER	DESCRIPTION	BORE SIZE	BASE WEIGHT	FREE AIR CONSUMPTION NEW	FREE AIR CONSUMPTION WORN	MAX. PRESSURE
1209-0016	Clutch 1209-16	1" 25.4mm	17.0 lbs. 7.71 kg.	0.55 cu.in. 9.0 ml	3.48 cu.in. 57.0 ml	100 PSI 6.9bar
1209-0018	Clutch 1209-18	1-1/8" 28.6mm	17.0 lbs. 7.71 kg.	0.55 cu.in. 9.0 ml	3.48 cu.in. 57.0 ml	100 PSI 6.9bar
1209-0020	Clutch 1209-20	1-1/4" 31.8mm	17.0 lbs. 7.71 kg.	0.55 cu.in. 9.0 ml	3.48 cu.in. 57.0 ml	100 PSI 6.9bar
1209-0022	Clutch 1209-22	1-3/8" 34.9mm	17.0 lbs. 7.71 kg.	0.55 cu.in. 9.0 ml	3.48 cu.in. 57.0 ml	100 PSI 6.9bar

#### Performance data

#### RPM vs Torque at various cycle rates

RPM	CYCLE RATES (CPM)									
	1	3	5	10	15	20	25	30	35	40
300	1000	1000	1000	1000	1000	1000	1000	1000	1000	1000
600	960	960	960	960	960	960	960	960	885	810
1200	900	900	900	900	900	900	725	560	425	
1750	830	830	760	550	360	220				

### 1309C SERIES

#### Specifications

ASSEMBLY NUMBER	DESCRIPTION	BORE SIZE	BASE WEIGHT	FREE AIR CONSUMPTION NEW	FREE AIR CONSUMPTION WORN	MAX. PRESSURE
1309-0316	Clutch 1309C-16	1" 25.4mm	17.0 lbs. 7.71 kg.	0.55 cu.in. 9.0 ml	3.48 cu.in. 57.0 ml	100 PSI 6.9bar
1309-0318	Clutch 1309C-18	1-1/8" 28.6mm	17.0 lbs. 7.71 kg.	0.55 cu.in. 9.0 ml	3.48 cu.in. 57.0 ml	100 PSI 6.9bar
1309-0320	Clutch 1309C-20	1-1/4" 31.8mm	17.0 lbs. 7.71 kg.	0.55 cu.in. 9.0 ml	3.48 cu.in. 57.0 ml	100 PSI 6.9bar
1309-0322	Clutch 1309C-22	1-3/8" 34.9mm	17.0 lbs. 7.71 kg.	0.55 cu.in. 9.0 ml	3.48 cu.in. 57.0 ml	100 PSI 6.9bar

#### Performance data

#### RPM vs Torque at various cycle rates

RPM	CYCLE RATES (CPM)									
	1	3	5	10	15	20	25	30	35	40
300	1000	1000	1000	1000	1000	960	855	725	660	585
600	960	960	960	700	470	270	200			
1200	650	550	425							
1750	430	210								

## 1209, 1309C SERIES

### 1209 & 1309C

#### Performance Data

#### Response Times - 1209, 1309C

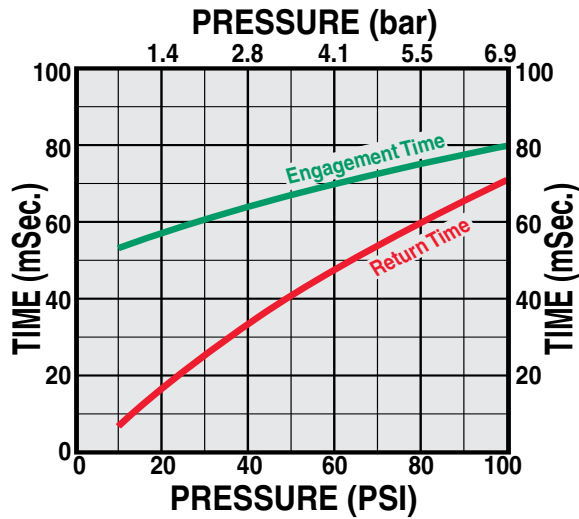

### 1209 ONLY

#### Performance Data

#### Heat Dissipation - (1209 only)

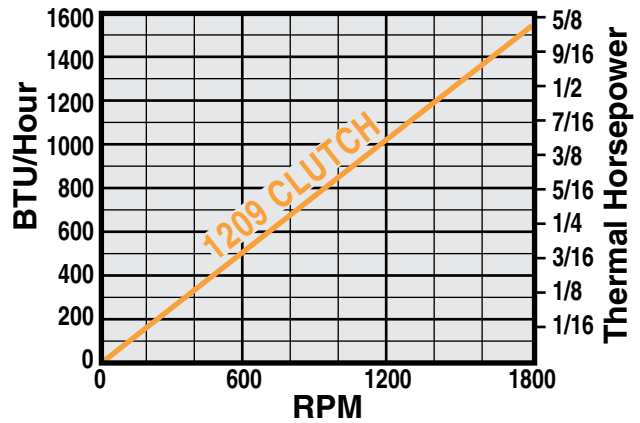

## 1209 SERIES

#### Dimensional Data

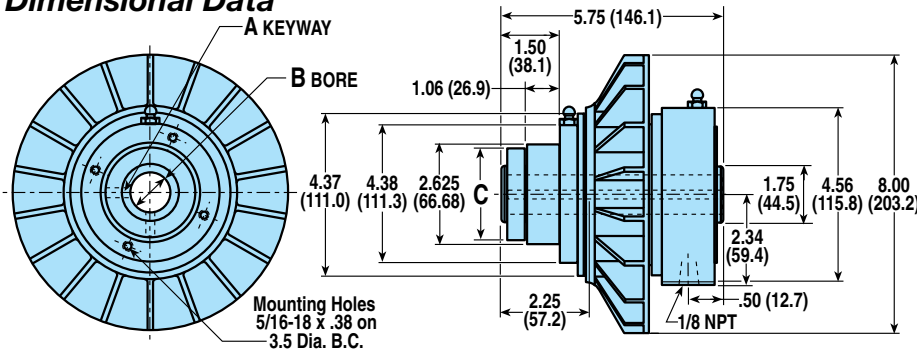

ASSEMBLY NUMBER	A	B BORE DIAMETER	C
1209-0016	1/4" x 1/8"	1.00" (25.4mm)	-
1209-0018	1/4" x 1/8"	1.125" (28.58mm)	-
1209-0020	1/4" x 1/8"	1.25" (31.8mm)	-
1209-0022	5/16" x 1/8"	1.375" (34.93mm)	2.50" (63.5mm)

## 1309C SERIES

#### Dimensional Data

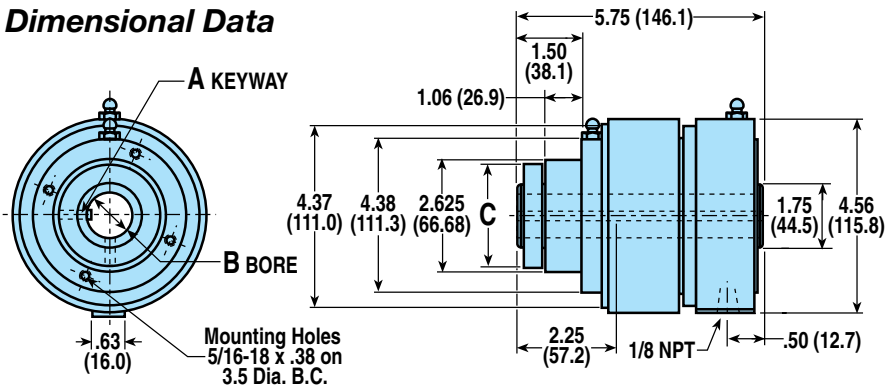

ASSEMBLY NUMBER	A	B BORE DIAMETER	C
1309-0316	1/4" x 1/8"	1.00" (25.4mm)	-
1309-0318	1/4" x 1/8"	1.125" (28.58mm)	-
1309-0320	1/4" x 1/8"	1.25" (31.8mm)	-
1309-0322	5/16" x 5/32"	1.375" (34.93mm)	2.50" (63.5mm)



## SPROCKET COMBINATIONS

### AVAILABLE STYLES

**Sprocket Mount**

**Sprocket Mount with Disc and Brake**



PICTURED: 1310-0122

PICTURED: 1507-0010

Sprocket sizes from 35A25 to 50A27, also available in combination with a P20DA or P220DA brake.

### SPECIFICATIONS & PERFORMANCE

Refer to page 100 for DCC 1207 & 1307D specifications and performance data

Refer to page 102 for DCC 1208 & 1308D specifications and performance data

Refer to page 104 for DCC 1209 & 1309C specifications and performance data

Refer to page 34 for P20DA caliper disc brake specifications and performance data

Refer to page 36 for P220DA caliper disc brake specifications and performance data

Refer to page 80 for disc specifications and performance data

### "13" CLUTCH & SPROCKET

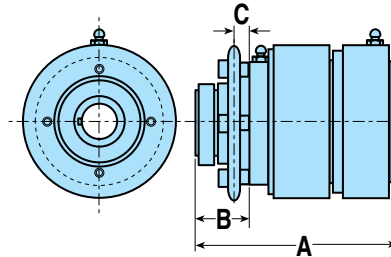

ASSY NO.	CLUTCH	SPROCKET	A	B	C
1607-0108	1307D-08	35A25	3.75"	0.97"	0.40"
1607-0110	1307D-10	35A25	3.75"	0.97"	0.40"
1608-0110	1308D-10	40A22	4.66"	1.14"	0.47"
1608-0112	1308D-12	40A22	4.66"	1.14"	0.47"
1608-0114	1308D-14	40A22	4.66"	1.14"	0.47"
1609-0116	1309C-16	40A28	5.75"	1.50"	0.48"
1609-0118	1309C-18	40A28	5.75"	1.50"	0.48"
1609-0120	1309C-20	40A28	5.75"	1.50"	0.48"
1609-0122	1309C-22	40A28	5.75"	1.50"	0.48"
1609-0216	1309C-16	50A27	5.75"	1.50"	0.51"
1609-0218	1309C-18	50A27	5.75"	1.50"	0.51"
1609-0220	1309C-20	50A27	5.75"	1.50"	0.51"
1609-0222	1309C-22	50A27	5.75"	1.50"	0.51"

### "12" CLUTCH & SPROCKET

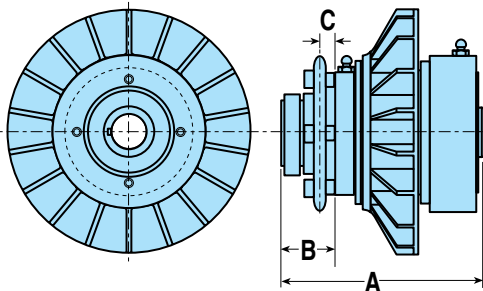

ASSY NO.	CLUTCH	SPROCKET	A	B	C
1507-0108	1207-08	35A25	3.75"	0.97"	0.40"
1507-0110	1207-10	35A25	3.75"	0.97"	0.40"
1508-0110	1208-10	40A22	4.66"	1.14"	0.47"
1508-0112	1208-12	40A22	4.66"	1.14"	0.47"
1508-0114	1208-14	40A22	4.66"	1.14"	0.47"
1509-0116	1209-16	40A28	5.75"	1.50"	0.48"
1509-0118	1209-18	40A28	5.75"	1.50"	0.48"
1509-0120	1209-20	40A28	5.75"	1.50"	0.48"
1509-0122	1209-22	40A28	5.75"	1.50"	0.48"
1509-0216	1209-16	50A27	5.75"	1.50"	0.51"
1509-0218	1209-18	50A27	5.75"	1.50"	0.51"
1509-0220	1209-20	50A27	5.75"	1.50"	0.51"
1509-0222	1209-22	50A27	5.75"	1.50"	0.51"

## SPROCKET & BRAKE COMBINATIONS

### "12" CLUTCH, SPROCKET, DISC AND P20 BRAKE

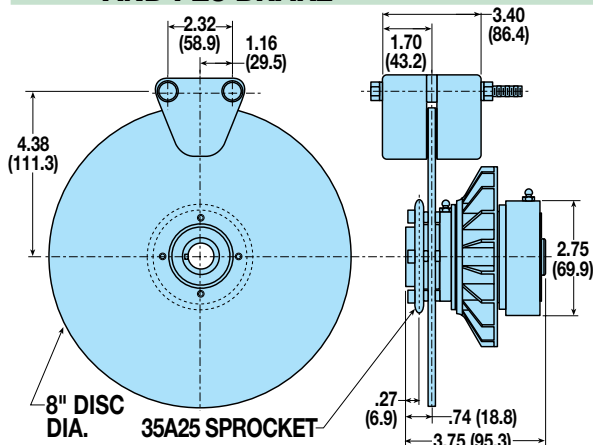

ASSY. NO.	CLUTCH	CALIPER	DISC DIA.	SPROCKET
1507-0608	1207-08	P20DA	8 in.	35A25
1507-0610	1207-10	P20DA	8 in.	35A25

### "13" CLUTCH, SPROCKET, DISC AND P20 BRAKE

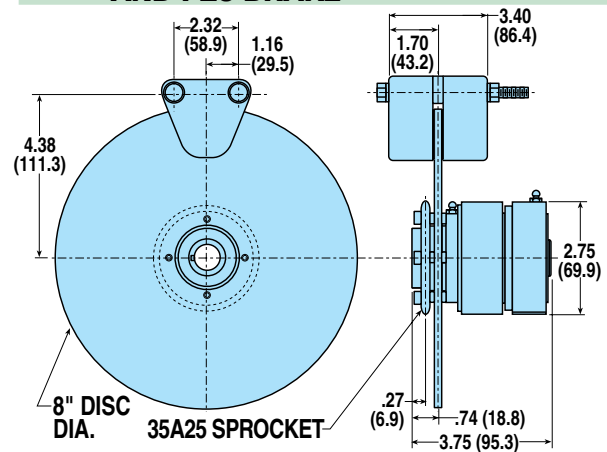

ASSY. NO.	CLUTCH	CALIPER	DISC DIA.	SPROCKET
1607-0608	1307D-08	P20DA	8 in.	35A25
1607-0610	1307D-10	P20DA	8 in.	35A25

### "12" CLUTCH, SPROCKET, DISC AND P220 BRAKE

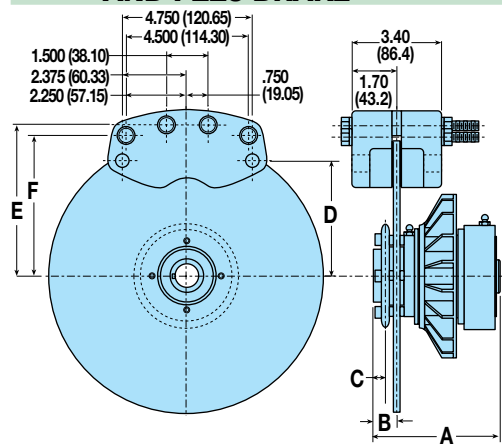

"12" SERIES										"13" SERIES	
ASSY. NO.	CLUTCH	CALIPER	DISC DIA.	A	B	C	D	E	F	CLUTCH	ASSY. NO.
1508-0510	1208-10	P220DA	10"	4.66"	0.91"	0.36"	4.00"	5.31"	4.94"	1308D-10	1608-0510
1508-0512	1208-10	P220DA	10"	4.66"	0.91"	0.36"	4.00"	5.31"	4.94"	1308D-12	1608-0512
1508-0514	1208-10	P220DA	10"	4.66"	0.91"	0.36"	4.00"	5.31"	4.94"	1308D-14	1608-0514
1509-0516	1209-16	P220DA	12"	5.75"	1.27"	0.71"	5.00"	6.31"	5.94"	1309C-16	1609-0516
1509-0518	1209-18	P220DA	12"	5.75"	1.27"	0.71"	5.00"	6.31"	5.94"	1309C-18	1609-0518
1509-0520	1209-20	P220DA	12"	5.75"	1.27"	0.71"	5.00"	6.31"	5.94"	1309C-20	1609-0520
1509-0522	1209-22	P220DA	12"	5.75"	1.27"	0.71"	5.00"	6.31"	5.94"	1309C-22	1609-0522
1509-0616	1209-16	P220DA	12"	5.75"	1.27"	0.49"	5.00"	6.31"	5.94"	1309C-16	1609-0616
1509-0618	1209-18	P220DA	12"	5.75"	1.27"	0.49"	5.00"	6.31"	5.94"	1309C-18	1609-0618
1509-0620	1209-20	P220DA	12"	5.75"	1.27"	0.49"	5.00"	6.31"	5.94"	1309C-20	1609-0620
1509-0622	1209-22	P220DA	12"	5.75"	1.27"	0.49"	5.00"	6.31"	5.94"	1309C-22	1609-0622

### "13" CLUTCH, SPROCKET, DISC AND P220 BRAKE

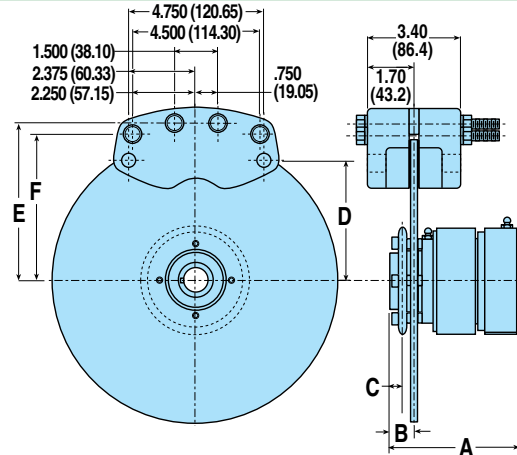

## SELECTION

- INTRODUCTION
- APPLICATIONS
- SELECTION GRAPH
- FEATURES
- 1207-1307D SERIES
- 1208-1308D SERIES
- 1209-1309C SERIES
- OPTIONAL COMBINATIONS
- SELECTION

### COMPILE APPLICATION REQUIREMENTS

To determine the appropriate Tolomatic clutch for an application compile the following information:

1. Available operating pressure
2. Input power shaft size
3. Starting time (seconds) required
4. Weight (lbs.) and radii (ft.) of the rotating members
5. Speed (RPM)
6. Rotation reductions in multi-shaft systems
7. Cycle Rate/Hr.

### CALCULATE THE TORQUE REQUIRED

Calculate the required torque for your application using the formula:

$$T = \frac{WK^2N}{308t}$$

(see page 109 for complete instructions to calculate torque).

### CALCULATE THE HEAT DISSIPATION REQUIRED

When a clutch is engaged, some degree of slippage occurs which generates heat. The clutch must be properly sized so that it can not only transmit the torque required, but also dissipate the heat generated and maintain a clutch temperature within acceptable operating limits for the friction material (300° F). Calculate heat generated (which must then be dissipated) using the formula:

$$E = \frac{WK^2N^2}{5872} \quad \text{or} \quad E = \frac{\pi TNt}{60}$$

(see page 109 for complete

instructions for energy calculations).

### SELECT THE CLUTCH SIZE AND TYPE

Begin the selection once the torque and energy calculations have been completed. Consult the Torque vs Pressure charts on page 98 or the Torque vs Pressure chart on for each size clutch.

Cross reference torque required and the available operating pressure. If the intersection falls below the diagonal line the clutch will accommodate the torque required for the application.

Next, consult the Heat Dissipation chart for the same clutch. (Heat Dissipation charts are on pages 101 to 105.)

Cross reference the BTU/hr. and the RPM at which the application will run. If the intersection falls below the line the clutch will accommodate the application. If the intersection is above the line, a clutch with higher heat dissipation should be considered. Now, simply select the bore size that fits your application.

### Performance graph from page 98

Disc Cone Clutches

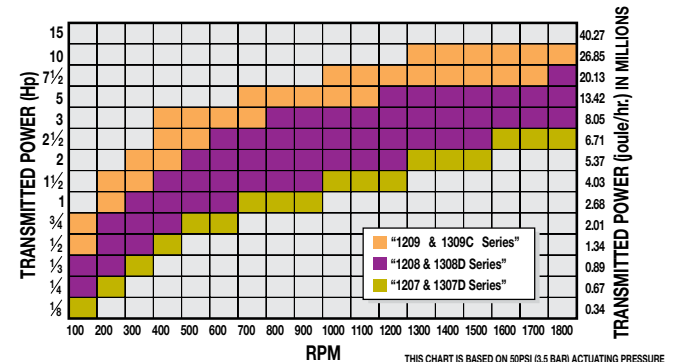

## SELECTION

repeated for reference:

### SELECT OPTIONS

A clutch must have a means to transmit power. This may be done with either sheaves or sprockets.

### Sprockets

Tolomatic offers several varieties of sprockets for Disc/Cone clutches. (See page 106 for models available.) Like sheave mounts, these sprockets are factory-mounted to the pilot and the pilots have bolt holes that can easily handle other sizes of sprockets.

### CONSIDER OPTIONAL CLUTCH/BRAKE

Some applications may require controlled deceleration as well as acceleration. Disc/Cone clutches are available with an 8", 10", 12" and 16" disc and either a Tolomatic P20DA or P220DA caliper disc brake. (See page 107 for models available.)

### CALCULATING HEAT DISSIPATION

Heat dissipation must also be considered in sizing a clutch. To find the amount of heat which an application will generate, which in turn must be dissipated, use the following formulae:

$$E = \frac{WK^2N^2}{5872} \text{ or } E = \frac{\pi TNt}{60}$$

Where: **E** = Kinetic Energy; ft-lbs

Then use:  $BTU/Start = \frac{E}{778}$

$BTU/Hour = (BTU/Start) \times (Cycle Rate/Hour)$

To determine thermal horsepower, use:

$$\text{Thermal Horsepower} = \frac{BTU/Hour}{2545}$$

### CALCULATING TORQUE

Begin the calculation with this basic formula:  $T = \frac{WK^2N}{308t}$

Where: **T** = Torque (in foot-pounds)

**N** = Speed (in RPM)

**W** = Weight of the Rotating Member (in pounds)

**K<sup>2</sup>** = Radius of Gyration (in feet)

**t** = Starting Time (in seconds)

The radius of gyration is the distance from the center of rotation at which the entire rotating mass could be concentrated and still be equivalent to the actual distributed mass (see diagrams, below).

For multiple shaft systems, use the following formula:

$$WK_e^2 = WK_s^2 + WK_1^2 \left[ \frac{N_1}{N_s} \right]^2 + \dots$$

Where: **WK<sub>e</sub><sup>2</sup>** = Equivalent of WK<sup>2</sup> of multiple shaft system

**WK<sub>s</sub><sup>2</sup>** = WK<sup>2</sup> of shaft on which clutch is mounted

**WK<sub>1</sub><sup>2</sup>** = WK<sup>2</sup> of second shaft assembly

**N<sub>s</sub>** = RPM of shaft on which clutch is mounted

**N<sub>1</sub>** = RPM of second shaft  $T = \frac{WK_e^2 N_s}{308t}$

The formula is modified to read:

### Solid Cylinder About its Own Axis

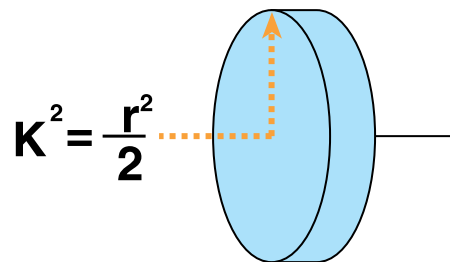

### Hollow Cylinder About its Own Axis

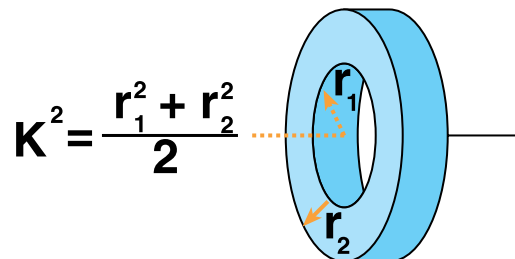

## GLOSSARY

### A

**AXIAL LOADING:** A load with a force directed along an axis, such as a shaft.

### B

**BACKING PLATE:** Steel plate on which brake linings are mounted.

**BLEEDING:** Method of purging air from a brake system's hydraulic lines and cylinders. Air is compressible and contaminates brake fluid. It is released via a "bleeder valve".

**BONDED LINING:** Brake lining (friction material) attached to the backing plate with adhesive.

**BRAKE BALANCE:** The ratio of braking force distributed between the front and rear wheels.

**BRAKE DISC (OR ROTOR):** The basis of a disc brake system: a round metal disc which rotates with the road wheel and, in order to generate braking power, is clamped by a caliper holding two friction linings (pads).

**BRAKE FADE:** Reduction (or complete loss) of braking performance, usually caused by too much heat in the system.

**BRAKE FEEL:** Sensation transmitted to the driver during a braking action via the brake pedal.

**BRAKE FLUID:** Liquid formulated specifically to be used in hydraulic brake systems.

**BRAKE HOSE:** Flexible rubber (or synthetic) hose used to join hydraulic brake components.

**BRAKE LINE:** Rigid tubing which links various hydraulic components in a brake system.

**BRAKE LINING:** Common name for Friction Material.

**BRAKE PAD:** The component in a disc brake system which is fitted with brake lining and clamped against the brake disc to cause friction.

**BUNA-N:** A widely used copolymer (artificial rubber) used for making seals. Buna-N seals should never be used with automotive brake fluid.

### C

**CALIPER:** A type of clamp which grips a disc rotor to create friction and thereby generate stopping power.

**CENTER OF GRAVITY:** (Center of Mass) The point at which the entire weight of a body may be considered as concentrated so that if supported at this point the body would remain in equilibrium in any position.

**COEFFICIENT OF FRICTION:** The measurement of friction of one object sliding across another. Symbolized by the Greek letter  $\mu$  (m) it is defined as the tangent of the angle of repose of a static body. The coefficient is expressed in decimal values (clean iron on clean iron is 1.0, while metal on solid rubber may range from 1.0 up to 4.0). When objects are wet, the coefficient of friction decreases.

**CROSS-DRILLED DISC:** Disc with friction surfaces which have been drilled with rows of holes to improve cooling, reduce weight and provide an escape route for dirt and gasses which can be wedged between the pads and disc. High-performance rotors can be both cross-drilled and slotted.

**CURVED VANE DISC:** Ventilated rotor in which the cooling channels (or vanes) have been curved to increase their ability to pump out hot air and cool the disc. Curved vane rotors are more efficient than conventional ventilated rotors and, as a side benefit, tend to be stronger.

### D

**DISC BRAKE:** The most popular and effective type of automotive brake. It uses a rotor (a round grey metal plate) which is squeezed by a caliper to create friction and thereby generate stopping power.

**DISC THICKNESS VARIATION:** A variation in thickness between two points on the friction surface of a disc rotor (usually caused by poor manufacture, poor machining or rubbing of the rotor against the caliper when the brakes are "off").

**DISCARD THICKNESS:** Alternative term for Minimum Thickness.

**DOUBLE-ACTING BRAKES:** Double-acting brakes apply pressure to pucks on each side of the disc. Both disc and brake may be fixed mounted.

**DRUM BRAKE:** A type of older - but still popular and effective - automotive brake in which a circular drum rotates around a set of brake shoes which are fixed to the hub and act on the drum by expanding.

### F

**FLAT BASE:** Mounting style for Float-A-Shaft standard series

**FLOATING BRACKET:** Method of mounting single acting caliper disc brake that allows the force of the brake to be applied to both sides of the disc.

**FOOT MOUNT:** Mounting style for Float-A-Shaft compact series.

**FRICTION MATERIAL:** Material which is pushed against a disc by a shoe or caliper to generate friction.

**FRICTION SURFACES:** Any of the surfaces designed to rub together in a brake system to create friction and therefore stopping power.

### G

**GLAZING:** The process whereby a brake lining or disc rotor becomes smooth and glossy due to excess heat.

### H

**HEAT DISSIPATION:** The process whereby braking components rid themselves of heat caused by friction. The heat in a disc system is mostly dissipated into the surrounding air. Dissipation can be accelerated by various forms of ventilation.

**HEAT SPOTS:** Shiny dark areas on a rotor caused by extreme heat.

**HERRINGBONE PATTERN:** Pattern found on the surface of a disc which has been poorly machined.

**HYDRAULIC SYSTEM:** The delivery system of a modern braking set-up. It uses fluid to transmit the force applied at the pedal to activate the disc calipers.

**HYGROSCOPIC:** A characteristic whereby something tends to absorb water. Brake fluid is hygroscopic.

### J

**JOURNAL BEARING:** A type of bearing material used in Float-A-Shafts for applications with lower torque requirements.

### K

**KEY:** A demountable machinery part, which, when assembled into a keyseat, provides a positive means for transmitting torque between two other machine parts.

**KEYWAY:** An axially-located groove in the length of a shaft along which a key might move.

### M

**MANUAL BRAKES:** Braking system which does not use power-assistance to magnify the pedal effort.

**MASTER CYLINDER:** The engine-room of a brake system, where the force applied at the pedal is converted into hydraulic pressure.

**MINIMUM THICKNESS:** The thickness at which a disc rotor must be discarded. Through wear and machining a disc rotor becomes thinner over time; as a result it becomes less able to dissipate heat and more prone to warping and other problems. The minimum thickness is usually determined by the vehicle manufacturer.

### MODIFIED STANDARD PRODUCTS:

Tolomatic can easily accommodate your special needs. Our standard products are often customized with extra mounting holes, different materials and other requests. This can often be done within our normal 5 day production time. We welcome modifications as well as completely new custom products.

### N

**NEEDLE BEARING:** A type of roller bearing where the journal turns on small-diameter, hardened needle-like rollers which roll easily in a metal race.

**NON-ASBESTOS LINING:** Friction material which uses no asbestos, thereby being easier on public health (breathing asbestos dust can cause the disease asbestosis).

### O

**ORIGINAL EQUIPMENT:** Industry term for a component supplied with a new vehicle or as an official replacement part. Known as OEM or "Original Equipment Manufacturer" parts, they are not necessarily produced by the vehicle-maker in question.

**OUT-OF-ROUND:** Effect where a disc is no longer true to its original shape, as a result of either warping, inconsistent wear or other damage. This can cause pulsing, grabbing, additional noise and lowered performance.

### P

**PARALLELISM:** A term which refers to the relationship between the two friction surfaces on a disc brake rotor.

**PROPORTIONING VALVE:** Hydraulic control designed to stop the rear wheels from locking up (rear wheels become "light" under heavy braking and therefore more likely to skid).

**PULLING:** Tendency of a vehicle to pull to one side under braking.

**PULSING:** Uneven or stutter-like force transmitted through the brake pedal during braking, usually caused by problems with disc rotors or linings.

### R

**RESERVOIR:** Chamber connected to the master cylinder (usually by hoses) and used for storing hydraulic fluid.

**ROLLER BEARING:** An anti-friction device consisting of a journal which rests on free-rolling, hardened cylinders in a race.

**ROTOR:** Alternative name for brake disc.

**RUN-OUT:** Rotors which are warped or out-of-true have excess "run-out", meaning the surface varies or wobbles as it rotates around a fixed point.

### S

**SINGLE-ACTING BRAKES:** Single-acting brakes have piston and puck on "live side" and a non-actuated puck on the "dead side". Since only one side applies force to the disc, a means to allow movement of the disc or caliper must be provided.

**SLOTTED DISC:** Type of disc brake rotor which has a series of slots or grooves across its friction surfaces. These are designed to improve the bite of the pads and break down the build-up of gas and dirt which can occur between pad and rotor. High-performance rotors can be both slotted and cross-drilled.

**SOLID ROTOR:** Disc rotor with solid metal between the two friction surfaces.

**SPONGY PEDAL:** Pedal which feels spring-like, perhaps due to the presence of air in the hydraulic system.

**SWEEP AREA:** Total friction area contacted by the pads during one revolution of the rotor.

### T

**TENSILE STRENGTH:** The greatest longitudinal stress a substance can bear without permanent deformation.

**T.I.R. (Total Indicated Reading):** An industry-accepted standard for measuring straightness and roundness.

**TOLERANCE:** A specified allowance for error from a desired or measured quantity.

**TORQUE:** A force that produces rotation. A turning or twisting force. (From the Latin torquere - to twist.)

### V

**VENTILATED ROTOR:** Disc rotor which has a series of fins (or cooling passages) between the two friction surfaces to aid in heat dissipation.

**VITON®:** A DuPont Chemical Co. trademark for a fluorocarbon rubber used in high temperature applications. At Tolomatic, Viton® is used for seals in high temperature situations and for brakes designed to be operated with non-flammable hydraulic fluids such as phosphate-ester.



# Engineering Resources

## CONVERSION TABLES

(TO CONVERT FROM A TO B, MULTIPLY BY ENTRY IN TABLE)

### Length

A \ B	in	ft	yd	mm	cm	m
in	1	0.0833	0.028	25.4	2.54	0.0254
ft	12	1	0.333	304.8	30.48	0.3048
yd	36	3	1	914.4	91.44	0.914
mm	0.03937	0.00328	0.00109	1	0.1	0.001
cm	0.3937	0.03281	0.0109	10	1	0.01
m	39.37	3.281	1.09	1,000	100	1

### Mass

A \ B	gm	kg	slug	lb(m)	oz(m)
gm	1	0.001	$6.852 \times 10^{-5}$	$2.205 \times 10^{-3}$	0.03527
kg	1,000	1	$6.852 \times 10^{-2}$	2.205	35.274
slug	14,590	14.59	1	32.2	514.72
lb(m)	453.6	0.45359	0.0311	1	16
oz(m)	28.35	0.02835	$1.94 \times 10^{-3}$	0.0625	1

### Pressure

A \ B	atm	bar	millibar	lbs/sqr ft (PSF)	lbs/sqr in (PSI)	N/sqr m (NSM)	N/sqr mm (NSMM)
atm	1	1.01325	1,013.25	2116.22	14.6454	101,325	0.101325
bar	0.986923	1	1,000	2088.54	14.5037	100,000	0.1
millibar	0.000987	0.001	1	2.08854	0.014504	100	0.0001
PSF	0.000473	0.000479	0.478803	1	0.006944	47.880	0.000048
PSI	0.068046	0.068948	68.94757	144	1	6,894.757	0.006895
NSM	0.00001	0.00001	0.01	0.020885	0.000145	1	0.000001
NSMM	98,692	10	10,000	20,885.43	145.0377	1,000,000	1

### Temperature

$^{\circ}\text{F} = (1.8 \times ^{\circ}\text{C}) + 32$
$^{\circ}\text{C} = .555 (^{\circ}\text{F} - 32)$

### Gravity

(Acceleration Constant)
$g = 386 \text{ in/s}^2 = 32.2 \text{ ft/s}^2 = 9.8 \text{ m/s}^2$

### Force

A \ B	lb(f)	N	dyne	oz(f)	kg(f)	gm(f)
lb(f)	1	4.4482	$4.448 \times 10^5$	16	0.45359	453.6
N	0.22481	1	100,000	3.5967	0.10197	101.97
dyne	$2.248 \times 10^{-6}$	0.00001	1	$3.59 \times 10^{-5}$	$1.02 \times 10^{-6}$	0.00102
oz(f)	0.0625	0.27801	$2.78 \times 10^4$	1	.02835	28.35
kg(f)	2.205	9.80665	980,665	35.274	1	1,000
gm(f)	$2.205 \times 10^{-3}$	0.0098	980.665	0.03527	0.001	1

### Power

A \ B	Watts	KW	HP (English)	HP(Metric)	ft-lb/s	in-lb/s
Watts	1	$1 \times 10^{-3}$	$1.34 \times 10^{-3}$	$1.36 \times 10^{-3}$	0.74	8.88
kw	1,000	1	1.34	1.36	738	8,880
hp(English)	746	0.746	1	1.01	550	6,600
hp(Metric)	736	0.736	0.986	1	543	6,516
ft-lb/s	1.36	$1.36 \times 10^{-3}$	$1.82 \times 10^{-3}$	$1.84 \times 10^{-3}$	1	12
in-lb/s	0.113	$1.13 \times 10^{-4}$	$1.52 \times 10^{-4}$	$1.53 \times 10^{-4}$	$8.3 \times 10^{-2}$	1

NOTE: lb(f) = 1 slug x 1 ft/s<sup>2</sup>      N = 1 kg x 1 m/s<sup>2</sup>      dyne = 1gm x 1 cm/s<sup>2</sup>

### Abbreviated Terms

atm = atmosphere (STD)	g = gravity	kg = kilogram	mm = millimeter	rad = radians
C = Celsius	gm = gram	kg(f) = kilogram force	m = meter	rpm = revs per minute
cm = centimeter	gm(f) = gram force	kw = Kilowatt	N = Newton	rps = revs per second
F = Fahrenheit	hp = horse power	lb(f) = pound force	oz(f) = ounce force	s = seconds
ft = foot	in = inch	lb(m) = pound mass	oz(m) = ounce mass	sq = square
		min = minute		

# Engineering Resources

## CONVERSION TABLES

(TO CONVERT FROM A TO B, MULTIPLY BY ENTRY IN TABLE)

### Torque

A \ B	dyne-cm	gm-cm	oz-in	kg-cm	lb-in	N-m	lb-ft	kg-m
dyne-cm	1	$1.019 \times 10^{-2}$	$1.416 \times 10^{-5}$	$1.0197 \times 10^{-6}$	$8.850 \times 10^{-7}$	$10^{-7}$	$7.375 \times 10^{-6}$	$1.019 \times 10^{-6}$
gm-cm	980.665	1	$1.388 \times 10^{-2}$	10-3	$8.679 \times 10^{-4}$	$9.806 \times 10^{-5}$	$7.233 \times 10^{-5}$	$10^{-5}$
oz-in	$7.061 \times 10^4$	72.007	1	$7.200 \times 10^{-2}$	$6.25 \times 10^{-2}$	$7.061 \times 10^{-3}$	$5.208 \times 10^{-3}$	$7.200 \times 10^{-4}$
kg-cm	$9.806 \times 10^5$	1,000	13.877	1	0.8679	$9.806 \times 10^{-2}$	$7.233 \times 10^{-2}$	$10^{-2}$
lb-in	$1.129 \times 10^6$	$1.152 \times 10^3$	16	1.152	1	0.112	$8.333 \times 10^{-2}$	$1.152 \times 10^{-2}$
N-m	$10^7$	$1.019 \times 10^4$	141.612	10.197	8.850	1	0.737	0.102
lb-ft	$1.355 \times 10^7$	$1.382 \times 10^4$	192	13.825	12	1.355	1	0.138
kg-m	$9.806 \times 10^7$	$10^5$	$1.388 \times 10^3$	100	86.796	9.806	7.233	1

### Inertia (Rotary) NOTE: Mass inertia = $\frac{\text{wt. inertia}}{g}$

A \ B	gm-cm <sup>2</sup>	oz-in <sup>2</sup>	gm-cm-s <sup>2</sup>	kg-cm <sup>2</sup>	lb-in <sup>2</sup>	oz-in-s <sup>2</sup>	lb-ft <sup>2</sup>	kg-cm-s <sup>2</sup>	lb-in-s <sup>2</sup>	lb-ft-s <sup>2</sup> or slug-ft-s <sup>2</sup>
gm-cm <sup>2</sup>	1	$5.46 \times 10^{-2}$	$1.01 \times 10^{-3}$	$10^{-3}$	$3.417 \times 10^{-4}$	$1.41 \times 10^{-5}$	$2.37 \times 10^{-6}$	$1.01 \times 10^{-4}$	$8.85 \times 10^{-7}$	$7.37 \times 10^{-4}$
oz-in <sup>2</sup>	182.9	1	0.186	0.182	0.0625	$2.59 \times 10^{-2}$	$4.34 \times 10^{-4}$	$1.86 \times 10^{-4}$	$1.61 \times 10^{-4}$	$1.34 \times 10^{-5}$
gm-cm-s <sup>2</sup>	980.6	5.36	1	0.9806	0.335	$1.38 \times 10^{-2}$	$2.32 \times 10^{-3}$	$10^{-3}$	$8.67 \times 10^{-4}$	$7.23 \times 10^{-5}$
kg-cm <sup>2</sup>	1,000	5.46	1.019	1	0.3417	$1.41 \times 10^{-2}$	$2.37 \times 10^{-3}$	$1.019 \times 10^{-3}$	$8.85 \times 10^{-4}$	$7.37 \times 10^{-5}$
lb-in <sup>2</sup>	$2.92 \times 10^3$	16	2.984	2.925	1	$4.14 \times 10^{-2}$	$6.94 \times 10^{-3}$	$2.96 \times 10^{-3}$	$2.59 \times 10^{-3}$	$2.15 \times 10^{-4}$
oz-in-s <sup>2</sup>	$7.06 \times 10^4$	386.08	72.0	70.615	24.13	1	0.1675	$7.20 \times 10^{-2}$	$6.25 \times 10^{-2}$	$5.20 \times 10^{-3}$
lb-ft <sup>2</sup>	$4.21 \times 10^5$	2,304	429.71	421.40	144	5.967	1	0.4297	0.3729	$3.10 \times 10^{-2}$
kg-cm-s <sup>2</sup>	$9.8 \times 10^5$	$5.36 \times 10^3$	1,000	980.66	335.1	13.887	2.327	1	0.8679	$7.23 \times 10^{-2}$
lb-in-s <sup>2</sup>	$1.129 \times 10^4$	$6.177 \times 10^3$	$1.152 \times 10^3$	$1.129 \times 10^3$	386.08	16	2.681	1.152	1	$8.33 \times 10^{-2}$
lb-ft-s <sup>2</sup>	$1.355 \times 10^7$	$7.41 \times 10^4$	$1.38 \times 10^4$	$1.35 \times 10^4$	$4.63 \times 10^3$	192	32.17	13.825	12	1

### Angular Velocity

A \ B	deg/s	rad/s	rpm	rps
deg/s	1	$1.75 \times 10^{-2}$	0.167	$2.78 \times 10^{-3}$
rad/s	57.3	1	9.55	0.159
rpm	6	0.105	1	$1.67 \times 10^{-2}$
rps	360	6.28	60	1

### Linear Velocity

A \ B	in/min	ft/min	in/sec	ft/sec	mm/sec	m/sec
in/min	1	0.0833	0.0167	$1.39 \times 10^{-3}$	0.42	$4.2 \times 10^{-4}$
ft/min	12	1	.2	0.0167	5.08	$5.08 \times 10^{-3}$
in/sec	60	5	1	0.083	25.4	0.0254
ft/sec	720	60	12	1	304.8	0.3048
cm/sec	23.62	1.97	0.3937	0.0328	10	0.01
m	2,362.2	196.9	39.37	3.281	1,000	1

# TERMS / CONDITIONS OF SALE

**1. ORDER ACCEPTANCE.** All orders or services are subject to acceptance in Minnesota by the written approval of an authorized official of Tolomatic, Inc.. Any such order shall be subject to these Terms and Conditions of Sale, and acceptance shall be conditioned on Purchaser's assent to such conditions. Purchaser's assent shall be deemed given unless Purchaser shall expressly notify Tolomatic, Inc. in writing to the contrary within five (5) days after receipt of acknowledgment to confirmation of an order.

**2. CANCELLATION AND CHANGES.** No order accepted by Tolomatic, Inc. may be modified in any manner by Purchaser unless agreed to in writing, by an authorized official of Tolomatic, Inc.. Order cancellations, including reductions to order quantities, and changes shall be governed by the following:

- a. Any standard product order scheduled for shipment within five (5) working days of purchaser's request to cancel or modify will be shipped as previously acknowledged and purchaser agrees to accept shipment and payment responsibility, in full, at the price agreed upon.
- b. "Customer Special" orders scheduled for shipment within twenty (20) working days of purchaser's request to cancel or modify will be shipped as previously acknowledged and purchaser agrees to accept shipment and payment responsibility, in full, at the price agreed upon.
- c. All work in connection with "Customer Special" orders, not covered under Paragraph b, will be stopped immediately upon notification, and purchaser agrees to reimburse Tolomatic, Inc. for all work-in-process and any materials or supplies used, or for which commitments have been made by Tolomatic, Inc. in connection therewith.

**3. QUOTATIONS AND PRICES.** Written quotations automatically expire 30 calendar days from the date issued unless terminated sooner by written notice. (Verbal quotations expire, unless accepted in writing, the same day.)

All published prices and discounts are subject to change without notice. In the event of a net price change, the price of

product(s) on order will be the price in effect on the date of order acknowledgment. Any addition to an outstanding order will be accepted at prices in effect when the addition is made.

**4. MINIMUM BILLING.** Orders amounting to less than \$35.00 net will be billed at \$35.00

**5. TAXES.** Any Manufacturer's Tax, Retailers Occupation Tax, Use Tax, Sales Tax, Excise Tax, Duty, Customer, Inspection or Testing Fee, or any other tax, fee or charge of any nature whatsoever, imposed by any government authority, on or measured by any transactions between Tolomatic, Inc. and Purchaser shall be paid by the Purchaser in addition to the prices quoted or involved. In the event Tolomatic, Inc. shall be required to pay any such tax, fee or charge, Purchaser shall reimburse therefore.

**6. TERMS OF PAYMENT.** Net invoice amount is due within 30 days from date of invoice subject to credit approval. A 2% per month service charge shall apply to all invoices not paid within 30 days. All clerical errors are subject to correction. Any invoice in not paid within 60 days will subject that account to an immediate shipping hold.

**7. F.O.B. POINT.** All sales are F.O.B. Tolomatic, Inc.'s facility in Hamel, Minnesota, unless quoted otherwise.

**8. DELIVERY.** Delivery of product(s) by Tolomatic, Inc. to a carrier shall constitute delivery to Purchaser, and regardless of freight payment, title and all risk or loss or damage in transit shall pass to Purchaser at that time.

Should shipment be held beyond scheduled date, upon request of Purchaser, product will be billed and Purchaser agrees to accept any charges for warehousing, trucking and other expenses as may be incident to such delay.

Great care is taken by Tolomatic, Inc. in crating its product. Tolomatic, Inc. cannot be held responsible for breakage after having received "In Good Order" receipts from the transporting carrier. All claims for loss and damage must be made by Purchaser to the carrier within 14 days from receipt of goods. Tolomatic, Inc. will assist insofar as practical in securing satisfactory adjustment of such claims wherever possible.

Claims for shortages or other errors must be made, in writing, within ten (10) days to Tolomatic, Inc. and any additional expense of the method or route of shipment specified by Purchaser shall be borne by the Purchaser.

**9. SHIPPING SCHEDULES.** All quoted shipping schedules are approximate and will depend upon prompt receipt from Purchaser of confirming copy of Purchase Order. Dimensional drawings and specifications submitted by Tolomatic, Inc. to Purchaser for approval must be returned to Tolomatic, Inc. within 10 working days, with approval granted, and any exceptions noted, in order to avoid delay in manufacturing schedules.

Orders which include penalty clauses for failure to meet shipping schedules will not be acceptable, except in those cases specifically approved in writing by the General Manager of Tolomatic, Inc..

Tolomatic, Inc. shall not be liable for damage as a result of any delay due to any cause beyond Tolomatic, Inc.'s reasonable control, including, without limitation, an Act of Nature; act of Purchaser; embargo, or other government act, regulation or request; fire; accident; strike; slow down; war; riot; flood; delay in transportation; and inability to obtain necessary labor, materials or manufacturing facilities. In the event of any such delay, the date of delivery shall be extended for a period equal to the time loss by reason of the delay. The acceptance of the product when delivered shall constitute a waiver of all claims for damages caused by any such delays.

**10. RETURN OF PRODUCT.** No product may be returned without first obtaining a Return Goods Authorization form and confirming memorandum from Tolomatic, Inc.. Product, if accepted for credit, shall be subject to a minimum service charge of 35% of the invoice price and all transportation charges shall be prepaid by the Purchaser; however, assembled products classified as "special," such as Cable Cylinders and other products which have been modified or built as "Customer Specials," are not returnable to Tolomatic, Inc..

**11. WARRANTY.** Tolomatic, Inc., WARRANTS PRODUCT MANUFACTURED BY IT TO BE FREE FROM DEFECTS IN MATERIAL AND WORKMANSHIP FOR A PERIOD OF

ONE YEAR FROM DATE OF SHIPMENT BY Tolomatic, Inc.. IF WITHIN SUCH PERIOD ANY SUCH PRODUCT SHALL BE PROVED TO Tolomatic, Inc.'s SATISFACTION TO BE SO DEFECTIVE, SUCH PRODUCT SHALL EITHER BE REPAIRED OR REPLACED AT Tolomatic, Inc.'s OPTION.

THIS WARRANTY SHALL NOT APPLY:

a. TO PRODUCT NOT MANUFACTURED BY Tolomatic, Inc. WITH RESPECT TO PRODUCT NOT MANUFACTURED BY Tolomatic, Inc.. THE WARRANTY OBLIGATIONS OF Tolomatic, Inc. SHALL IN ALL RESPECTS CONFORM AND BE LIMITED TO THE WARRANTY ACTUALLY EXTENDED TO Tolomatic, Inc. BY ITS SUPPLIER.

b. TO PRODUCT WHICH SHALL HAVE BEEN REPAIRED OR ALTERED BY PARTIES OTHER THAN Tolomatic, Inc. SO AS, IN Tolomatic, Inc.'s JUDGMENT, TO AFFECT THE SAME ADVERSELY, OR

c. TO PRODUCT WHICH SHALL HAVE BEEN SUBJECT TO NEGLIGENCE, ACCIDENT, OR DAMAGE BY CIRCUMSTANCES BEYOND THE CONTROL OF Tolomatic, Inc. OR TO IMPROPER OPERATION MAINTENANCE OR STORAGE, OR TO OTHER THAN NORMAL USE AND SERVICE.

THE FOREGOING WARRANTIES ARE EXCLUSIVE AND IN LIEU OF ALL OTHER EXPRESS AND IMPLIED WARRANTIES WHATSOEVER, INCLUDING BUT NOT LIMITED TO IMPLIED WARRANTIES OF MERCHANTABILITY AND FITNESS FOR A PARTICULAR PURPOSE, Tolomatic, Inc. SHALL NOT BE SUBJECT TO ANY OTHER OBLIGATIONS OR LIABILITIES WHATSOEVER WITH RESPECT TO PRODUCT MANUFACTURED OR SUPPLIED BY Tolomatic, Inc. OR SERVICE RENDERED BY IT.

**12. CONSEQUENTIAL DAMAGE.** Tolomatic, Inc., shall not, under any circumstances be liable for consequential damages.

**13. SERVICE CHARGES.** Should the Purchaser request the service of any erector, demonstrator or service man (except as specifically provided for and included in the price of the product) such service will be rendered at the rate outlined in the schedule of field service charges in effect at the date of request.

# THE TOLOMATIC DIFFERENCE

What you expect from the industry leader:



## EXCELLENT CUSTOMER SERVICE & TECHNICAL SUPPORT

Our people make the difference! Expect prompt, courteous replies to all of your application and product questions.



## INDUSTRY LEADING DELIVERIES

Standard catalog products are built to order and ready-to-ship in 5 days or less. Modified and custom products ship weeks ahead of the competition.

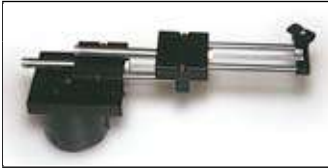

## INNOVATIVE PRODUCTS

From standard catalog products... to modified products... to completely unique custom products, Tolomatic designs and builds the best solutions for your challenging applications.



## ONLINE SIZING & SELECTION SOFTWARE

Online sizing that is easy to use, accurate and always up-to-date. Input your application data and the software will determine a Tolomatic electric actuator to meet your requirements.



## 3D MODELS & 2D DRAWINGS AVAILABLE ON THE WEB

Easy to access CAD files are available in many popular formats.

## ALSO CONSIDER THESE OTHER TOLOMATIC PRODUCTS:

### PNEUMATIC PRODUCTS



*RODLESS CYLINDERS: Band Cylinders, Cable Cylinders, MAGNETICALLY COUPLED CYLINDERS/SLIDES; GUIDED ROD CYLINDER SLIDES*

"FOLDOUT" BROCHURE #9900-9075  
PRODUCTS BROCHURE #9900-4028

### ELECTRIC PRODUCTS



*ROD & GUIDED ROD STYLE ACTUATORS, HIGH THRUST ACTUATORS, SCREW & BELT DRIVE RODLESS ACTUATORS, MOTORS, DRIVES AND CONTROLLERS*

"FOLDOUT" BROCHURE #9900-9074  
PRODUCTS BROCHURE #9900-4016

### POWER TRANSMISSION PRODUCTS



*GEARBOXES: Float-A-Shaft®, Slide-Rite®; DISC CONE CLUTCH; CALIPER DISC BRAKES*

"FOLDOUT" BROCHURE #9900-9076  
PRODUCTS BROCHURE #9900-4029



3800 County Road 116 • Hamel, MN 55340 U.S.A.  
Phone: (763) 478-8000 • Fax: (763) 478-8080

Toll-Free: **1-800-328-2174**

Email: [help@tolomatic.com](mailto:help@tolomatic.com) • <http://www.tolomatic.com>

All brand and product names are trademarks or registered trademarks of their respective owners. Information in this document is believed accurate at time of printing. However, Tolomatic assumes no responsibility for its use or for any errors that may appear in this document. Tolomatic reserves the right to change the design or operation of the equipment described herein and any associated motion products without notice. Information in this document is subject to change without notice.

Visit [www.tolomatic.com](http://www.tolomatic.com) for the most up-to-date technical information

